

CIVA

FAI

AEROBATICS
COMMISSION

EAAC 2019 1st - 11th Aug

Form B

Pilot ID

CIVA Advanced Unknown2

Flight #

FIN

A

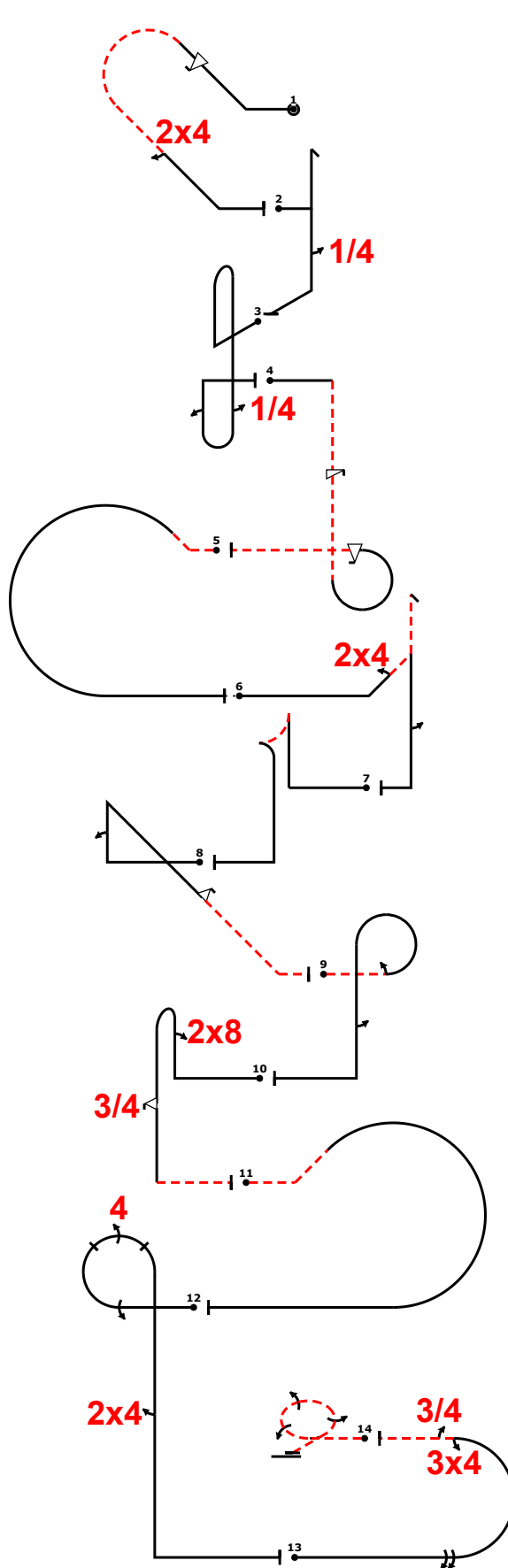

Power		
Fig	Aresti	K
1	8.4.18.1	14
	9.9.2.4	13
	9.4.4.2	5
2	5.2.1.1	17
	9.1.5.1	2
3	8.8.2.1	19
	9.1.5.1	2
	9.1.1.2	8
4	8.6.3.3	13
	9.11.1.4	5
	9.9.3.4	11
5	8.5.1.2	10
	8.5.1.2	6
6	5.3.2.1	24
	9.4.2.2	7
	9.1.5.2	4
7	6.2.2.1	15
	6.2.2.1	15
	6.2.2.1	15
8	1.2.8.1	16
	9.1.1.2	8
	9.9.4.2	11
9	8.6.7.2	12
	9.1.3.2	4
	9.1.5.2	4
10	8.4.2.1	14
	9.8.1.1	7
	9.9.5.3	11
11	8.5.1.2	10
	8.5.1.2	6
12	8.6.5.1	11
	9.1.3.4	8
	9.4.3.4	11
13	7.2.1.1	6
	9.1.3.8	12
	9.1.3.3	6
14	2.3.4.4	34
	2.3.4.4	34
Total K = 322		

 Pilot
 A/C

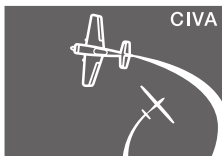

CIVA

FAI

AEROBATICS COMMISSION

EAAC2019 1st - 11th Aug

Form B

Pilot ID

CIVA Advanced Unknown2

Flight #

FIN

B

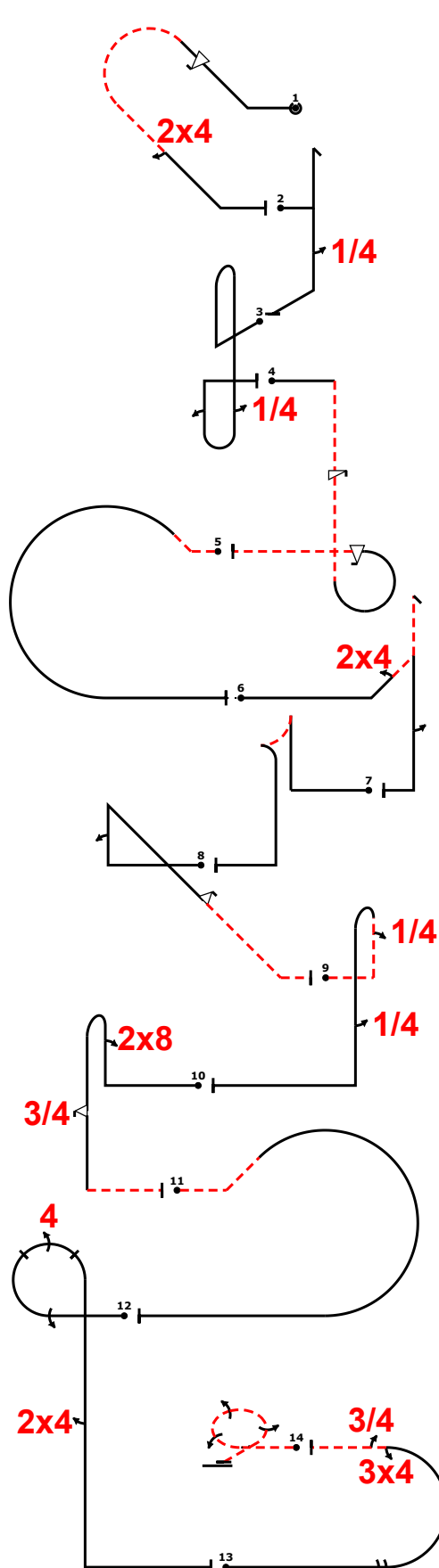

wind/vent

Power		
Fig	Aresti	K
1	8.4.18.1	14
	9.9.2.4	13
	9.4.4.2	5
2	5.2.1.1	17
	9.1.5.1	2
3	8.8.2.1	19
	9.1.5.1	2
	9.1.1.2	8
4	8.6.3.3	13
	9.11.1.4	5
	9.9.3.4	11
5	8.5.1.2	10
	8.5.1.2	6
6	5.3.2.1	24
	9.4.2.2	7
	9.1.5.2	4
7	6.2.2.1	15
	6.2.2.1	15
8	1.2.8.1	16
	9.1.1.2	8
	9.9.4.2	11
9	8.4.4.2	14
	9.1.1.1	6
	9.1.5.1	2
10	8.4.2.1	14
	9.8.1.1	7
	9.9.5.3	11
11	8.5.1.2	10
	8.5.1.2	6
12	8.6.5.1	11
	9.1.3.4	8
	9.4.3.4	11
13	7.2.1.1	6
	9.1.3.8	12
	9.4.3.3	8
14	9.1.3.3	6
	2.3.4.4	34
Total K = 322		

 Pilot
 A/C

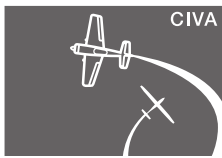

CIVA

FAI

AEROBATICS COMMISSION

EAAC 2019 1st - 11th Aug

Form B

Pilot ID

CIVA Advanced Unknown2

Flight #

FRA

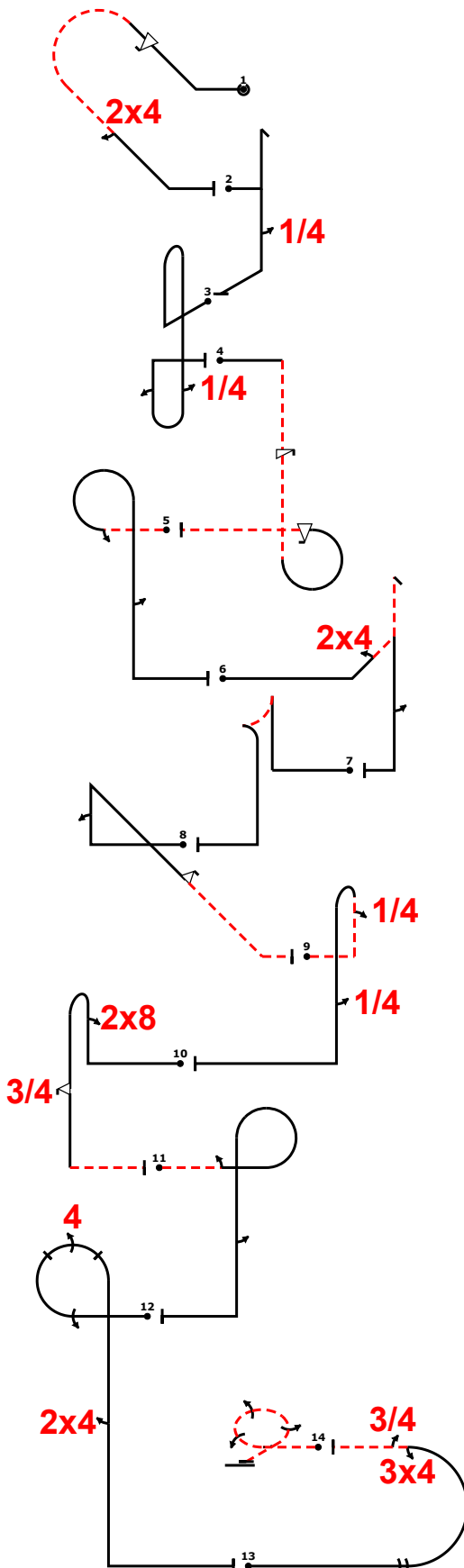

Power		
Fig	Aresti	K
1	8.4.18.1	14
	9.9.2.4	13
	9.4.4.2	5
2	5.2.1.1	17
	E 9.1.5.1	2
3	8.8.2.1	19
	9.1.5.1	2
	9.1.1.2	8
4	8.6.3.3	13
	9.1.1.4	5
	9.9.3.4	11
5	8.6.7.2	12
	9.1.3.2	4
	9.1.5.2	4
6	5.3.2.1	24
	9.4.2.2	7
	9.1.5.2	4
7	6.2.2.1	15
8	1.2.8.1	16
	9.1.1.2	8
	9.9.4.2	11
9	8.4.4.2	14
	9.1.1.1	6
	9.1.5.1	2
10	8.4.2.1	14
	9.8.1.1	7
	9.9.5.3	11
11	8.6.7.2	12
	9.1.3.2	4
	9.1.5.2	4
12	8.6.5.1	11
	9.1.3.4	8
	9.4.3.4	11
13	7.2.1.1	6
	9.1.3.8	12
	9.4.3.3	8
14	9.1.3.3	6
	2.3.4.4	34
Total K = 322		

C

 Pilot
 A/C



EAAC 2019 1st - 11th Aug		Form B
Pilot ID	CIVA Advanced Unknown2	Flight #

FAI

AEROBATICS COMMISSION

FRA

D

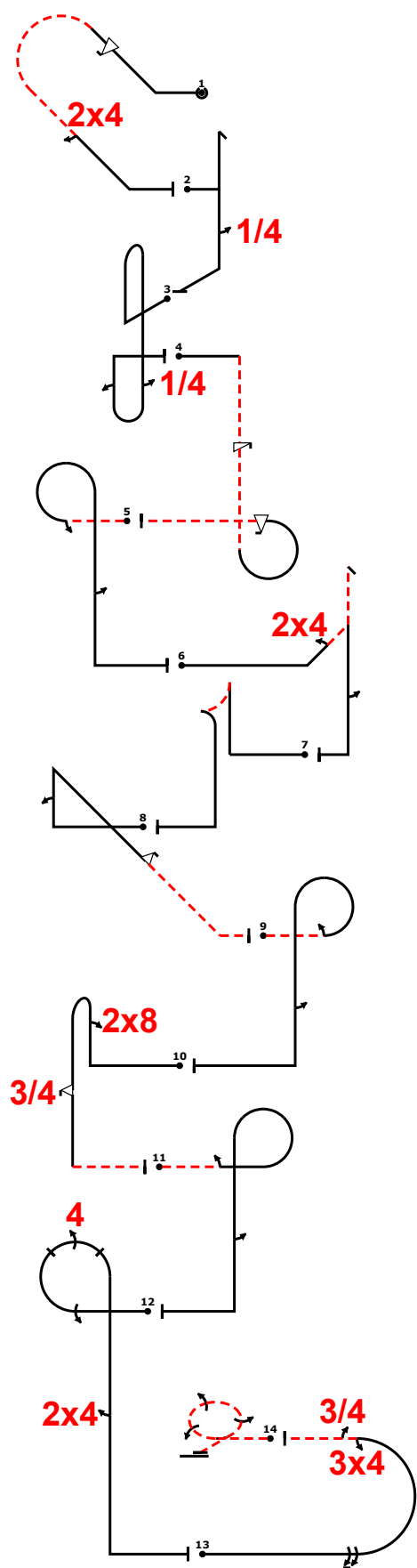
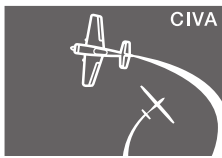

Fig	Aresti	K
1	8.4.18.1 9.9.2.4 9.4.4.2	14 13 5
2	5.2.1.1 6.9.1.5.1	17 2
3	8.8.2.1 9.1.5.1 9.1.1.2	19 2 6
4	8.6.3.3 9.1.1.4 9.9.3.4	13 5 29
5	8.6.7.2 9.1.3.2 9.1.5.2	12 4 6
6	5.3.2.1 9.4.2.2 9.1.5.2	24 7 4
7	6.2.2.1	15
8	1.2.8.1 9.1.1.2 9.9.4.2	16 8 11
9	8.6.7.2 9.1.3.2 9.1.5.2	12 4 6
10	8.4.2.1 9.8.1.1 9.9.5.3	14 7 11
11	8.6.7.2 9.1.3.2 9.1.5.2	12 4 6
12	8.6.5.1 9.1.3.4 9.4.3.4 9.4.5.2	11 8 11 5
13	7.2.1.1 9.1.3.8 9.4.3.3 9.1.3.3	6 12 8 6
14	2.3.4.4	34
Total K = 322		

Check: 4-8-2019 15:41 OpenAero 2019.2.3 2019 civa advanced programme3 Sequence is correct

Pilot
A/C



FAI
AEROBATICS
COMMISSION

EAAC 2019 1st - 11th Aug

Form B

Pilot ID

CIVA Advanced Unknown2

Flight #

GER

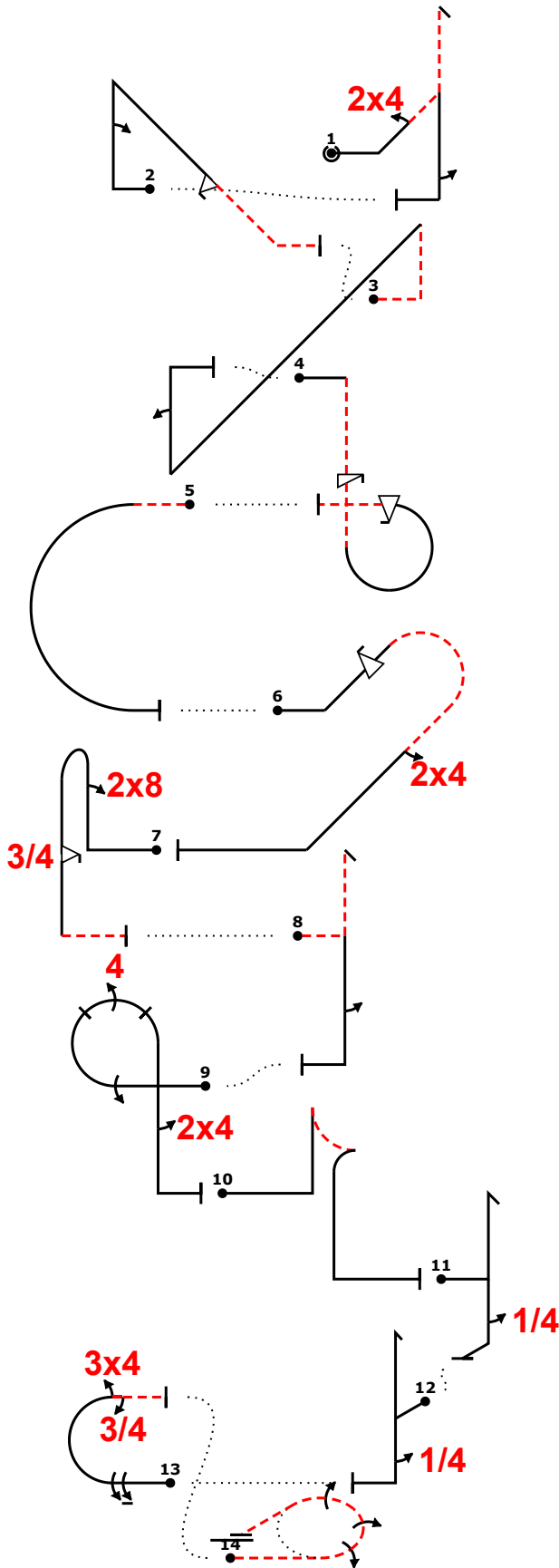
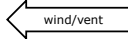

Power			
Fig	Aresti	K	
1 G	5.3.2.1	24	35
	9.4.2.2	7	
	9.1.5.2	4	
2 D	1.2.8.1	16	35
	9.1.1.2	8	
	9.9.4.2	11	
3 Add.	1.3.10.2	24	6
	9.1.1.2	8	
4 A	8.6.3.3	13	29
	9.11.1.4	5	
	9.9.3.4	11	
5 Add.	7.2.1.4	6	6
6 I	8.4.18.1	14	32
	9.9.2.4	13	
	9.4.4.2	5	
7 C	8.4.2.1	14	32
	9.8.1.1	7	
	9.9.5.3	11	
8 Add.	5.2.1.4	22	6
	9.1.5.2	4	
9 B	8.6.5.1	11	35
	9.1.3.4	8	
	9.4.3.4	11	
	9.4.5.2	5	
10 H	6.2.2.1	15	15
11 E	5.2.1.1	17	19
	9.1.5.1	2	
12 Add.	5.2.1.1	17	6
	9.1.5.1	2	
13 F	7.2.1.1	6	32
	9.1.3.8	12	
	9.4.3.3	8	
	9.1.3.3	6	
14 J	2.3.4.4	34	34
Total K = 322			

E

Pilot
A/C

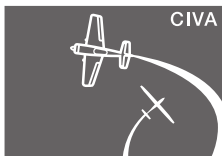

EAAC 2019 1st - 11th Aug		Form B
Pilot ID	CIVA Advanced Unknown2	
	Flight #	

FAI AEROBATICS COMMISSION

RUS

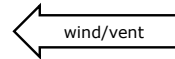

F

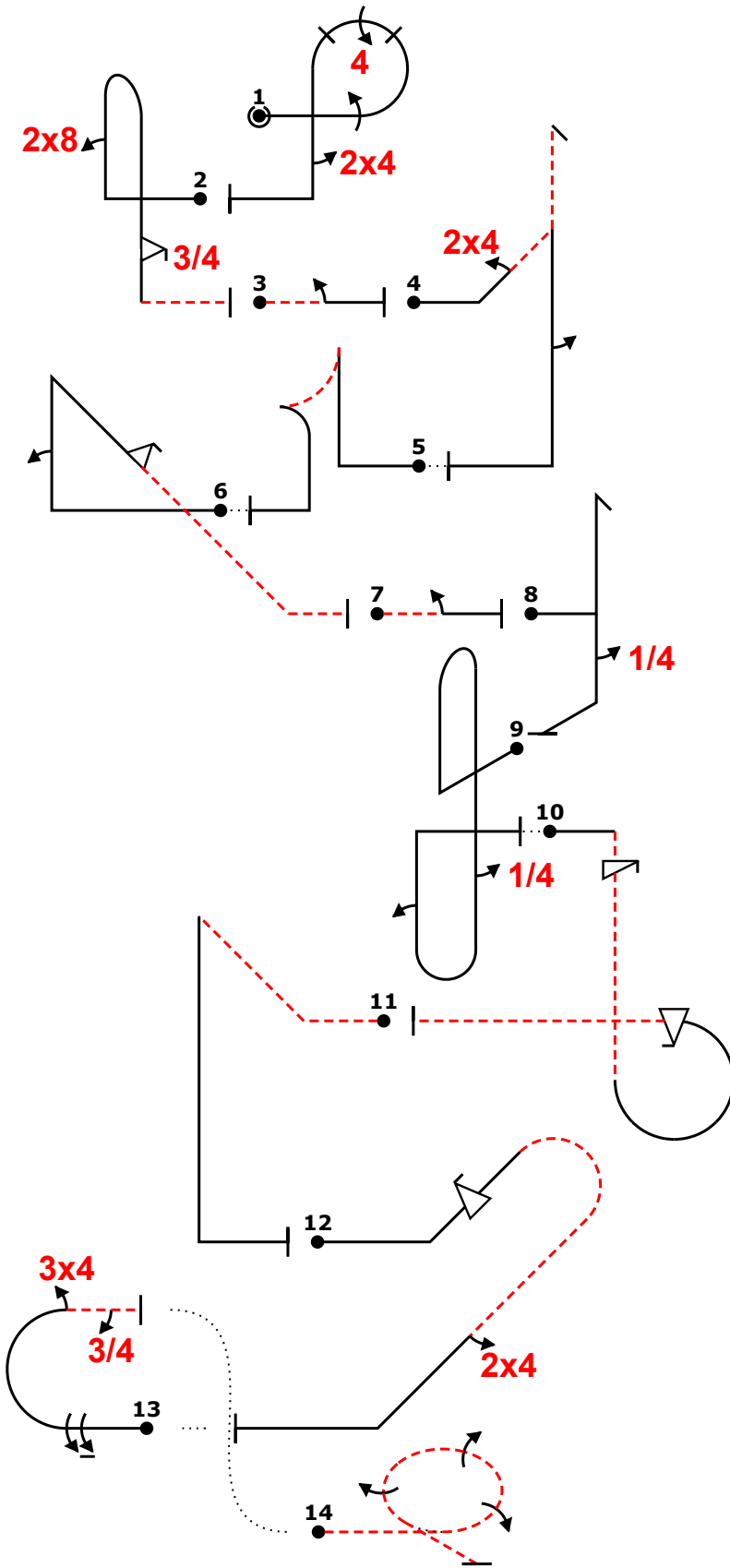

Power			
Fig	Aresti	K	
1 B	8.6.5.1	11	35
	9.1.3.4	8	
	9.4.3.4	11	
	9.4.5.2	5	
2 C	8.4.2.1	14	32
	9.8.1.1	7	
	9.9.5.3	11	
3 Add.	1.1.1.4	2	6
	9.1.3.2	4	
4 G	5.3.2.1	24	35
	9.4.2.2	7	
	9.1.5.2	4	
5 H	6.2.2.1	15	15
6 D	1.2.8.1	16	35
	9.1.1.2	8	
	9.9.4.2	11	
7 Add.	1.1.1.4	2	6
	9.1.3.2	4	
8 E	5.2.1.1	17	19
	9.1.5.1	2	
9 Add.	8.8.2.1	19	6
	9.1.5.1	2	
	9.1.1.2	8	
10 A	8.6.3.3	13	29
	9.11.1.4	5	
	9.9.3.4	11	
11 Add.	1.2.2.2	13	6
12 I	8.4.18.1	14	32
	9.9.2.4	13	
	9.4.4.2	5	
13 F	7.2.1.1	6	32
	9.1.3.8	12	
	9.4.3.3	8	
	9.1.3.3	6	
14 J	2.3.4.4	34	34
Total K = 322			

 Pilot
 A/C

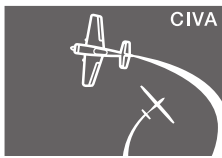

FAI
AEROBATICS
COMMISSION

EAAC 2019 1st - 11th Aug

Form B

Pilot ID

CIVA Advanced Unknown2

Flight #

RUS

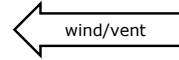

G

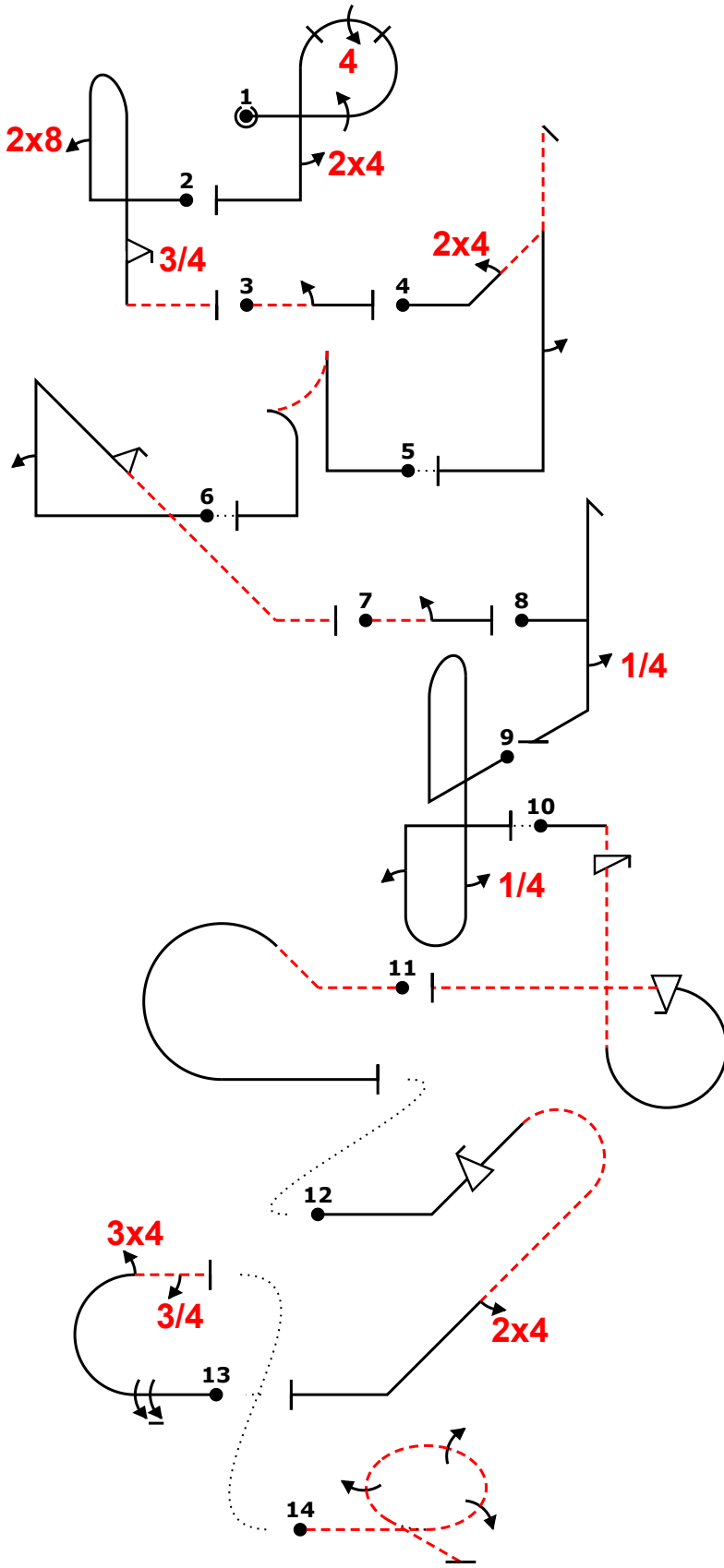

Power			
Fig	Aresti	K	
1 B	8.6.5.1	11	35
	9.1.3.4	8	
	9.4.3.4	11	
	9.4.5.2	5	
2 C	8.4.2.1	14	32
	9.8.1.1	7	
	9.9.5.3	11	
3 Add.	1.1.1.4	2	6
	9.1.3.2	4	
4 G	5.3.2.1	24	35
	9.4.2.2	7	
	9.1.5.2	4	
5 H	6.2.2.1	15	15
6 D	1.2.8.1	16	35
	9.1.1.2	8	
	9.9.4.2	11	
7 Add.	1.1.1.4	2	6
	9.1.3.2	4	
8 E	5.2.1.1	17	19
	9.1.5.1	2	
9 Add.	8.8.2.1	19	6
	9.1.5.1	2	
	9.1.1.2	8	
10 A	8.6.3.3	13	29
	9.11.1.4	5	
	9.9.3.4	11	
11 Add.	8.5.1.2	10	6
12 I	8.4.18.1	14	32
	9.9.2.4	13	
	9.4.4.2	5	
13 F	7.2.1.1	6	32
	9.1.3.8	12	
	9.4.3.3	8	
	9.1.3.3	6	
14 J	2.3.4.4	34	34
Total K = 322			

Pilot

A/C

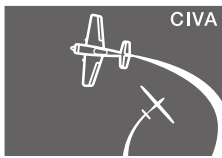

CIVA

FAI

AEROBATICS
COMMISSION

EAAC 2019 1st - 11th Aug

Form B

Pilot ID

CIVA Advanced Unknown2

Flight #

USA

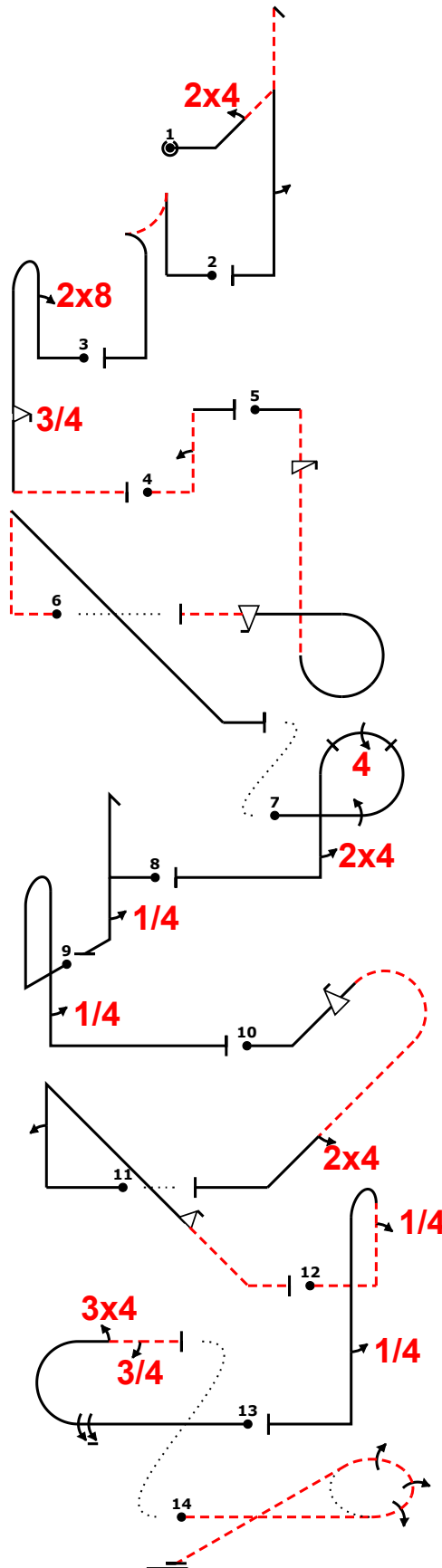
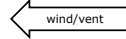

Power			
Fig	Aresti	K	
1 G	5.3.2.1	24	35
	9.4.2.2	7	
	9.1.5.2	4	
2 H	6.2.2.1	15	15
3 C	8.4.2.1	14	32
	9.8.1.1	7	
	9.9.5.3	11	
4 Add.	1.1.7.2	12	6
	9.1.1.2	8	
5 A	8.6.3.3	13	29
	9.11.1.4	5	
	9.9.3.4	11	
6 Add.	1.2.5.2	16	6
7 B	8.6.5.1	11	35
	9.1.3.4	8	
	9.4.3.4	11	
	9.4.5.2	5	
8 E	5.2.1.1	17	19
	9.1.5.1	2	
9 Add.	8.4.1.1	13	6
	9.1.5.1	2	
10 I	8.4.18.1	14	32
	9.9.2.4	13	
	9.4.4.2	5	
11 D	1.2.8.1	16	35
	9.1.1.2	8	
	9.9.4.2	11	
12 Add.	8.4.4.2	14	6
	9.1.1.1	6	
	9.1.5.1	2	
13 F	7.2.1.1	6	32
	9.1.3.8	12	
	9.4.3.3	8	
	9.1.3.3	6	
14 J	2.3.4.4	34	34
Total K = 322			

H

Pilot
A/C

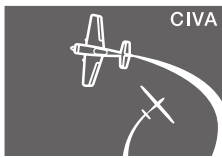

CIVA

FAI

AEROBATICS
COMMISSION

EAAC 2019 1st - 11th Aug

Form B

Pilot ID

CIVA Advanced Unknown2

Flight #

USA

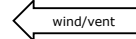

I

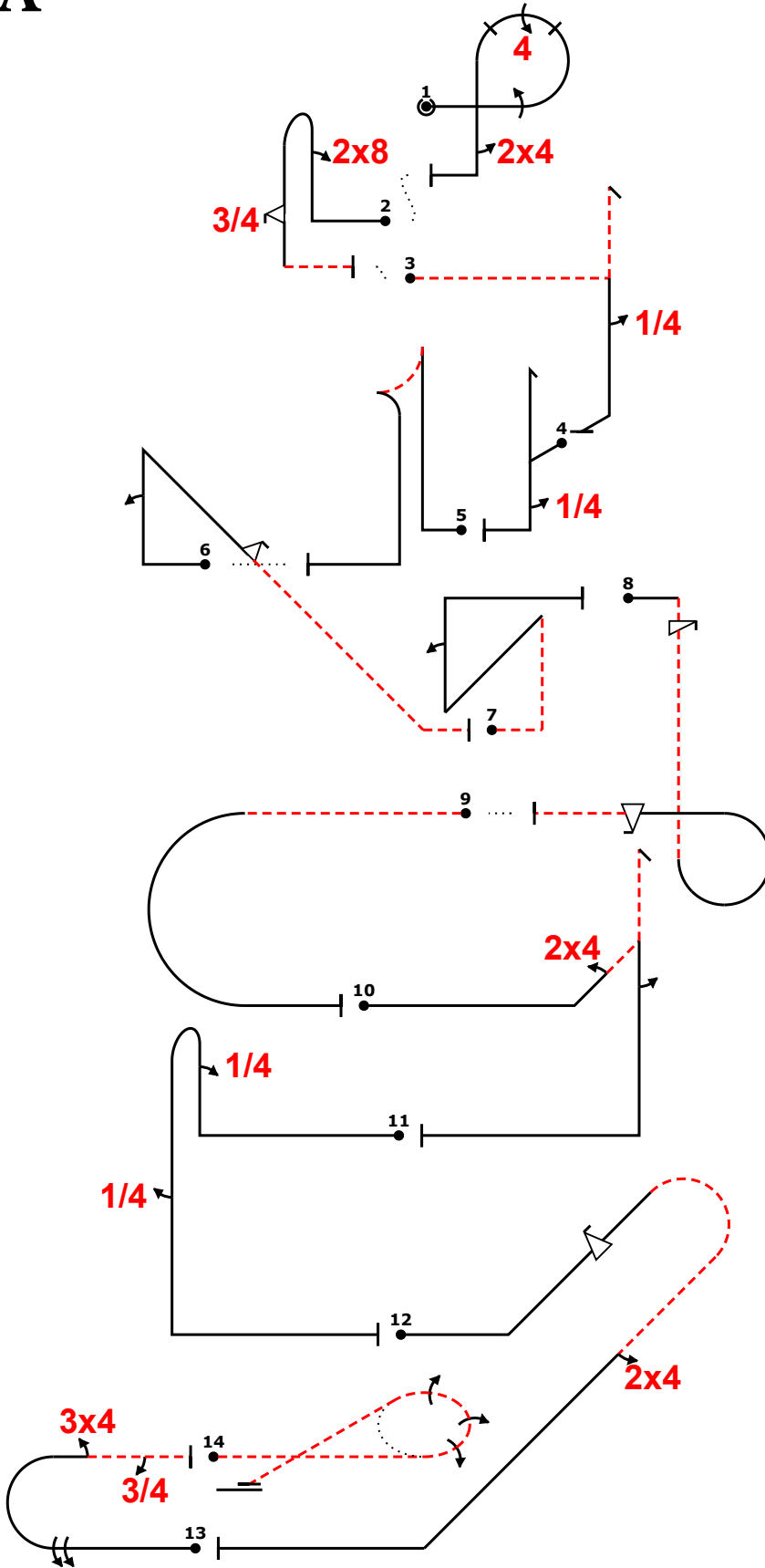

Power			
Fig	Aresti	K	
1 B	8.6.5.1	11	35
	9.1.3.4	8	
	9.4.3.4	11	
2 C	8.4.2.1	14	32
	9.8.1.1	7	
	9.9.5.3	11	
3 Add.	5.2.1.4	22	6
	9.1.5.1	2	
4 E	5.2.1.1	17	19
	9.1.5.1	2	
5 H	6.2.2.1	15	15
6 D	1.2.8.1	16	35
	9.1.1.2	8	
	9.9.4.2	11	
7 Add.	1.3.10.2	24	6
	9.1.1.2	8	
8 A	8.6.3.3	13	29
	9.1.1.4	5	
	9.9.3.4	11	
9 Add.	7.2.1.4	6	6
10 G	5.3.2.1	24	35
	9.4.2.2	7	
	9.1.5.2	4	
11 Add.	8.4.1.1	13	6
	9.1.1.1	6	
	9.1.5.1	2	
12 I	8.4.18.1	14	32
	9.9.2.4	13	
	9.4.4.2	5	
13 F	7.2.1.1	6	32
	9.1.3.8	12	
	9.4.3.3	8	
14 J	9.1.3.3	6	34
	2.3.4.4	34	
Total K = 322			

Pilot
A/C



EAAC 2019 1st - 11th Aug		Form B
Pilot ID	CIVA Advanced Unknown2	Flight #

ROU

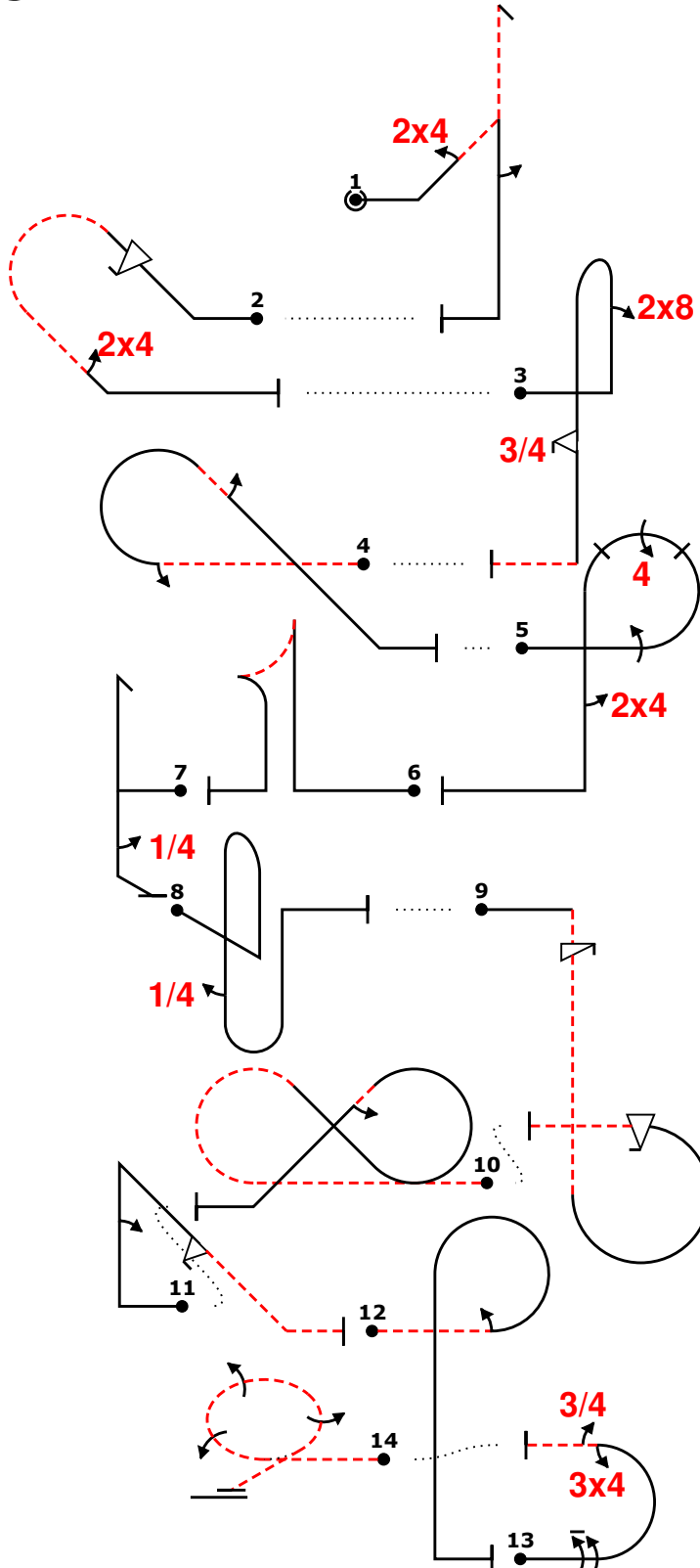
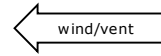

Power			
Fig	Aresti	K	
1 G	5.3.2.1	24	35
	9.4.2.2	7	
	9.1.5.2	4	
2 I	8.4.18.1	14	32
	9.9.2.4	13	
	9.4.4.2	5	
3 C	8.4.2.1	14	32
	9.8.1.1	7	
	9.9.5.3	11	
4 Add.	8.5.8.2	11	6
	9.1.3.2	4	
	9.1.4.2	4	
5 B	8.6.5.1	11	35
	9.1.3.4	8	
	9.4.3.4	11	
	9.4.5.2	5	
6 H	6.2.2.1	15	15
7 E	5.2.1.1	17	19
	9.1.5.1	2	
	8.8.2.1	19	
8 Add.	9.1.5.1	2	6
	8.6.3.3	13	29
9.11.1.4	5		
9.9.3.4	11		
10 Add.	7.8.2.2	20	6
	9.1.4.2	4	
11 D	1.2.8.1	16	35
	9.1.1.2	8	
	9.9.4.2	11	
12 Add.	8.6.7.2	12	6
	9.1.3.2	4	
13 F	7.2.1.1	6	32
	9.1.3.8	12	
	9.4.3.3	8	
	9.1.3.3	6	
14 J	2.3.4.4	34	34
Total K = 322			

J

Check: 4-8-2019 19:26 OpenAero 2019.2.3 2019 civa advanced programme3 Sequence is correct

Pilot

A/C

ROU

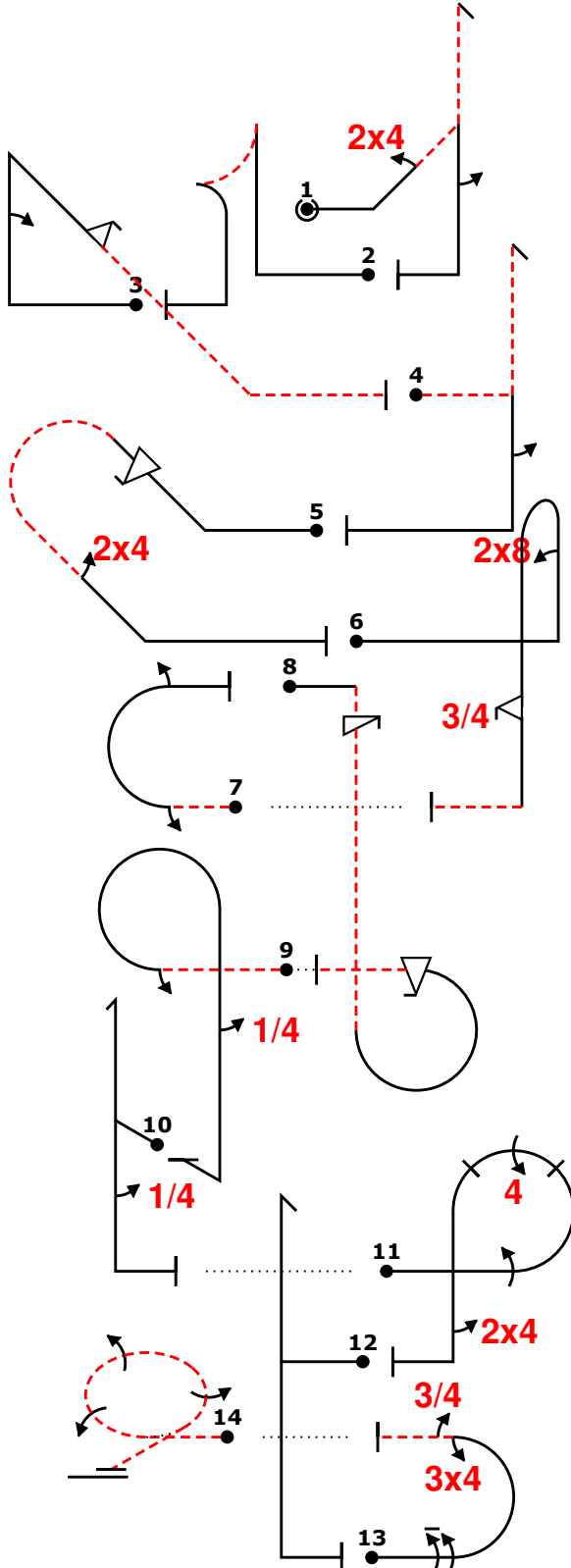
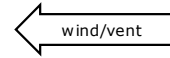

Power			
Fig	Aresti	K	
1 G	5.3.2.1	24	35
	9.4.2.2	7	
	9.1.5.2	4	
2 H	6.2.2.1	15	15
3 D	1.2.8.1	16	35
	9.1.1.2	8	
	9.9.4.2	11	
4 Add.	5.2.1.4	22	6
	9.1.5.2	4	
5 I	8.4.18.1	14	32
	9.9.2.4	13	
	9.4.4.2	5	
6 C	8.4.2.1	14	32
	9.8.1.1	7	
	9.9.5.3	11	
7 Add.	7.2.4.2	6	6
	9.1.3.2	4	
	9.1.3.2	4	
8 A	8.6.3.3	13	29
	9.11.1.4	5	
	9.9.3.4	11	
9 Add.	8.6.7.2	12	6
	9.1.3.2	4	
	9.1.5.1	2	
10 E	5.2.1.1	17	19
	9.1.5.1	2	
11 B	8.6.5.1	11	35
	9.1.3.4	8	
	9.4.3.4	11	
	9.4.5.2	5	
12 Add.	5.2.1.1	17	6
13 F	7.2.1.1	6	32
	9.1.3.8	12	
	9.4.3.3	8	
	9.1.3.3	6	
14 J	2.3.4.4	34	34
Total K = 322			

K

Pilot
.....
A/C