



France Doret/excellence SEP 2023
 connu EAC 23 PAVULLO, ITA

wind/vent ← **R**

Figure K
310
 Total K
345

Judges Name	
Signature	Number

Flight #
W/U 1

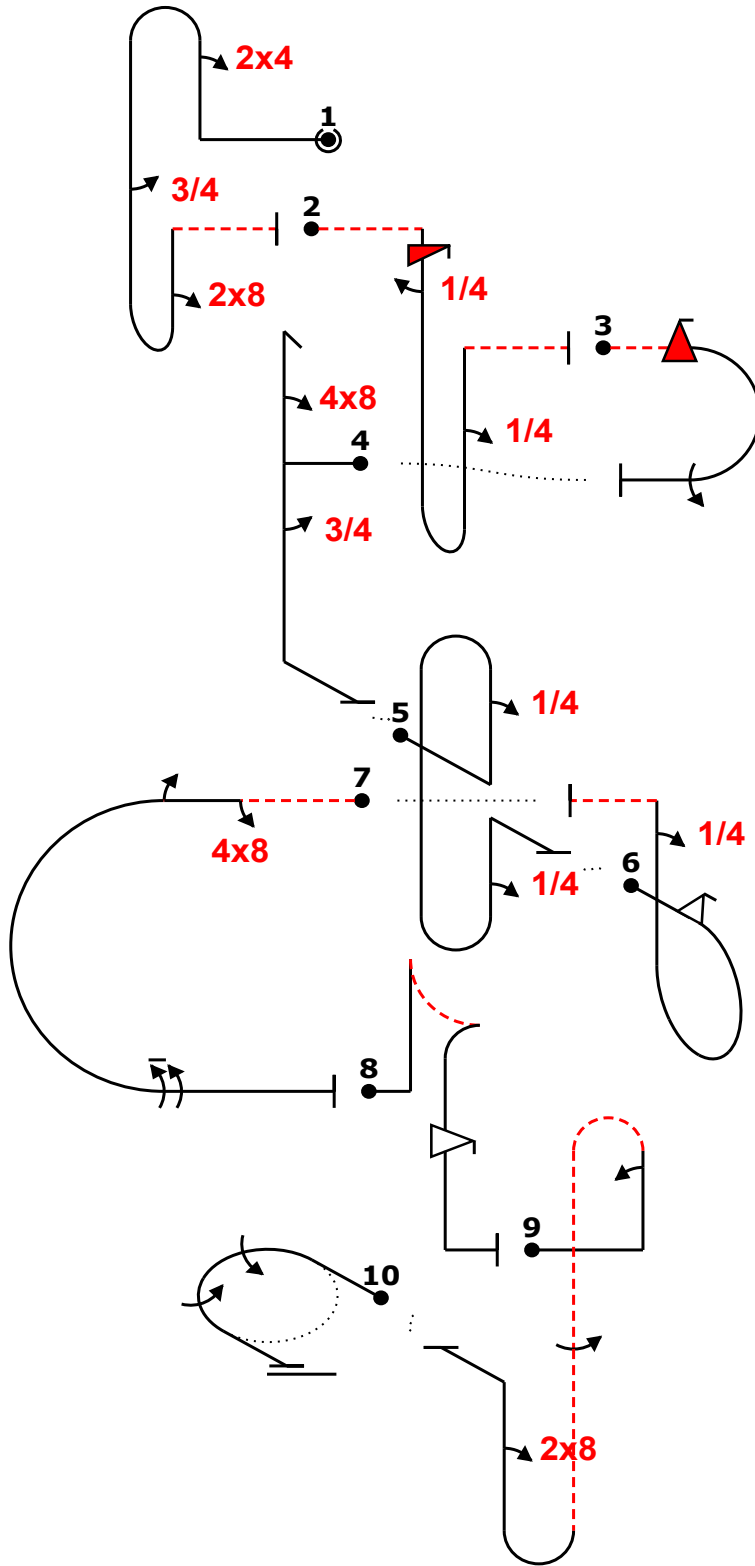

Fig	Grade	Pos	Remarks
1	.		
2	.		
3	.		
4	.		
5	.		
6	.		
7	.		
8	.		
9	.		
10	.		

Positioning
35

Too Low		Trg Violation	
Too High		Wing Rocks	
Interruptions		Disqual Fig	
Insertions		Other(note...)	

ed /~,24bb('3.),8- ~~~~~is,"[4...''ib,4'~> -ifal (-11,-1) ,48h3..+ (-1,0) ~~,4'bb('),4^ (1,0) ~~~2fi p,4~ (-8,0) 12% ~'48'',2a9 ~~~~~+ita''f.'+ ~~~~~2pbb(''1..')..8^ (0,-1) 2j2

Fig 1	K	Fig 2	K	Fig 3	K	Fig 4	K	Fig 5	K	Fig 6	K	Fig 7	K	Fig 8	K	Fig 9	K	Fig 10	K
8.8.1.1	18	8.4.1.4	13	7.2.1.4	6	5.2.1.1	17	8.8.2.1	19	8.6.7.3	12	7.2.1.4	6	6.2.2.1	15	8.8.6.1	21	2.2.5.1	22
9.4.1.2	9	9.12.1.4	7	9.10.3.4	13	9.8.1.2	11	9.1.1.1	6	9.9.3.2	11	9.8.3.2	7	9.9.5.4	11	9.1.1.2	8		
9.1.5.3	6	9.1.5.1	2	9.1.3.4	8	9.1.5.3	6	9.1.1.1	6	9.1.1.1	6	9.1.3.2	4			9.1.5.4	8		
9.8.1.1	7	9.1.1.1	6									9.1.3.8	12			9.8.1.1	7		
	40		28		27		34		31		29		29		26		44		22

Pilot: **CRESCI RICARDO**

A/C: **EXTRA 330 SC F-HLAS**



France Doret/excellence SEP 2023
 connu EAC 23 PAVULLO, ITA

Figure K
310
 Total K
345

Judges Name	
Signature	Number

Flight #
W/U 1

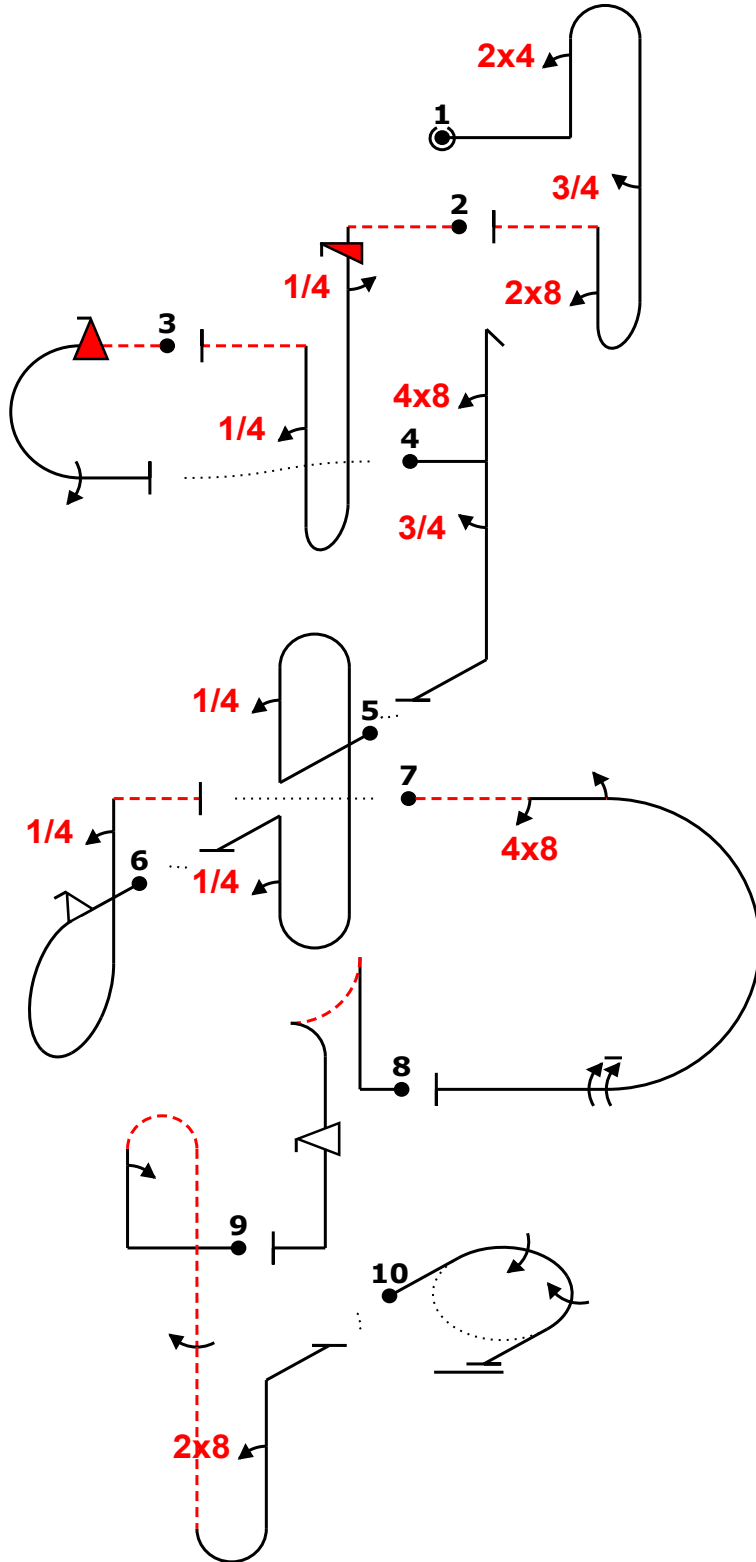
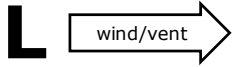

Fig	Grade	Pos	Remarks
1	.		
2	.		
3	.		
4	.		
5	.		
6	.		
7	.		
8	.		
9	.		
10	.		

Positioning
35

Too Low		Trg Violation	
Too High		Wing Rocks	
Interruptions		Disqual Fig	
Insertions		Other(note...)	

ed /~24bb(3.),8-is,"4...''ib,4'~> -ifal (-11,-1) ,48h3..+ (-1,0) ~~,4'bb('),4^ (1,0) '''2fi p,4~ (-8,0) 12% ~'48''2a9+ita' f.'+ 2pbb('1..') ,8^ (0,-1) 2j2

Fig 1	K	Fig 2	K	Fig 3	K	Fig 4	K	Fig 5	K	Fig 6	K	Fig 7	K	Fig 8	K	Fig 9	K	Fig 10	K
8.8.1.1	18	8.4.1.4	13	7.2.1.4	6	5.2.1.1	17	8.8.2.1	19	8.6.7.3	12	7.2.1.4	6	6.2.2.1	15	8.8.6.1	21	2.2.5.1	22
9.4.1.2	9	9.12.1.4	7	9.10.3.4	13	9.8.1.2	11	9.1.1.1	6	9.9.3.2	11	9.8.3.2	7	9.9.5.4	11	9.1.1.2	8		
9.1.5.3	6	9.1.5.1	2	9.1.3.4	8	9.1.5.3	6	9.1.1.1	6	9.1.1.1	6	9.1.3.2	4			9.1.5.4	8		
9.8.1.1	7	9.1.1.1	6									9.1.3.8	12			9.8.1.1	7		
	40		28		27		34		31		29		29		26		44		22

Pilot: CRESCI RICARDO

A/C: EXTRA 330 SC F-HLAS

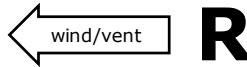

Figure K
450
Total K
490

Judges Name	
Signature	Number

Flight # W/U 2

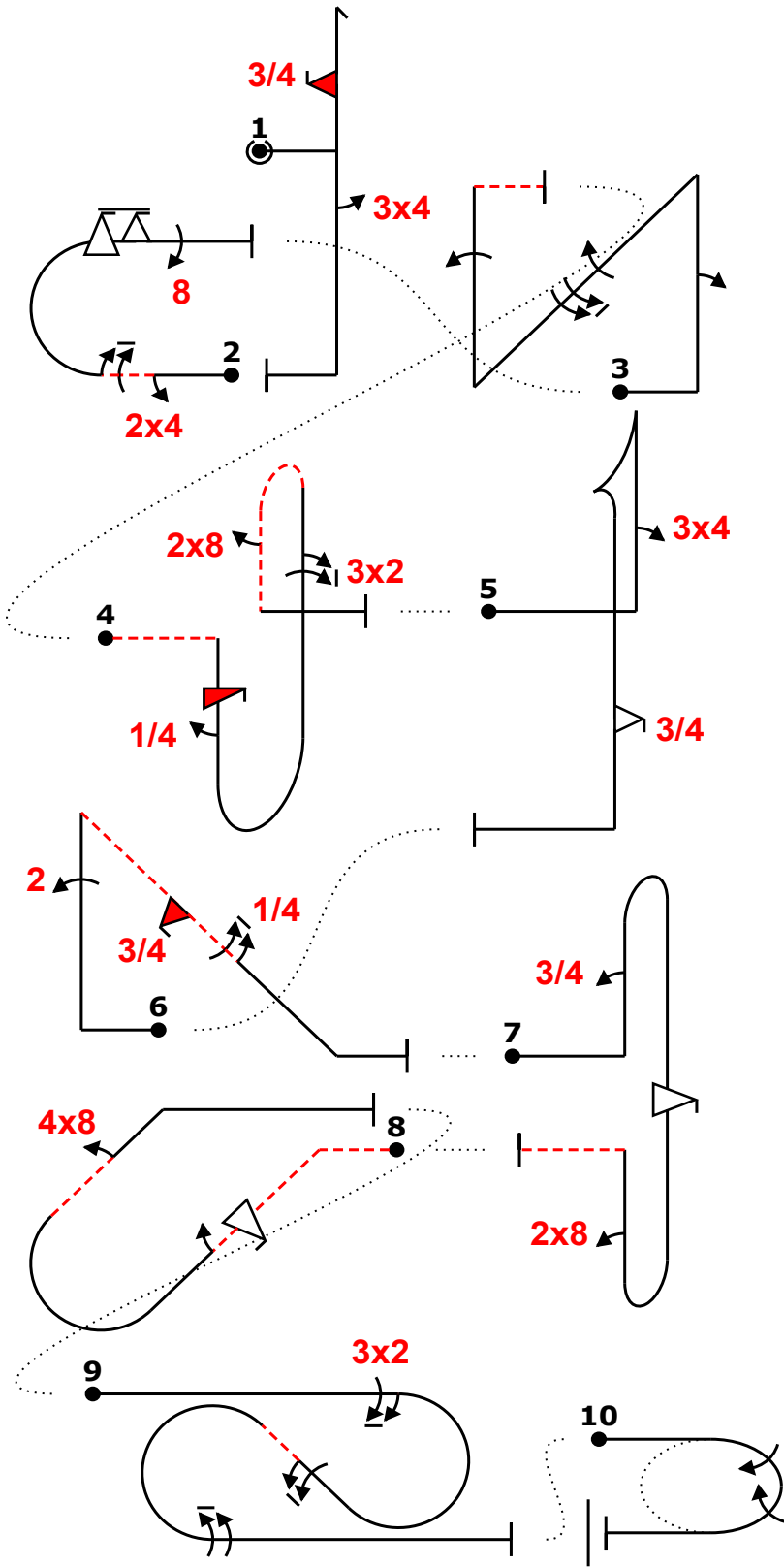

Fig	Grade	Pos	Remarks
1	.		
2	.		
3	.		
4	.		
5	.		
6	.		
7	.		
8	.		
9	.		
10	.		

Positioning 40	.
--------------------------	---

Too Low		Trg Violation	
Too High		Wing Rocks	
Interruptions		Disqual Fig	
Insertions		Other(note...)	

Fig 1 A	K	Fig 2 B	K	Fig 3	K	Fig 4 E	K	Fig 5	K	Fig 6 D	K	Fig 7	K	Fig 8 C	K	Fig 9	K	Fig 10	K
5.2.1.1	17	7.2.2.1	6	1.3.14.1	22	8.8.3.4	20	6.2.1.1	15	1.2.7.1	13	8.8.1.1	18	8.4.16.4	14	7.5.5.3	15	2.2.5.1	22
9.10.6.3	19	9.4.3.2	5	9.1.1.2	8	9.12.1.4	7	9.4.1.3	12	9.2.1.4	13	9.1.1.3	10	9.9.9.4	13	9.2.3.6	12		
9.4.5.3	8	9.1.3.6	10	9.1.4.4	8	9.1.5.1	2	9.9.5.3	11	9.10.4.3	13	9.9.5.4	11	9.1.4.2	4	9.1.2.6	12		
		9.9.3.6	14	9.1.4.8	12	9.2.1.6	17			9.1.4.5	9	9.8.1.1	7	9.8.2.2	9	9.1.3.8	12		
		9.8.3.4	15	9.1.1.4	12	9.8.5.1	3												
	44		50		62		49		38		48		46		40		51		22



Figure K
450
Total K
490

Judges Name	
Signature	Number

Flight # W/U 2

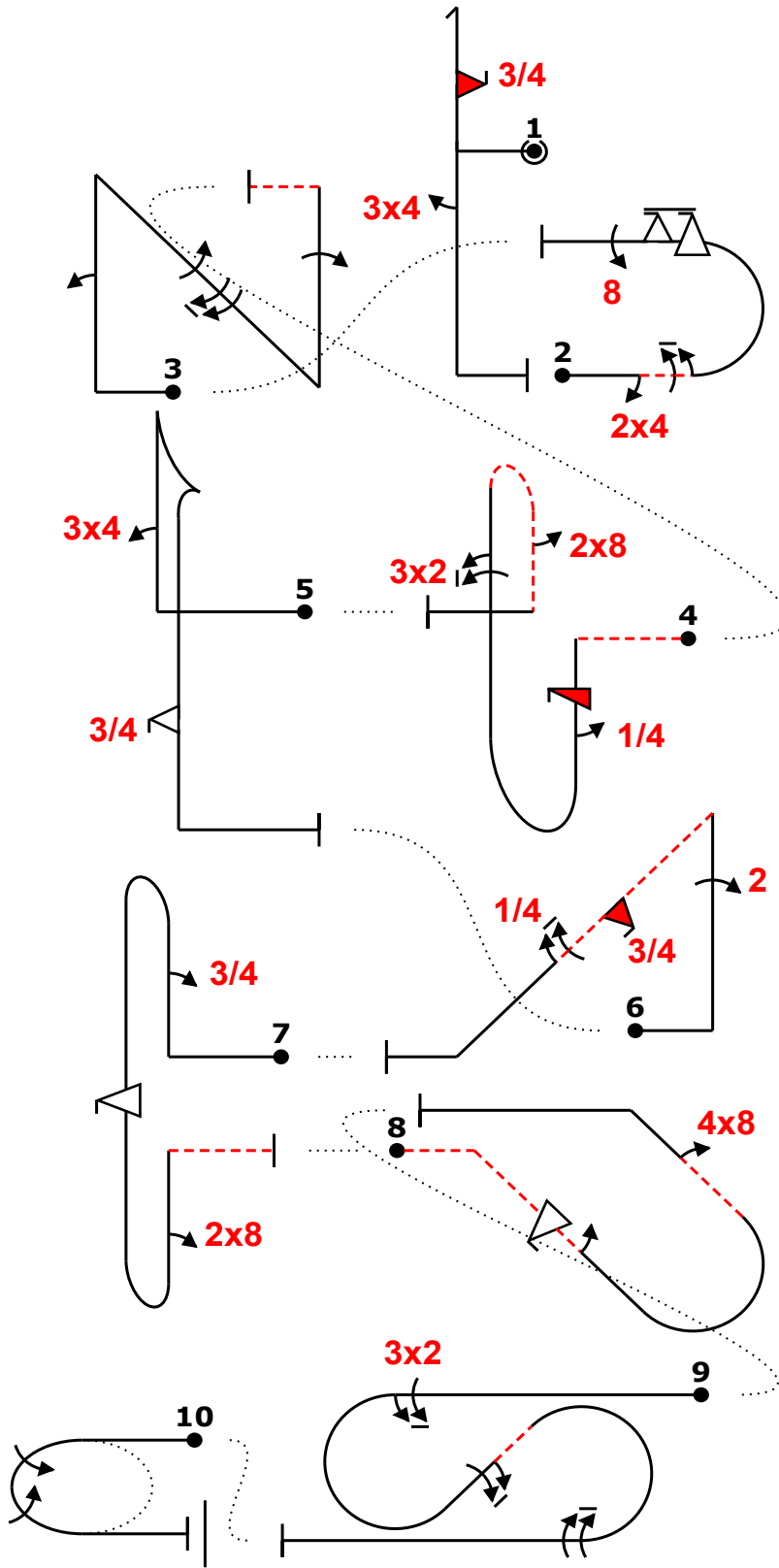
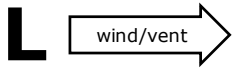

Fig	Grade	Pos	Remarks
1	.		
2	.		
3	.		
4	.		
5	.		
6	.		
7	.		
8	.		
9	.		
10	.		

Positioning 40	.
-------------------	---

Too Low		Trg Violation	
Too High		Wing Rocks	
Interruptions		Disqual Fig	
Insertions		Other(note...)	

Fig 1 A	K	Fig 2 B	K	Fig 3	K	Fig 4 E	K	Fig 5	K	Fig 6 D	K	Fig 7	K	Fig 8 C	K	Fig 9	K	Fig 10	K
5.2.1.1	17	7.2.2.1	6	1.3.14.1	22	8.8.3.4	20	6.2.1.1	15	1.2.7.1	13	8.8.1.1	18	8.4.16.4	14	7.5.5.3	15	2.2.5.1	22
9.10.6.3	19	9.4.3.2	5	9.1.1.2	8	9.12.1.4	7	9.4.1.3	12	9.2.1.4	13	9.1.1.3	10	9.9.9.4	13	9.2.3.6	12		
9.4.5.3	8	9.1.3.6	10	9.1.4.4	8	9.1.5.1	2	9.9.5.3	11	9.10.4.3	13	9.9.5.4	11	9.1.4.2	4	9.1.2.6	12		
		9.9.3.6	14	9.1.4.8	12	9.2.1.6	17			9.1.4.5	9	9.8.1.1	7	9.8.2.2	9	9.1.3.8	12		
		9.8.3.4	15	9.1.1.4	12	9.8.5.1	3												
	44		50		62		49		38		48		46		40		51		22

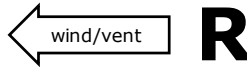

Figure K
450
Total K
490

Judges Name	
Signature	Number

Flight # 01

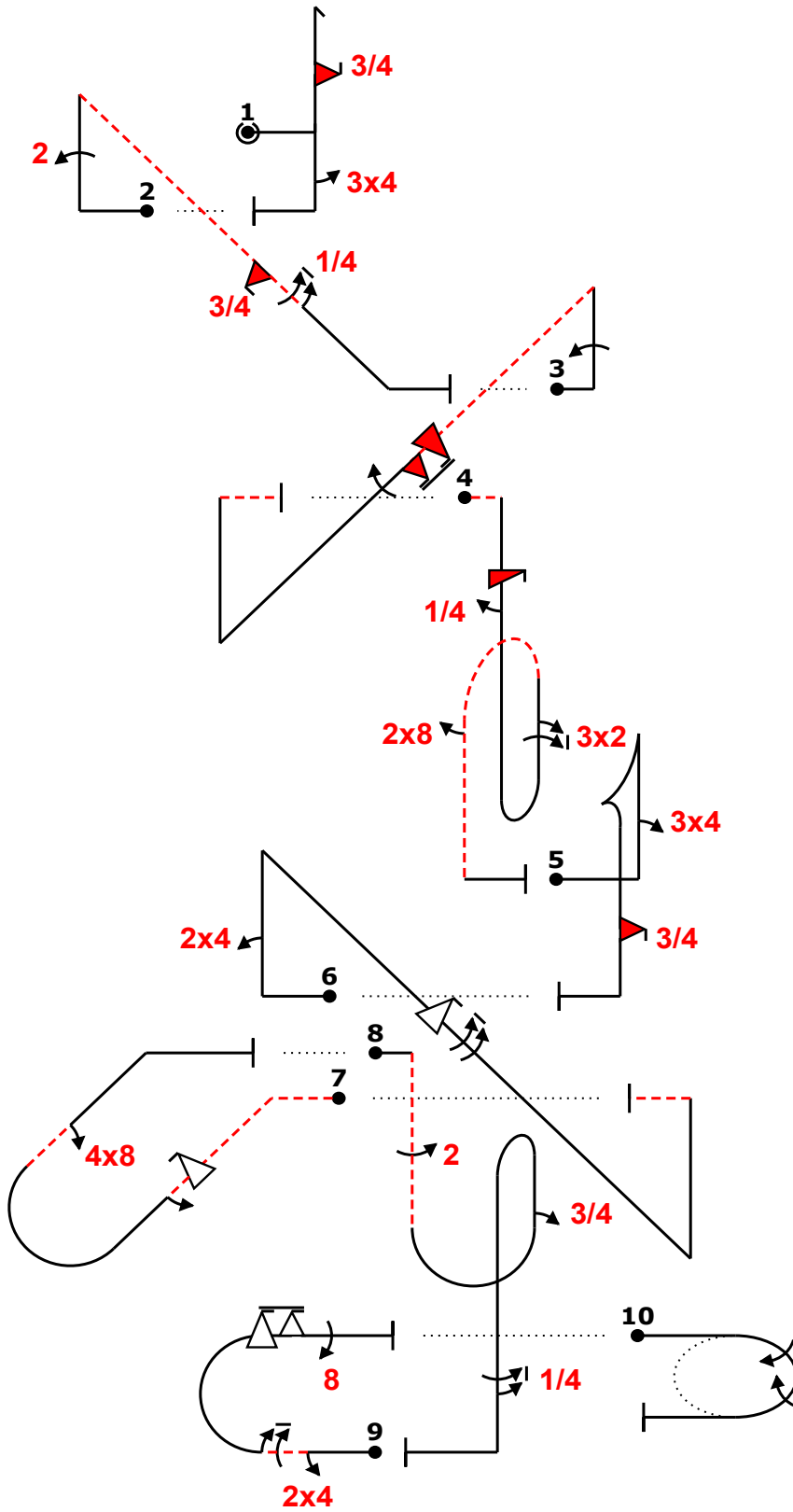

Fig	Grade	Pos	Remarks
1	.		
2	.		
3	.		
4	.		
5	.		
6	.		
7	.		
8	.		
9	.		
10	.		

Positioning 40	.
-------------------	---

Too Low		Trg Violation	
Too High		Wing Rocks	
Interruptions		Disqual Fig	
Insertions		Other(note...)	

Fig 1 A	K	Fig 2 D	K	Fig 3	K	Fig 4 E	K	Fig 5	K	Fig 6	K	Fig 7 C	K	Fig 8	K	Fig 9 B	K	Fig 10	K
5.2.1.1	17	1.2.7.1	13	1.3.11.1	20	8.8.3.4	20	6.2.1.1	15	1.3.14.1	22	8.4.16.4	14	8.8.8.3	19	7.2.2.1	6	2.2.5.1	22
9.10.6.3	19	9.2.1.4	13	9.1.1.4	12	9.12.1.4	7	9.4.1.3	12	9.4.1.2	9	9.9.9.4	13	9.2.5.4	9	9.4.3.2	5		
9.4.5.3	8	9.10.4.3	13	9.10.4.6	16	9.1.5.1	2	9.10.5.3	13	9.9.4.4	11	9.1.4.2	4	9.1.1.3	10	9.1.3.6	10		
		9.1.4.5	9	9.1.4.4	8	9.2.1.6	17			9.1.4.8	12	9.8.2.2	9	9.1.5.5	9	9.9.3.6	14		
						9.8.5.1	3									9.8.3.4	15		
	44		48		56		49		40		54		40		47		50		22



Figure K
450
Total K
490

Judges Name	
Signature	Number

Flight # 01

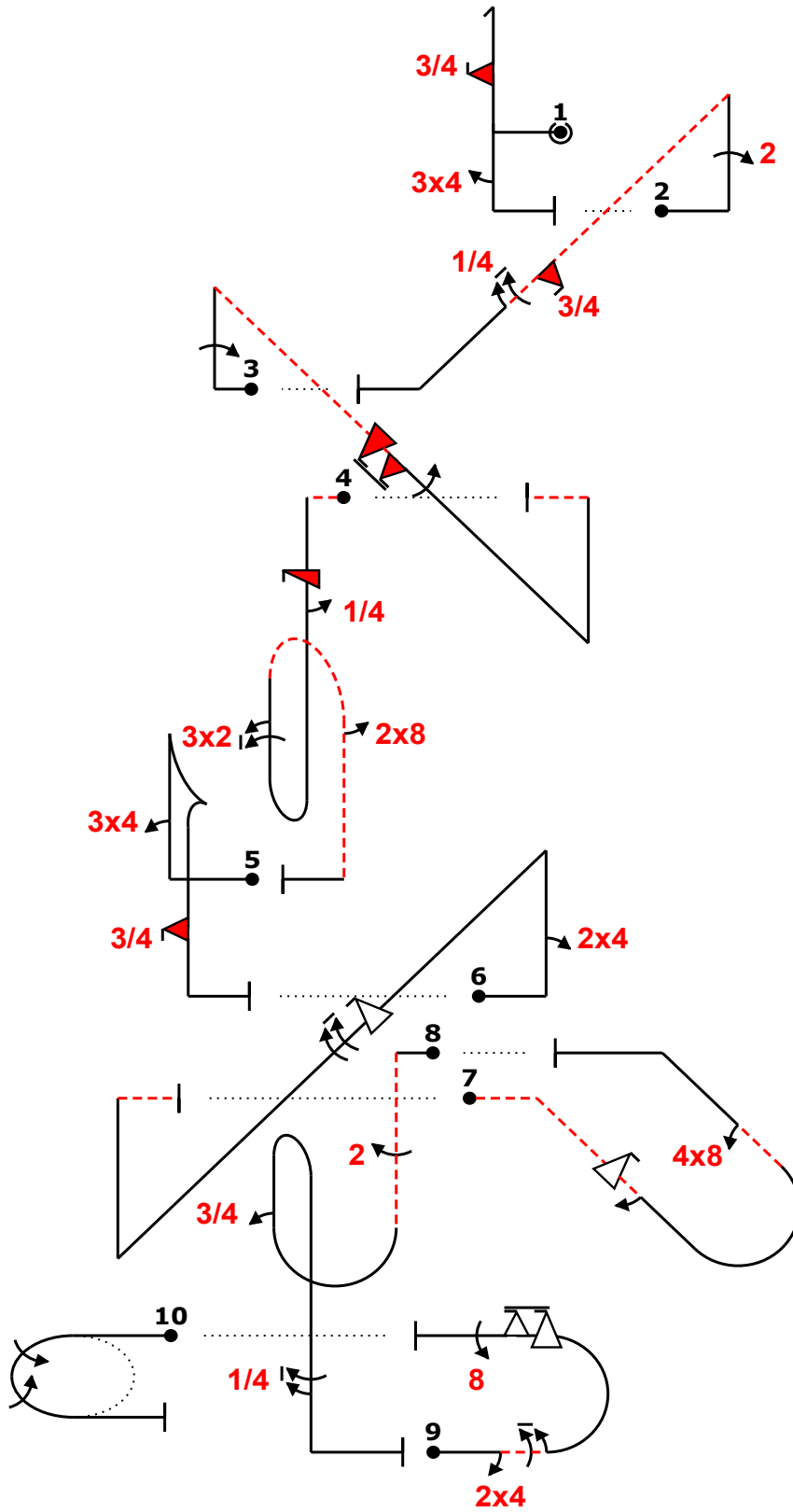
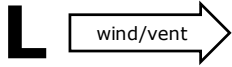

Fig	Grade	Pos	Remarks
1	.		
2	.		
3	.		
4	.		
5	.		
6	.		
7	.		
8	.		
9	.		
10	.		

Positioning 40	.
-------------------	---

Too Low		Trg Violation	
Too High		Wing Rocks	
Interruptions		Disqual Fig	
Insertions		Other(note...)	

Fig 1 A	K	Fig 2 D	K	Fig 3	K	Fig 4 E	K	Fig 5	K	Fig 6	K	Fig 7 C	K	Fig 8	K	Fig 9 B	K	Fig 10	K
5.2.1.1	17	1.2.7.1	13	1.3.11.1	20	8.8.3.4	20	6.2.1.1	15	1.3.14.1	22	8.4.16.4	14	8.8.8.3	19	7.2.2.1	6	2.2.5.1	22
9.10.6.3	19	9.2.1.4	13	9.1.1.4	12	9.12.1.4	7	9.4.1.3	12	9.4.1.2	9	9.9.9.4	13	9.2.5.4	9	9.4.3.2	5		
9.4.5.3	8	9.10.4.3	13	9.10.4.6	16	9.1.5.1	2	9.10.5.3	13	9.9.4.4	11	9.1.4.2	4	9.1.1.3	10	9.1.3.6	10		
		9.1.4.5	9	9.1.4.4	8	9.2.1.6	17			9.1.4.8	12	9.8.2.2	9	9.1.5.5	9	9.9.3.6	14		
						9.8.5.1	3									9.8.3.4	15		
	44		48		56		49		40		54		40		47		50		22

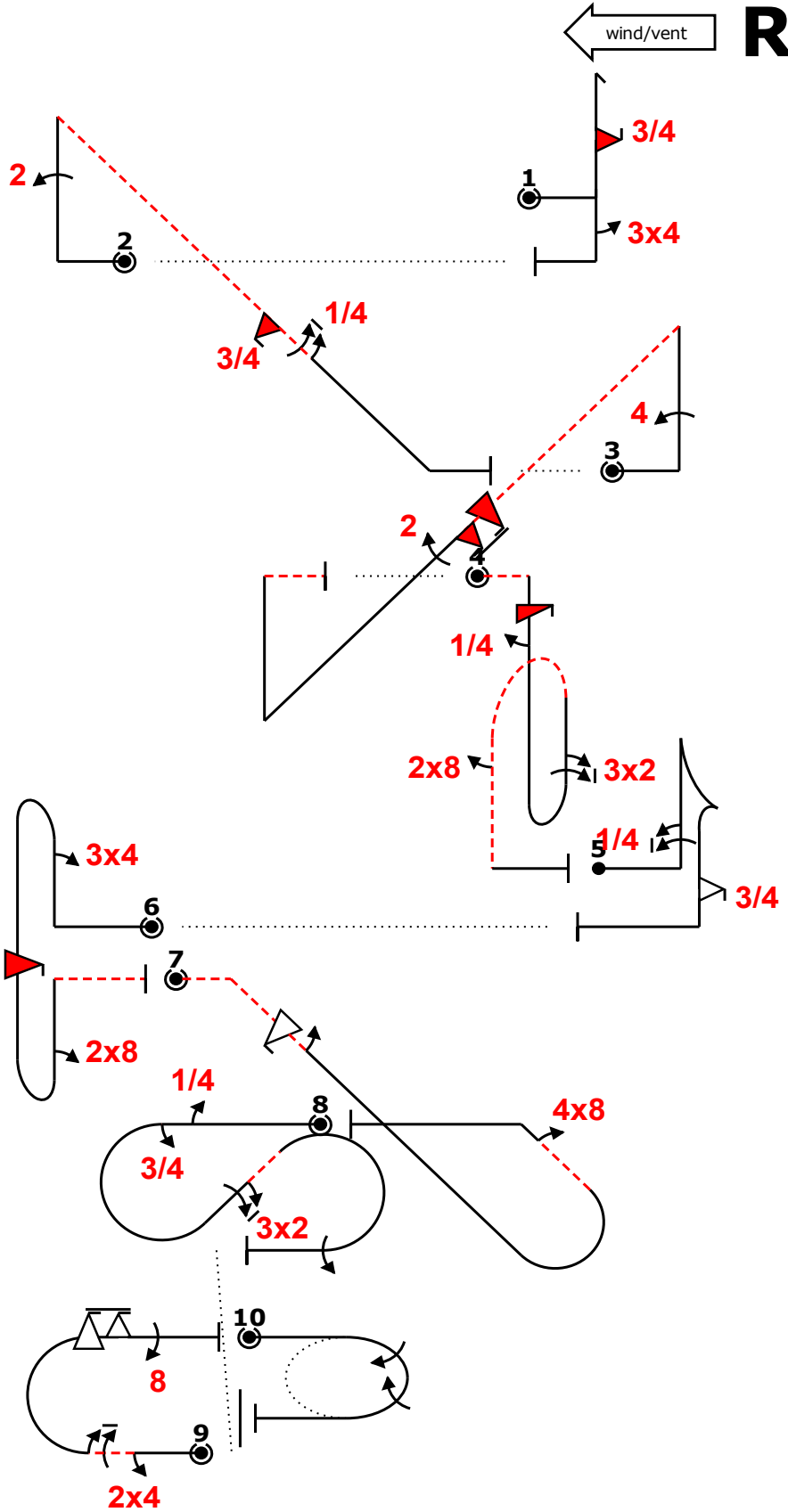

Fig	Grade	Pos	Remarks
1	.		
2	.		
3	.		
4	.		
5	.		
6	.		
7	.		
8	.		
9	.		
10	.		

Positioning 40	.
-------------------	---

Too Low		Trg Violation	
Too High		Wing Rocks	
Interruptions		Disqual Fig	
Insertions		Other(note...)	

"@A" ,3ifh'34 (-23,0) ed "@D" 22k....,3if,5. (4,0) eu 44n(...'6if,22....) - (6,0) eu "@E"is,4..
 .'ibpB(.....,32),8.+> /' +5ta' 3f (-24,0) ed ,34bb(if''),8' - eu eu -2% -,f,2.....'indb,48~
 ed ,4,3iac,(32)1+ [1,14] ed "@B" 24,6m6f,88 eu 2j2

Fig 1 A	K	Fig 2 D	K	Fig 3	K	Fig 4 E	K	Fig 5	K	Fig 6	K	Fig 7	K	Fig 8	K	Fig 9 B	K	Fig 10	K
5.2.1.1	17	1.2.7.1	13	1.3.11.1	20	8.8.3.4	20	6.2.1.1	15	8.8.1.1	18	8.4.16.4	14	7.5.5.3	15	7.2.2.1	6	2.2.5.1	22
9.10.6.3	19	9.2.1.4	13	9.4.1.4	15	9.12.1.4	7	9.1.1.5	14	9.4.1.3	12	9.9.9.4	13	9.1.3.1	2	9.4.3.2	5		
9.4.5.3	8	9.10.4.3	13	9.10.4.6	16	9.1.5.1	2	9.9.5.3	11	9.10.10.4	15	9.1.4.2	4	9.1.3.3	6	9.1.3.6	10		
		9.1.4.5	9	9.2.4.4	9	9.2.1.6	17			9.8.1.1	7	9.8.2.2	9	9.2.2.6	14	9.9.3.6	14		
						9.8.5.1	3					9.1.3.4	8	9.1.3.4	8	9.8.3.4	15		
	44		48		60		49		40		52		40		45		50		22



Figure K
450
Total K
490

Judges Name
Signature
Number

Flight #
02

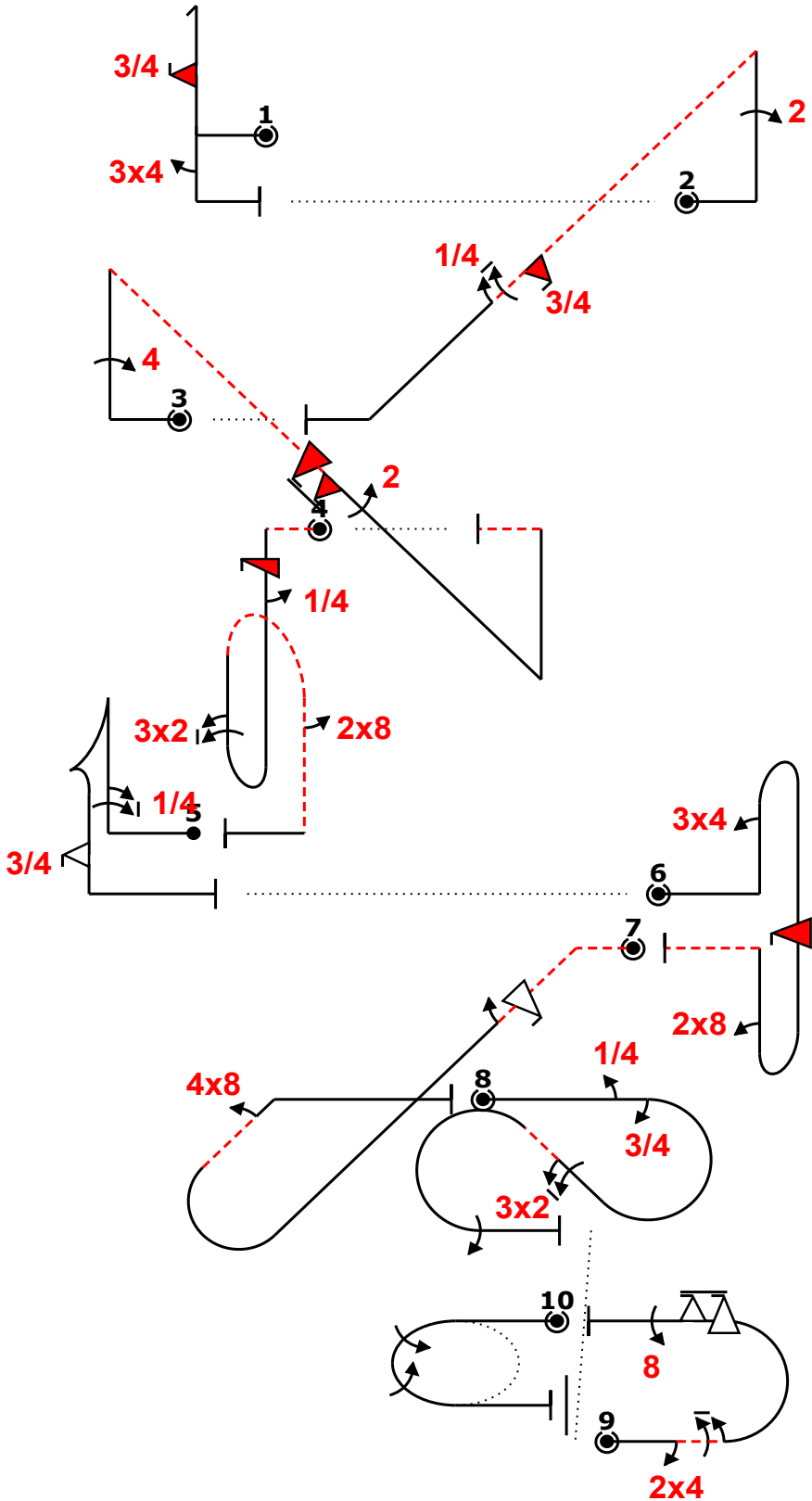
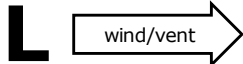

Fig	Grade	Pos	Remarks
1	.		
2	.		
3	.		
4	.		
5	.		
6	.		
7	.		
8	.		
9	.		
10	.		

Positioning
40 .

Too Low		Trg Violation	
Too High		Wing Rocks	
Interruptions		Disqual Fig	
Insertions		Other(note...)	

"@A" ,3ifh'34 (-23,0) ed "@D" 22k....,3if,5. (4,0) eu 44n(...'6if,22....) - (6,0) eu "@E"is,4..
'ibpB(.....,32),8.+> /' +5ta' 3f (-24,0) ed ,34bb(if''),8'- eu eu -2% -,f,2.....'irdb,48~
ed ,4,3iac,(32)1+ [1,14] ed "@B" 24,6mf,88 eu 2j2

Fig 1 A	K	Fig 2 D	K	Fig 3	K	Fig 4 E	K	Fig 5	K	Fig 6	K	Fig 7	K	Fig 8	K	Fig 9 B	K	Fig 10	K
5.2.1.1	17	1.2.7.1	13	1.3.11.1	20	8.8.3.4	20	6.2.1.1	15	8.8.1.1	18	8.4.16.4	14	7.5.5.3	15	7.2.2.1	6	2.2.5.1	22
9.10.6.3	19	9.2.1.4	13	9.4.1.4	15	9.12.1.4	7	9.1.1.5	14	9.4.1.3	12	9.9.9.4	13	9.1.3.1	2	9.4.3.2	5		
9.4.5.3	8	9.10.4.3	13	9.10.4.6	16	9.1.5.1	2	9.9.5.3	11	9.10.10.4	15	9.1.4.2	4	9.1.3.3	6	9.1.3.6	10		
		9.1.4.5	9	9.2.4.4	9	9.2.1.6	17			9.8.1.1	7	9.8.2.2	9	9.2.2.6	14	9.9.3.6	14		
						9.8.5.1	3							9.1.3.4	8	9.8.3.4	15		
	44		48		60		49		40		52		40		45		50		22

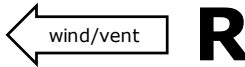

Figure K
 450
 Total K
 490

Judges Name	
Signature	Number

Flight # 03

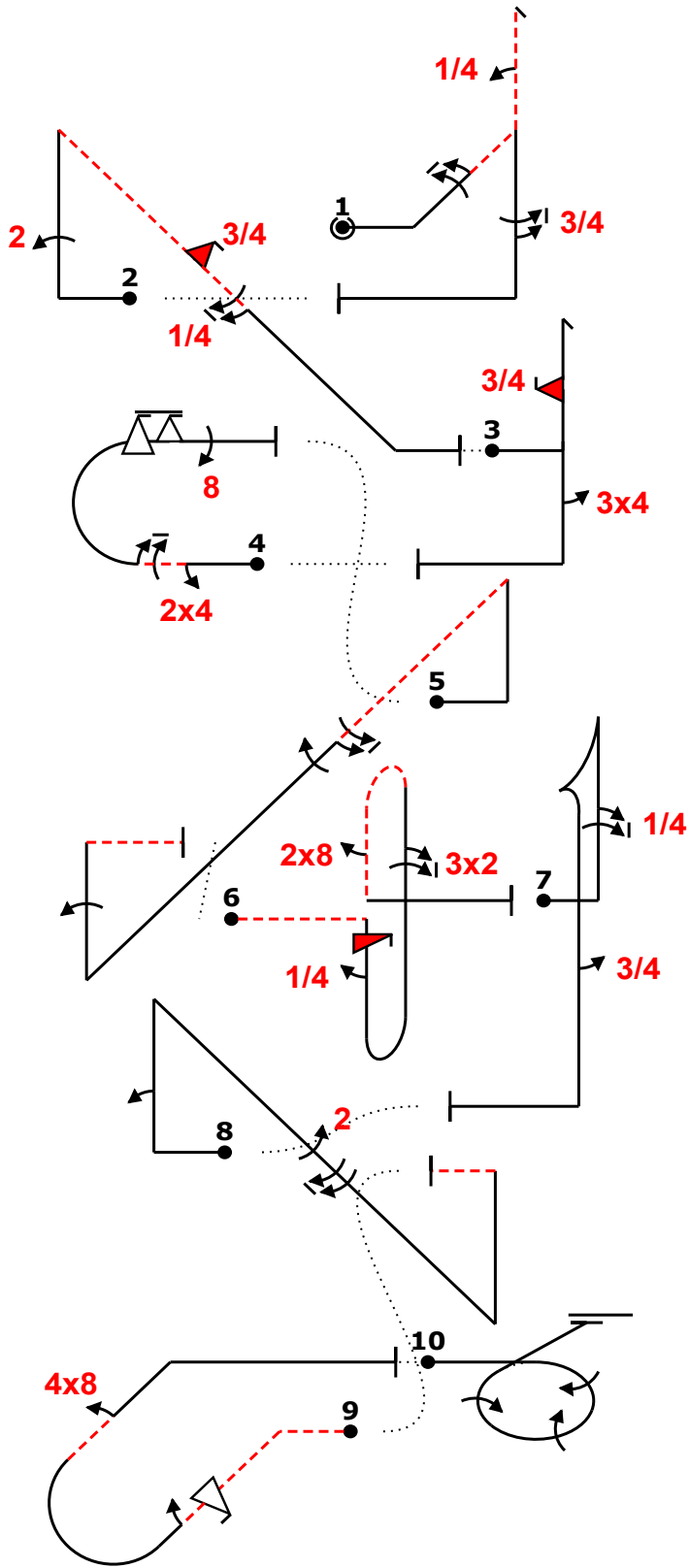

Fig	Grade	Pos	Remarks
1	.		
2	.		
3	.		
4	.		
5	.		
6	.		
7	.		
8	.		
9	.		
10	.		

Positioning 40	.
-------------------	---

Too Low		Trg Violation	
Too High		Wing Rocks	
Interruptions		Disqual Fig	
Insertions		Other(note...)	

Fig 1	K	Fig 2 D	K	Fig 3 A	K	Fig 4 B	K	Fig 5	K	Fig 6 E	K	Fig 7	K	Fig 8	K	Fig 9 C	K	Fig 10	K
5.3.2.1	24	1.2.7.1	13	5.2.1.1	17	7.2.2.1	6	1.3.11.1	20	8.8.3.4	20	6.2.1.1	15	1.3.14.1	22	8.4.16.4	14	2.3.4.1	30
9.1.2.6	12	9.2.1.4	13	9.10.6.3	19	9.4.3.2	5	9.1.4.6	10	9.12.1.4	7	9.1.1.5	14	9.1.1.2	8	9.9.9.4	13		
9.1.1.1	6	9.10.4.3	13	9.4.5.3	8	9.1.3.6	10	9.1.4.4	8	9.1.5.1	2	9.1.5.3	6	9.2.4.4	9	9.1.4.2	4		
9.1.5.7	11	9.1.4.5	9			9.9.3.6	14	9.1.1.4	12	9.2.1.6	17			9.1.4.8	12	9.8.2.2	9		
	53		48		44	9.8.3.4	15			9.8.5.1	3								30
							50				49				51				40



Figure K
 450
 Total K
 490

Judges Name	
Signature	Number

Flight #
03

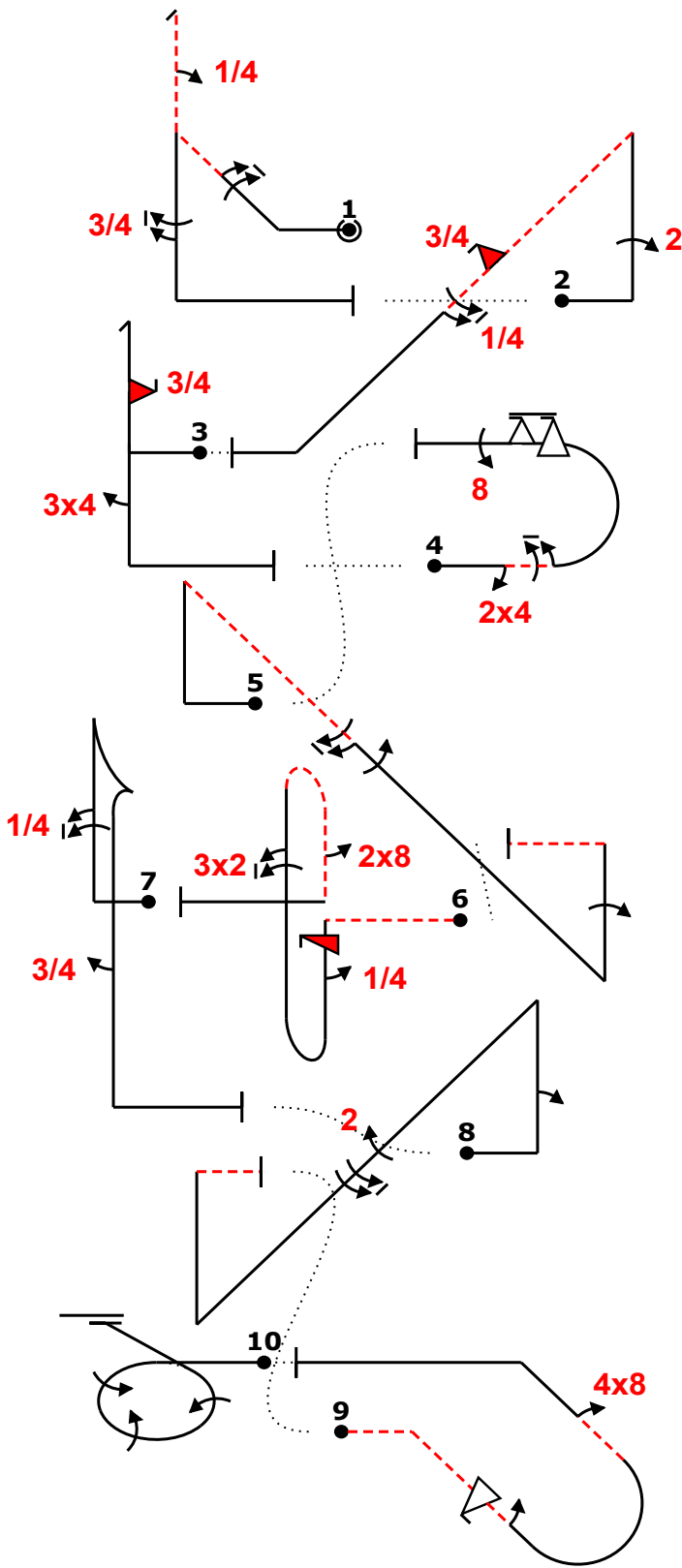
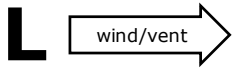

Fig	Grade	Pos	Remarks
1	.		
2	.		
3	.		
4	.		
5	.		
6	.		
7	.		
8	.		
9	.		
10	.		

Positioning
 40

Too Low		Trg Violation	
Too High		Wing Rocks	
Interruptions		Disqual Fig	
Insertions		Other(note...)	

Fig 1	K	Fig 2 D	K	Fig 3 A	K	Fig 4 B	K	Fig 5	K	Fig 6 E	K	Fig 7	K	Fig 8	K	Fig 9 C	K	Fig 10	K
5.3.2.1	24	1.2.7.1	13	5.2.1.1	17	7.2.2.1	6	1.3.11.1	20	8.8.3.4	20	6.2.1.1	15	1.3.14.1	22	8.4.16.4	14	2.3.4.1	30
9.1.2.6	12	9.2.1.4	13	9.10.6.3	19	9.4.3.2	5	9.1.4.6	10	9.12.1.4	7	9.1.1.5	14	9.1.1.2	8	9.9.9.4	13		
9.1.1.1	6	9.10.4.3	13	9.4.5.3	8	9.1.3.6	10	9.1.4.4	8	9.1.5.1	2	9.1.5.3	6	9.2.4.4	9	9.1.4.2	4		
9.1.5.7	11	9.1.4.5	9			9.9.3.6	14	9.1.1.4	12	9.2.1.6	17			9.1.4.8	12	9.8.2.2	9		
						9.8.3.4	15			9.8.5.1	3								
	53		48		44		50		50		49		35		51		40		30

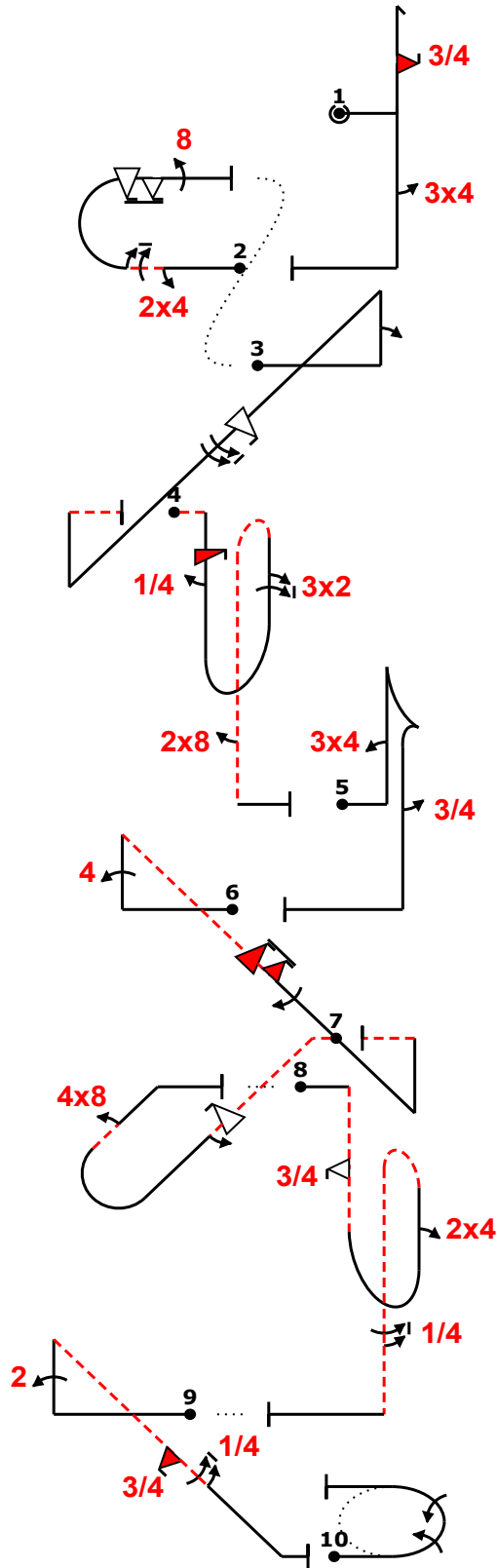
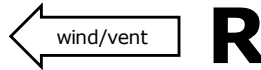

Fig	Grade	Pos	Remarks
1	.		
2	.		
3	.		
4	.		
5	.		
6	.		
7	.		
8	.		
9	.		
10	.		

Positioning 40	.
-------------------	---

Too Low		Trg Violation	
Too High		Wing Rocks	
Interruptions		Disqual Fig	
Insertions		Other(note...)	

"@A" ,3ifh.34.'+~ (0,0) "@B" -1% "24,6m,6f,88 (-2,15) ~~~~+2'~pn(..f;9...)" (0,0) "@E" ~~~~
 'is,4.' 'ibpb(' ,32') ,8'+> (0,0) /.....+34ta' 3..... (0,0) ~+44' n(..6if,1...)' -"@C"
 -3%f,2.....'irdb' 48.'+..... (2,0) 1% '+',3f.iBpb(' ,24').....'5'~^ (-2,0) "@D" +.....22'k.
 ' ,3if,5+.....+2j2+> eu eu eu eu eu eu eu eu eu eu

Fig 1 A	K	Fig 2 B	K	Fig 3	K	Fig 4 E	K	Fig 5	K	Fig 6	K	Fig 7 C	K	Fig 8	K	Fig 9 D	K	Fig 10	K
5.2.1.1	17	7.2.2.1	6	1.3.14.1	22	8.8.3.4	20	6.2.1.1	15	1.3.11.1	20	8.4.16.4	14	8.8.6.3	21	1.2.7.1	13	2.2.5.1	22
9.10.6.3	19	9.4.3.2	5	9.1.1.2	8	9.12.1.4	7	9.4.1.3	12	9.4.1.4	15	9.9.9.4	13	9.9.10.3	13	9.2.1.4	13		
9.4.5.3	8	9.1.3.6	10	9.9.4.4	11	9.1.5.1	2	9.1.5.3	6	9.10.4.6	16	9.1.4.2	4	9.4.1.2	9	9.10.4.3	13		
		9.9.3.6	14	9.1.4.8	12	9.2.1.6	17	9.1.4.4	8	9.8.2.2	9	9.1.5.5	9	9.1.4.5	9				
		9.8.3.4	15			9.8.5.1	3												
	44		50		53		49		33		59		40		52		48		22



CIVA Unlimited

Free Known

Figure K

450

Total K

490

Judges Name

Flight #

04

Signature

Number

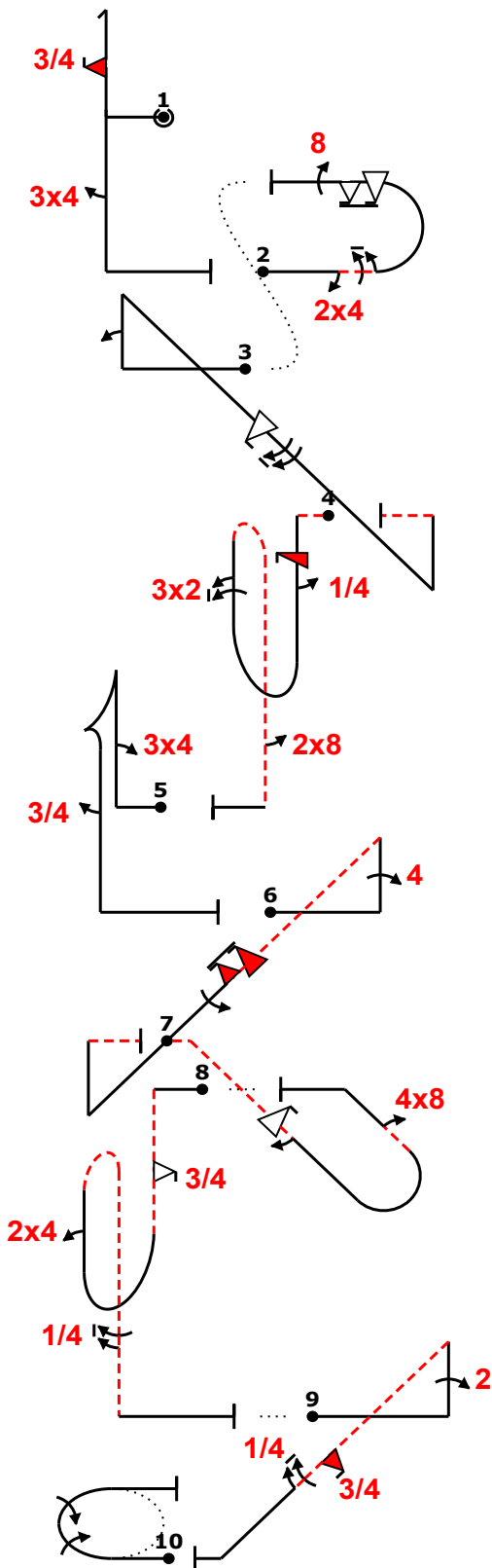
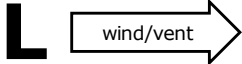

Fig	Grade	Pos	Remarks
1	.		
2	.		
3	.		
4	.		
5	.		
6	.		
7	.		
8	.		
9	.		
10	.		

Positioning

40

.

Too Low		Trg Violation	
Too High		Wing Rocks	
Interruptions		Disqual Fig	
Insertions		Other(note...)	

"@A" ,3ifh.34.'+~ (0,0) "@B" -1% "24,6m,6f,88 (-2,15) ~~~+,2'pn(..'f;9...)" (0,0) "@E" ~~~~
 'is,4.' 'ibpb('...32')...',8'+> (0,0) /...+.34ta' 3... (0,0) ~+44' n(..6if,1...)' - "@C"
 -3%...f,2...'irdb' 48.'+' (2,0) 1% '+',3f.ibpb('...24')... '5'~^ (-2,0) "@D" +~' 22'k.
 ' ',3if,5+...+2j2+> eu eu eu eu eu eu eu eu eu eu

Fig 1 A	K	Fig 2 B	K	Fig 3	K	Fig 4 E	K	Fig 5	K	Fig 6	K	Fig 7 C	K	Fig 8	K	Fig 9 D	K	Fig 10	K
5.2.1.1	17	7.2.2.1	6	1.3.14.1	22	8.8.3.4	20	6.2.1.1	15	1.3.11.1	20	8.4.16.4	14	8.8.6.3	21	1.2.7.1	13	2.2.5.1	22
9.10.6.3	19	9.4.3.2	5	9.1.1.2	8	9.12.1.4	7	9.4.1.3	12	9.4.1.4	15	9.9.9.4	13	9.9.10.3	13	9.2.1.4	13		
9.4.5.3	8	9.1.3.6	10	9.9.4.4	11	9.1.5.1	2	9.1.5.3	6	9.10.4.6	16	9.1.4.2	4	9.4.1.2	9	9.10.4.3	13		
		9.9.3.6	14	9.1.4.8	12	9.2.1.6	17			9.1.4.4	8	9.8.2.2	9	9.1.5.5	9	9.1.4.5	9		
		9.8.3.4	15			9.8.5.1	3												
	44		50		53		49		33		59		40		52		48		22

Pilot: Louis VANEL

A/C: E330SC FHMKF

Team: FRA

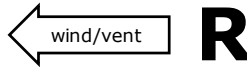

Figure K
450
Total K
490

Judges Name	
Signature	Number

Flight # 05

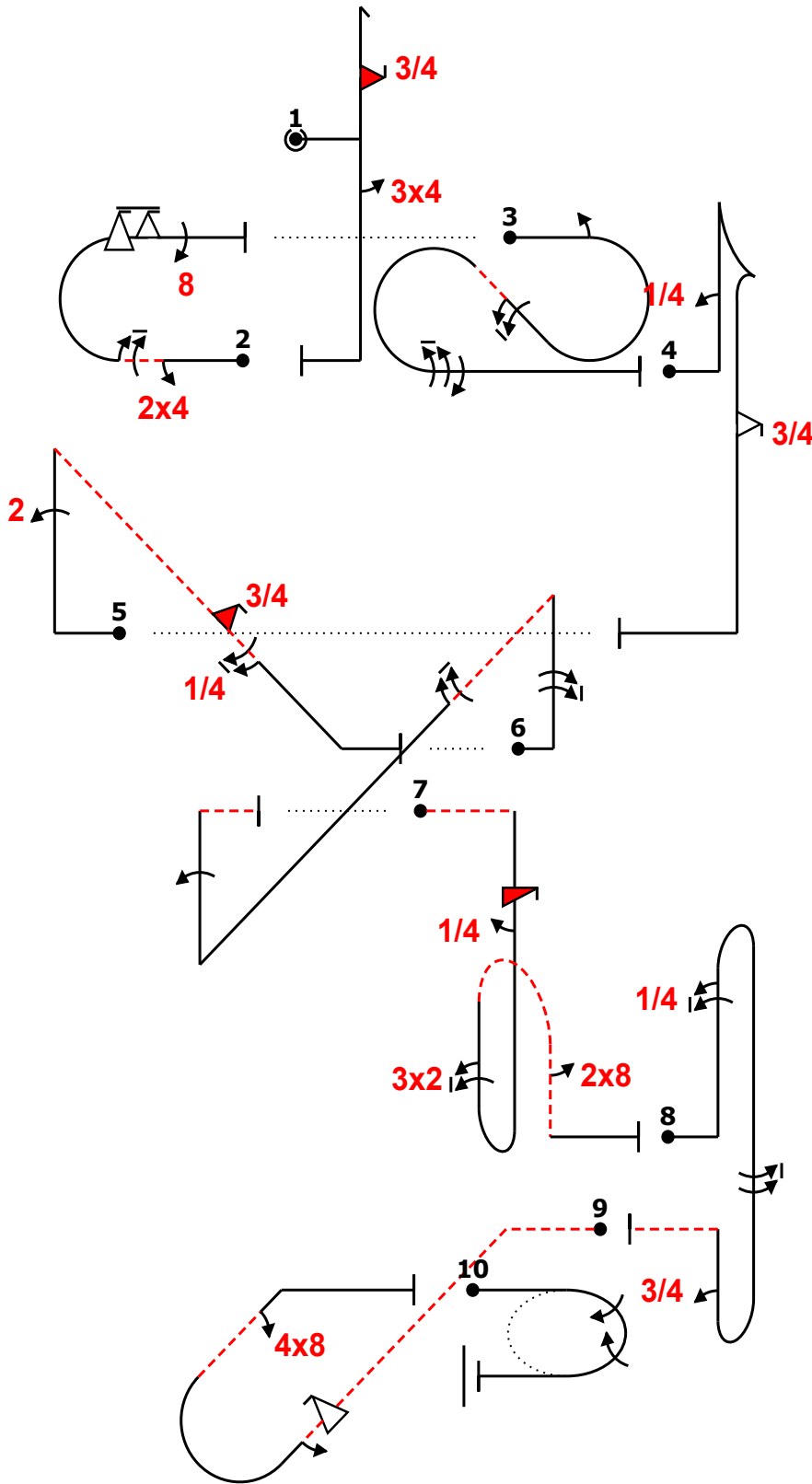

Fig	Grade	Pos	Remarks
1	.		
2	.		
3	.		
4	.		
5	.		
6	.		
7	.		
8	.		
9	.		
10	.		

Positioning 40	.
-------------------	---

Too Low		Trg Violation	
Too High		Wing Rocks	
Interruptions		Disqual Fig	
Insertions		Other(note...)	

Fig 1 A	K	Fig 2 B	K	Fig 3	K	Fig 4	K	Fig 5 D	K	Fig 6	K	Fig 7 E	K	Fig 8	K	Fig 9 C	K	Fig 10	K
5.2.1.1	17	7.2.2.1	6	7.5.5.3	15	6.2.1.1	15	1.2.7.1	13	1.3.11.1	20	8.8.3.4	20	8.8.1.1	18	8.4.16.4	14	2.2.5.1	22
9.10.6.3	19	9.4.3.2	5	9.1.3.2	4	9.1.1.1	6	9.2.1.4	13	9.1.1.8	18	9.12.1.4	7	9.1.1.5	14	9.9.9.4	13		
9.4.5.3	8	9.1.3.6	10	9.1.2.6	12	9.9.5.3	11	9.10.4.3	13	9.1.4.6	10	9.1.5.1	2	9.1.5.8	12	9.1.4.2	4		
		9.9.3.6	14	9.1.3.8	12			9.1.4.5	9	9.1.1.4	12	9.2.1.6	17	9.1.1.3	10	9.8.2.2	9		
		9.8.3.4	15	9.1.3.4	8							9.8.5.1	3						
	44		50		51		32		48		60		49		54		40		22



Figure K
450
Total K
490

Judges Name	
Signature	Number

Flight # 05

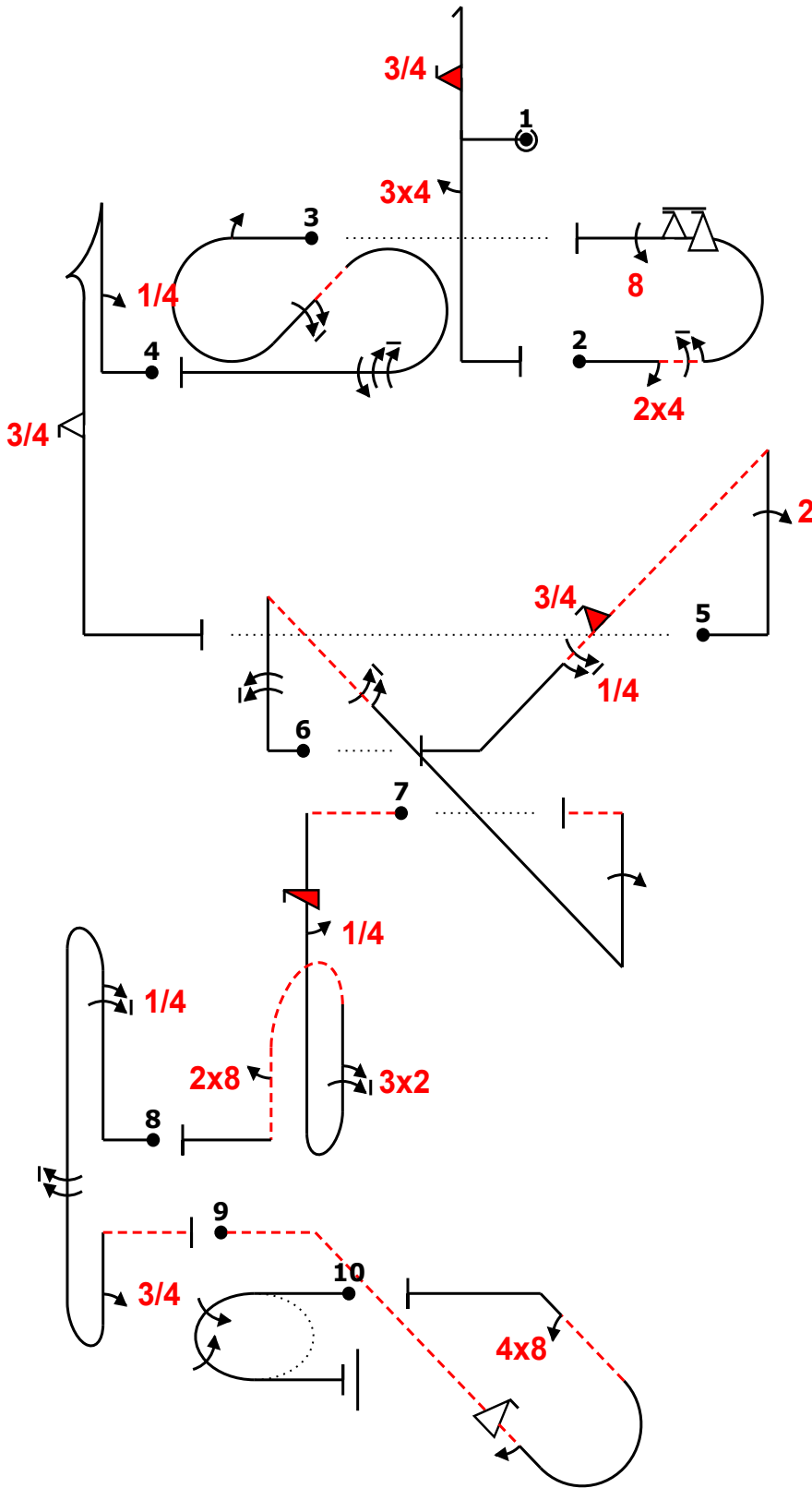
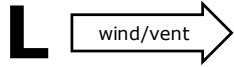

Fig	Grade	Pos	Remarks
1	.		
2	.		
3	.		
4	.		
5	.		
6	.		
7	.		
8	.		
9	.		
10	.		

Positioning 40	.
-------------------	---

Too Low		Trg Violation	
Too High		Wing Rocks	
Interruptions		Disqual Fig	
Insertions		Other(note...)	

Fig 1 A	K	Fig 2 B	K	Fig 3	K	Fig 4	K	Fig 5 D	K	Fig 6	K	Fig 7 E	K	Fig 8	K	Fig 9 C	K	Fig 10	K
5.2.1.1	17	7.2.2.1	6	7.5.5.3	15	6.2.1.1	15	1.2.7.1	13	1.3.11.1	20	8.8.3.4	20	8.8.1.1	18	8.4.16.4	14	2.2.5.1	22
9.10.6.3	19	9.4.3.2	5	9.1.3.2	4	9.1.1.1	6	9.2.1.4	13	9.1.1.8	18	9.12.1.4	7	9.1.1.5	14	9.9.9.4	13		
9.4.5.3	8	9.1.3.6	10	9.1.2.6	12	9.9.5.3	11	9.10.4.3	13	9.1.4.6	10	9.1.5.1	2	9.1.5.8	12	9.1.4.2	4		
		9.9.3.6	14	9.1.3.8	12			9.1.4.5	9	9.1.1.4	12	9.2.1.6	17	9.1.1.3	10	9.8.2.2	9		
		9.8.3.4	15	9.1.3.4	8							9.8.5.1	3						
	44		50		51		32		48		60		49		54		40		22

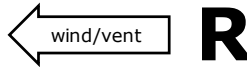

Figure K
450
Total K
490

Judges Name	
Signature	Number

Flight #
06

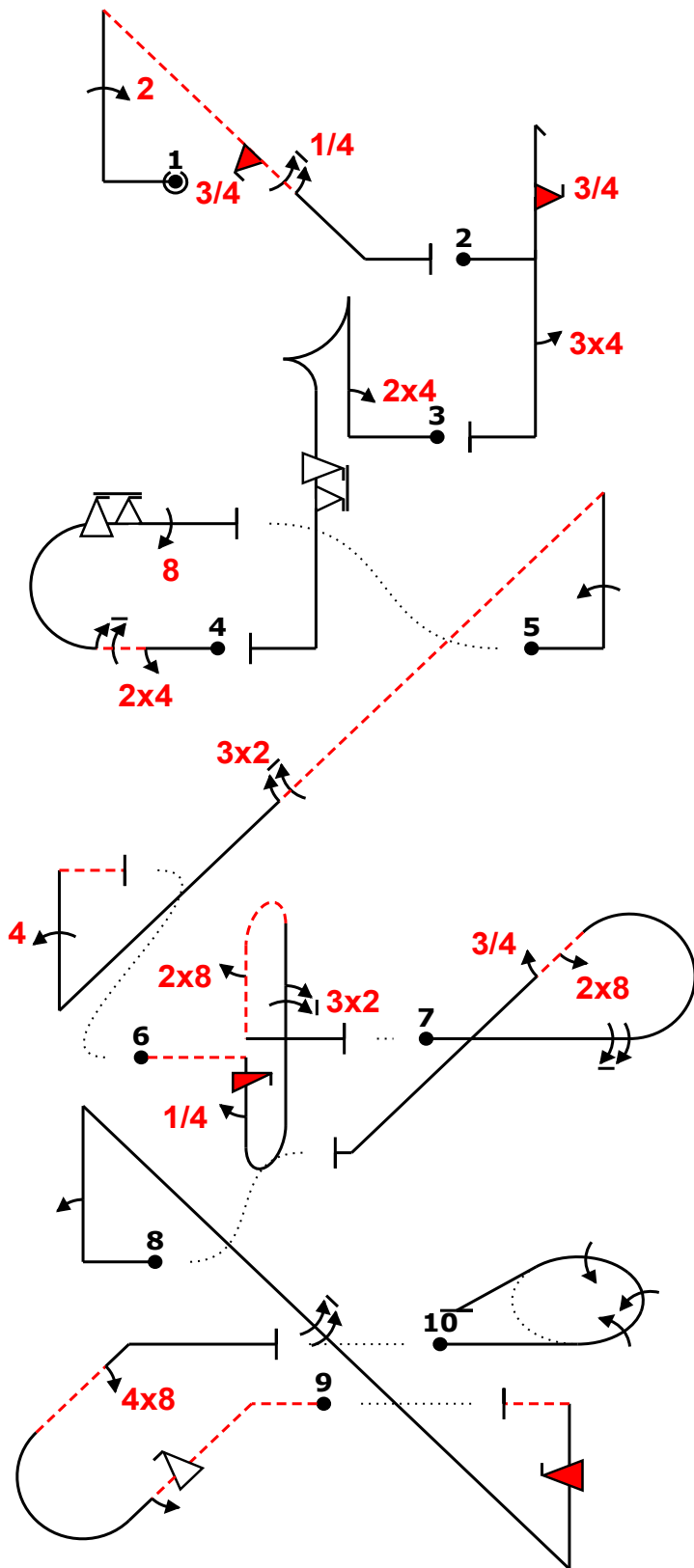

Fig	Grade	Pos	Remarks
1	.		
2	.		
3	.		
4	.		
5	.		
6	.		
7	.		
8	.		
9	.		
10	.		

Positioning
40

Too Low		Trg Violation	
Too High		Wing Rocks	
Interruptions		Disqual Fig	
Insertions		Other(note...)	

Fig 1 D	K	Fig 2 A	K	Fig 3	K	Fig 4 B	K	Fig 5	K	Fig 6 E	K	Fig 7	K	Fig 8	K	Fig 9 C	K	Fig 10	K
1.2.7.1	13	5.2.1.1	17	6.2.1.1	15	7.2.2.1	6	1.3.11.1	20	8.8.3.4	20	8.5.6.1	10	1.3.14.1	22	8.4.16.4	14	2.3.4.1	30
9.2.1.4	13	9.10.6.3	19	9.4.1.2	9	9.4.3.2	5	9.1.1.4	12	9.12.1.4	7	9.1.3.8	12	9.1.1.2	8	9.9.9.4	13		
9.10.4.3	13	9.4.5.3	8	9.9.5.6	14	9.1.3.6	10	9.2.4.6	12	9.1.5.1	2	9.8.4.1	3	9.1.4.8	12	9.1.4.2	4		
9.1.4.5	9					9.9.3.6	14	9.4.1.4	15	9.2.1.6	17	9.1.4.3	6	9.10.6.4	19	9.8.2.2	9		
	48		44		38	9.8.3.4	15		59	9.8.5.1	3								30
							50		49			31		61		40			30



Figure K
450
Total K
490

Judges Name	
Signature	Number

Flight # 06

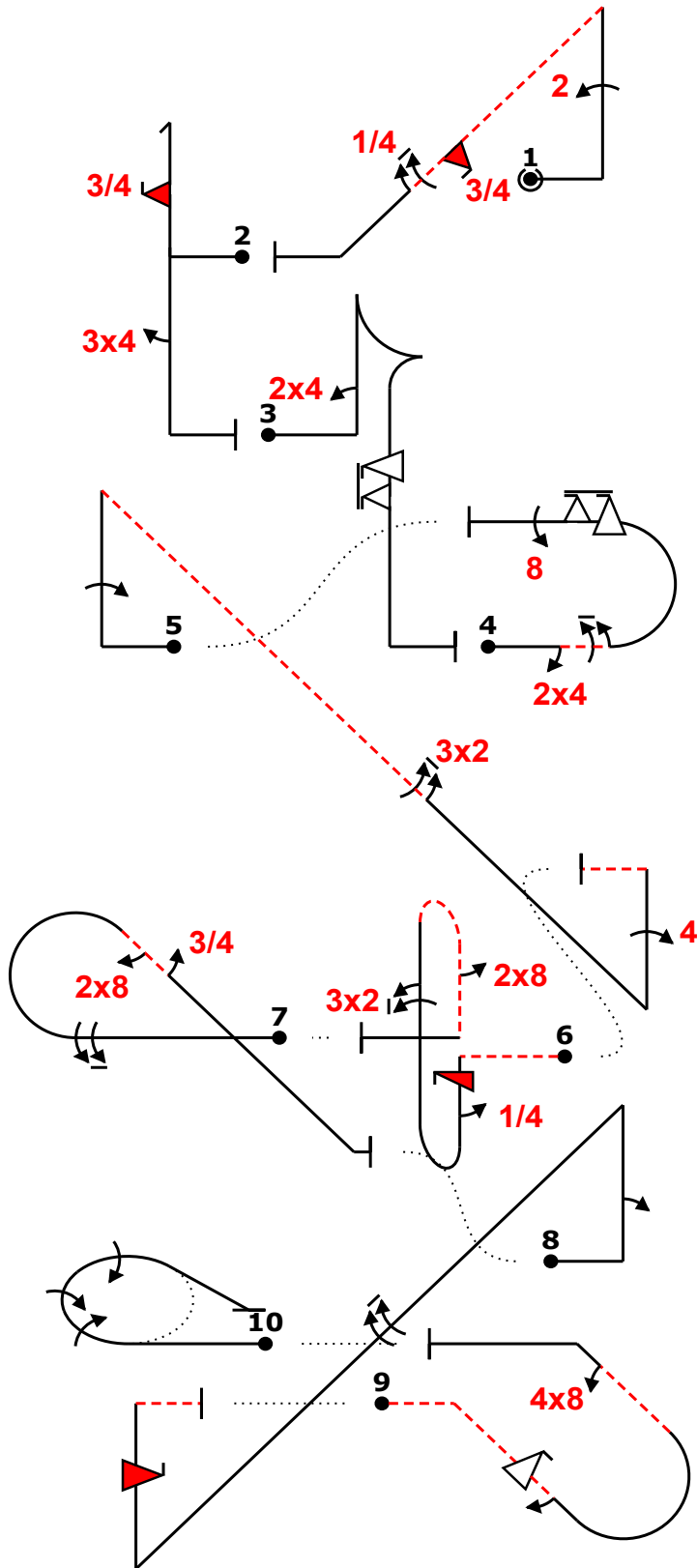
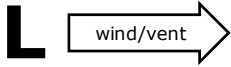

Fig	Grade	Pos	Remarks
1	.		
2	.		
3	.		
4	.		
5	.		
6	.		
7	.		
8	.		
9	.		
10	.		

Positioning 40	.
-------------------	---

Too Low		Trg Violation	
Too High		Wing Rocks	
Interruptions		Disqual Fig	
Insertions		Other(note...)	

Fig 1 D	K	Fig 2 A	K	Fig 3	K	Fig 4 B	K	Fig 5	K	Fig 6 E	K	Fig 7	K	Fig 8	K	Fig 9 C	K	Fig 10	K
1.2.7.1	13	5.2.1.1	17	6.2.1.1	15	7.2.2.1	6	1.3.11.1	20	8.8.3.4	20	8.5.6.1	10	1.3.14.1	22	8.4.16.4	14	2.3.4.1	30
9.2.1.4	13	9.10.6.3	19	9.4.1.2	9	9.4.3.2	5	9.1.1.4	12	9.12.1.4	7	9.1.3.8	12	9.1.1.2	8	9.9.9.4	13		
9.10.4.3	13	9.4.5.3	8	9.9.5.6	14	9.1.3.6	10	9.2.4.6	12	9.1.5.1	2	9.8.4.1	3	9.1.4.8	12	9.1.4.2	4		
9.1.4.5	9					9.9.3.6	14	9.4.1.4	15	9.2.1.6	17	9.1.4.3	6	9.10.6.4	19	9.8.2.2	9		
						9.8.3.4	15			9.8.5.1	3								
	48		44		38		50		59		49		31		61		40		30

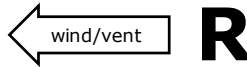

Figure K
450
Total K
490

Judges Name	
Signature	Number

Flight # 07

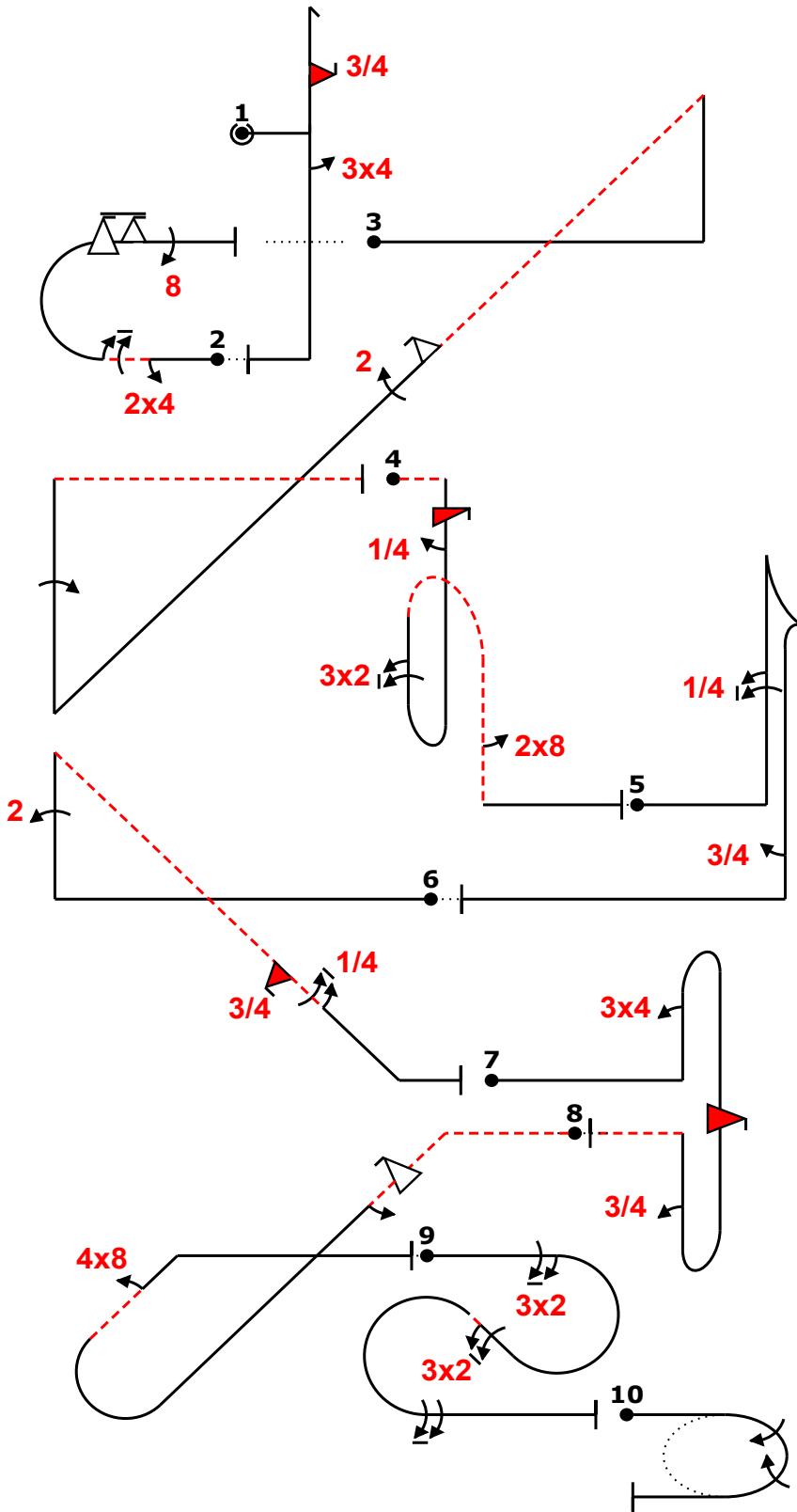

Fig	Grade	Pos	Remarks
1	.		
2	.		
3	.		
4	.		
5	.		
6	.		
7	.		
8	.		
9	.		
10	.		

Positioning 40	.
--------------------------	---

Too Low		Trg Violation	
Too High		Wing Rocks	
Interruptions		Disqual Fig	
Insertions		Other(note...)	

Fig 1 A	K	Fig 2 B	K	Fig 3	K	Fig 4 E	K	Fig 5	K	Fig 6 D	K	Fig 7	K	Fig 8 C	K	Fig 9	K	Fig 10	K
5.2.1.1	17	7.2.2.1	6	1.3.11.1	20	8.8.3.4	20	6.2.1.1	15	1.2.7.1	13	8.8.1.1	18	8.4.16.4	14	7.5.5.3	15	2.2.5.1	22
9.10.6.3	19	9.4.3.2	5	9.9.9.2	13	9.12.1.4	7	9.1.1.5	14	9.2.1.4	13	9.4.1.3	12	9.9.9.4	13	9.2.3.6	12		
9.4.5.3	8	9.1.3.6	10	9.2.4.4	9	9.1.5.1	2	9.1.5.3	6	9.10.4.3	13	9.10.10.4	15	9.1.4.2	4	9.2.2.6	14		
		9.9.3.6	14	9.1.1.4	12	9.2.1.6	17			9.1.4.5	9	9.1.1.3	10	9.8.2.2	9	9.1.3.8	12		
		9.8.3.4	15			9.8.5.1	3												
	44		50		54		49		35		48		55		40		53		22



CIVA Unlimited SEP 2023
Free Known EAC 23 PAVULLO, ITA

Figure K
450
Total K
490

Judges Name	
Signature	Number

Flight #
07

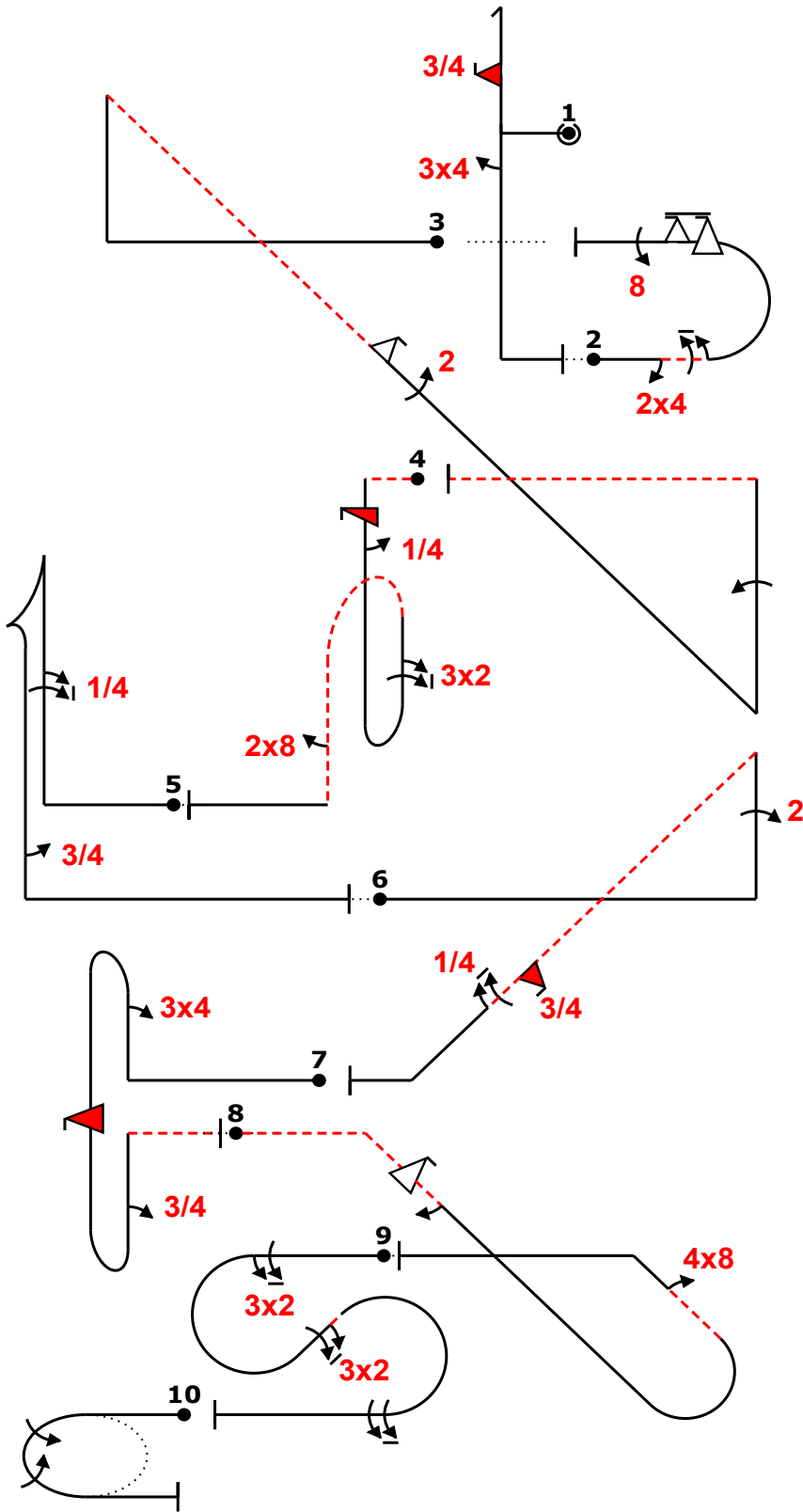
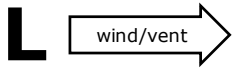

Fig	Grade	Pos	Remarks
1	.		
2	.		
3	.		
4	.		
5	.		
6	.		
7	.		
8	.		
9	.		
10	.		

Positioning
40

Too Low		Trg Violation	
Too High		Wing Rocks	
Interruptions		Disqual Fig	
Insertions		Other(note...)	

Fig 1 A	K	Fig 2 B	K	Fig 3	K	Fig 4 E	K	Fig 5	K	Fig 6 D	K	Fig 7	K	Fig 8 C	K	Fig 9	K	Fig 10	K
5.2.1.1	17	7.2.2.1	6	1.3.11.1	20	8.8.3.4	20	6.2.1.1	15	1.2.7.1	13	8.8.1.1	18	8.4.16.4	14	7.5.5.3	15	2.2.5.1	22
9.10.6.3	19	9.4.3.2	5	9.9.9.2	13	9.12.1.4	7	9.1.1.5	14	9.2.1.4	13	9.4.1.3	12	9.9.9.4	13	9.2.3.6	12		
9.4.5.3	8	9.1.3.6	10	9.2.4.4	9	9.1.5.1	2	9.1.5.3	6	9.10.4.3	13	9.10.10.4	15	9.1.4.2	4	9.2.2.6	14		
		9.9.3.6	14	9.1.1.4	12	9.2.1.6	17			9.1.4.5	9	9.1.1.3	10	9.8.2.2	9	9.1.3.8	12		
		9.8.3.4	15			9.8.5.1	3												
	44		50		54		49		35		48		55		40		53		22

Pilot: PEKAR ANTOINE

A/C: EXTRA 330 SC F-HODV Team: FRA

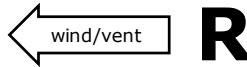

Figure K
450
Total K
490

Judges Name	
Signature	Number

Flight # 08

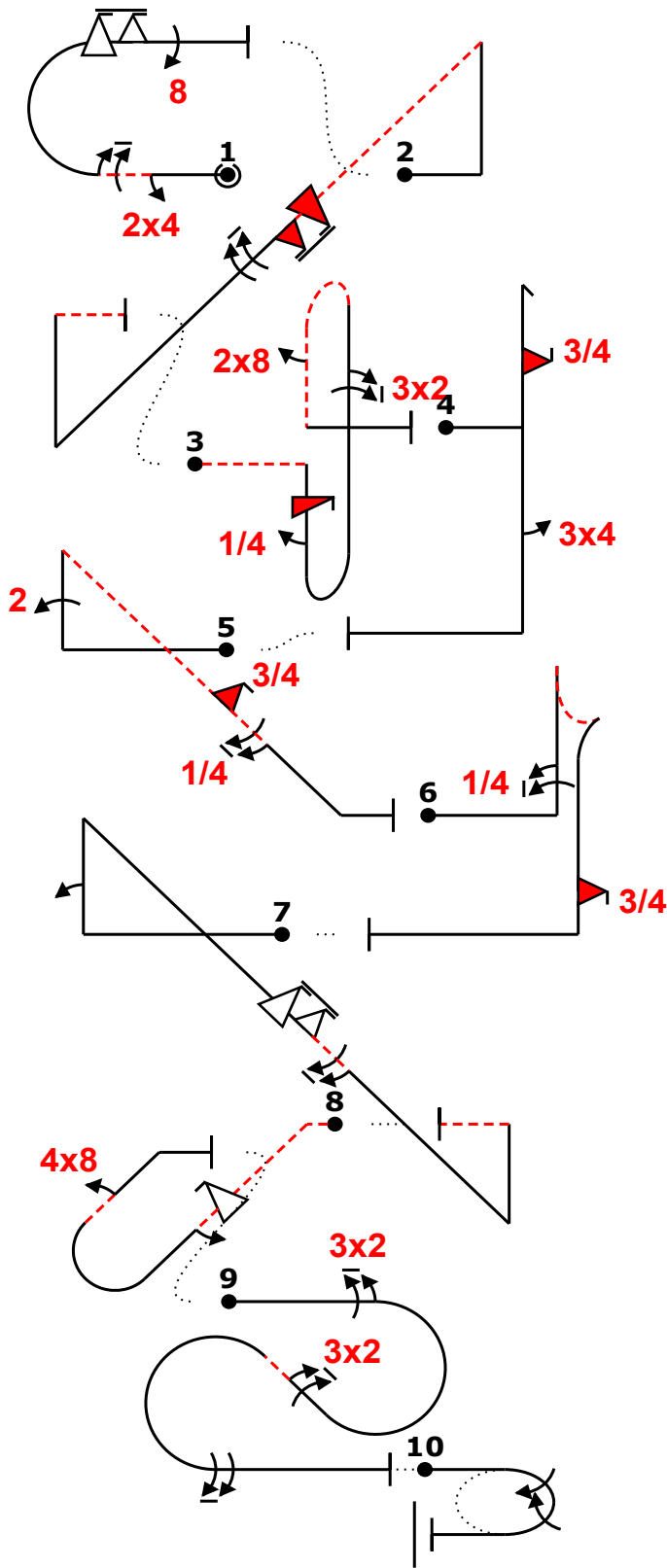

Fig	Grade	Pos	Remarks
1	.		
2	.		
3	.		
4	.		
5	.		
6	.		
7	.		
8	.		
9	.		
10	.		

Positioning 40	.
--------------------------	---

Too Low		Trg Violation	
Too High		Wing Rocks	
Interruptions		Disqual Fig	
Insertions		Other(note...)	

Fig 1 B	K	Fig 2	K	Fig 3 E	K	Fig 4 A	K	Fig 5 D	K	Fig 6	K	Fig 7	K	Fig 8 C	K	Fig 9	K	Fig 10	K
7.2.2.1	6	1.3.11.1	20	8.8.3.4	20	5.2.1.1	17	1.2.7.1	13	6.2.2.1	15	1.3.14.1	22	8.4.16.4	14	7.5.5.3	15	2.2.5.1	22
9.4.3.2	5	9.10.4.6	16	9.12.1.4	7	9.10.6.3	19	9.2.1.4	13	9.1.1.5	14	9.1.1.2	8	9.9.9.4	13	9.2.3.6	12		
9.1.3.6	10	9.1.4.8	12	9.1.5.1	2	9.4.5.3	8	9.10.4.3	13	9.10.5.3	13	9.9.4.6	14	9.1.4.2	4	9.2.2.6	14		
9.9.3.6	14			9.2.1.6	17			9.1.4.5	9			9.1.4.6	10	9.8.2.2	9	9.1.3.8	12		
9.8.3.4	15			9.8.5.1	3														
	50		48		49		44		48		42		54		40		53		22



Figure K
450
Total K
490

Judges Name	
Signature	Number

Flight #
08

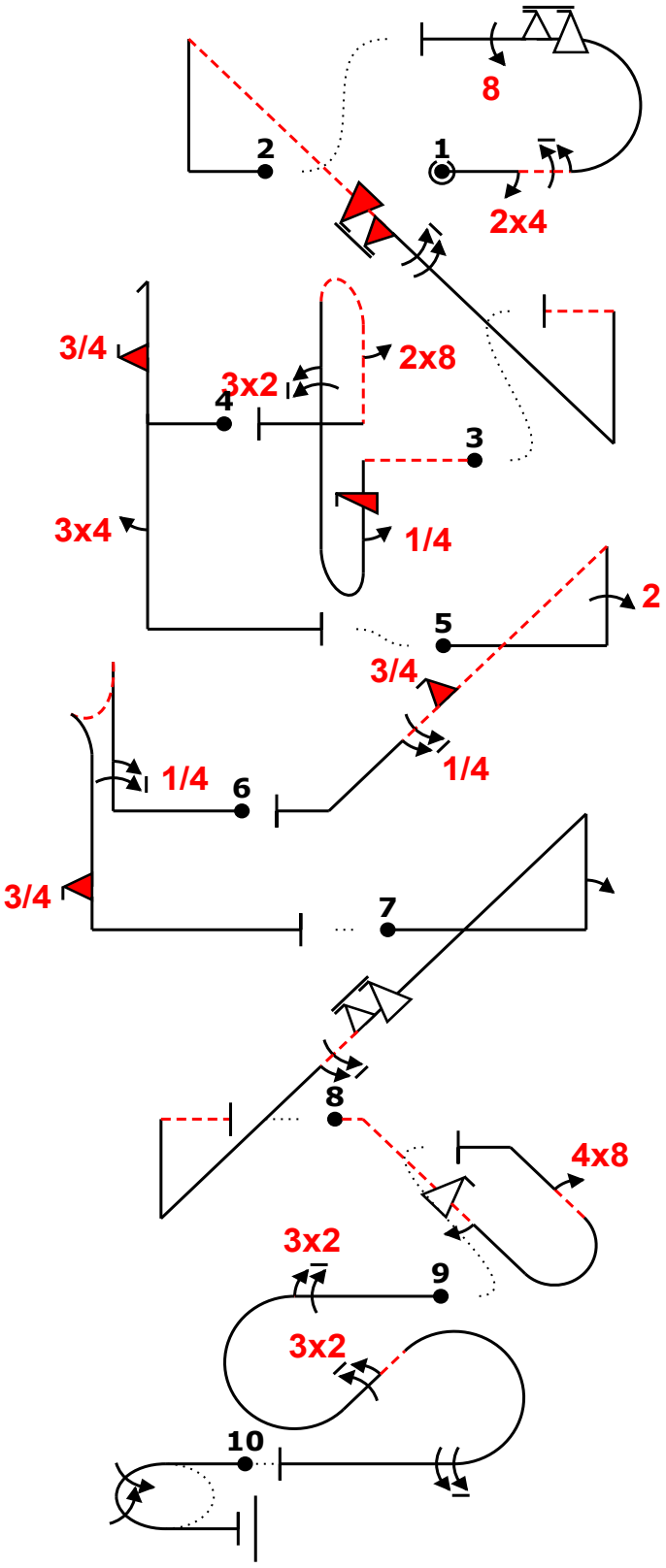
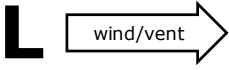

Fig	Grade	Pos	Remarks
1	.		
2	.		
3	.		
4	.		
5	.		
6	.		
7	.		
8	.		
9	.		
10	.		

Positioning
40 .

Too Low		Trg Violation	
Too High		Wing Rocks	
Interruptions		Disqual Fig	
Insertions		Other(note...)	

Fig 1 B	K	Fig 2	K	Fig 3 E	K	Fig 4 A	K	Fig 5 D	K	Fig 6	K	Fig 7	K	Fig 8 C	K	Fig 9	K	Fig 10	K
7.2.2.1	6	1.3.11.1	20	8.8.3.4	20	5.2.1.1	17	1.2.7.1	13	6.2.2.1	15	1.3.14.1	22	8.4.16.4	14	7.5.5.3	15	2.2.5.1	22
9.4.3.2	5	9.10.4.6	16	9.12.1.4	7	9.10.6.3	19	9.2.1.4	13	9.1.1.5	14	9.1.1.2	8	9.9.9.4	13	9.2.3.6	12		
9.1.3.6	10	9.1.4.8	12	9.1.5.1	2	9.4.5.3	8	9.10.4.3	13	9.10.5.3	13	9.9.4.6	14	9.1.4.2	4	9.2.2.6	14		
9.9.3.6	14			9.2.1.6	17			9.1.4.5	9			9.1.4.6	10	9.8.2.2	9	9.1.3.8	12		
9.8.3.4	15			9.8.5.1	3														
	50		48		49		44		48		42		54		40		53		22

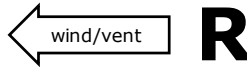

Figure K
450
Total K
490

Judges Name	
Signature	Number

Flight # 09

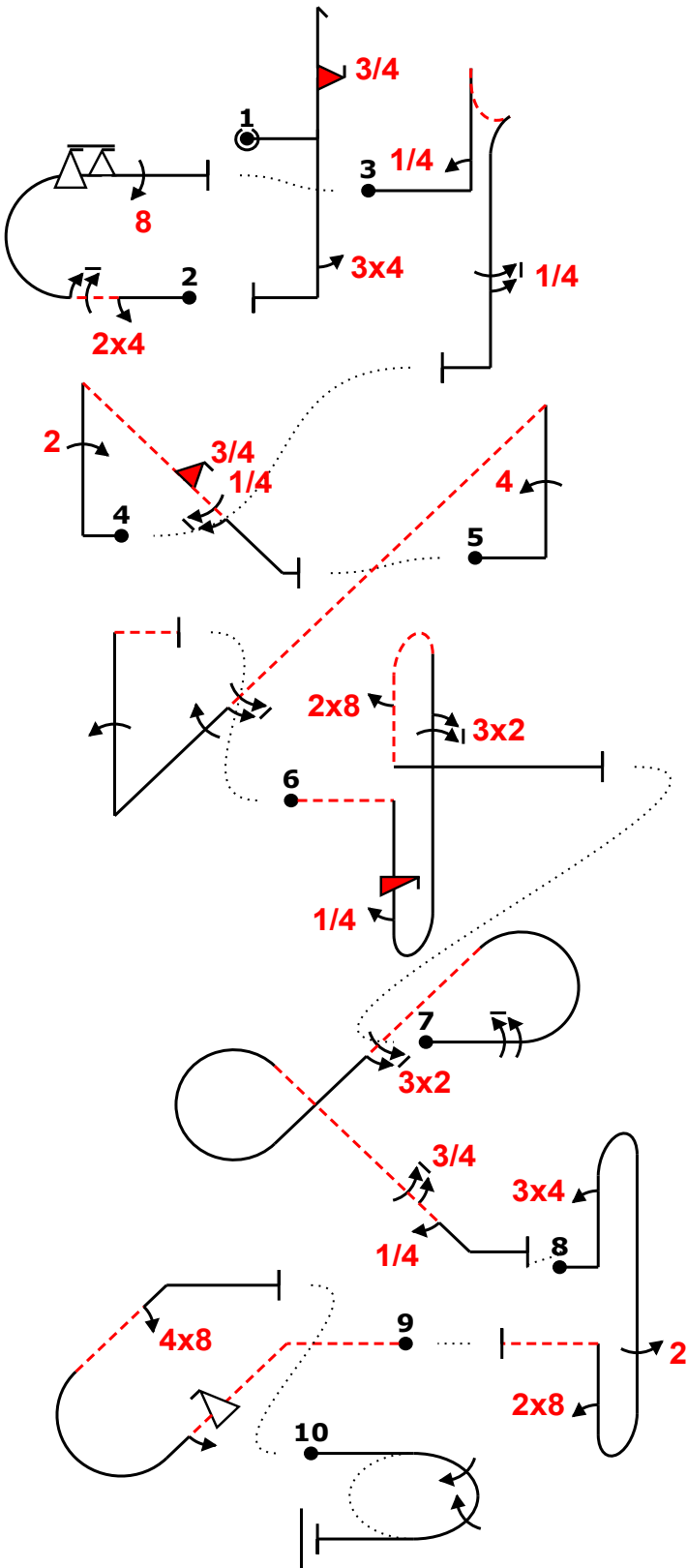

Fig	Grade	Pos	Remarks
1	.		
2	.		
3	.		
4	.		
5	.		
6	.		
7	.		
8	.		
9	.		
10	.		

Positioning 40	.
--------------------------	---

Too Low		Trg Violation	
Too High		Wing Rocks	
Interruptions		Disqual Fig	
Insertions		Other(note...)	

Fig 1 A	K	Fig 2 B	K	Fig 3	K	Fig 4 D	K	Fig 5	K	Fig 6 E	K	Fig 7	K	Fig 8	K	Fig 9 C	K	Fig 10	K
5.2.1.1	17	7.2.2.1	6	6.2.2.1	15	1.2.7.1	13	1.3.11.1	20	8.8.3.4	20	7.8.4.1	19	8.8.1.1	18	8.4.16.4	14	2.2.5.1	22
9.10.6.3	19	9.4.3.2	5	9.1.1.1	6	9.2.1.4	13	9.4.1.4	15	9.12.1.4	7	9.1.3.8	12	9.4.1.3	12	9.9.9.4	13		
9.4.5.3	8	9.1.3.6	10	9.1.5.5	9	9.10.4.3	13	9.1.4.6	10	9.1.5.1	2	9.2.4.6	12	9.2.5.4	9	9.1.4.2	4		
		9.9.3.6	14			9.1.4.5	9	9.1.4.4	8	9.2.1.6	17	9.1.4.7	11	9.8.1.1	7	9.8.2.2	9		
		9.8.3.4	15			9.1.1.4	12	9.1.1.4	12	9.8.5.1	3	9.1.4.1	2						
	44		50		30		48		65		49		56		46		40		22



CIVA Unlimited SEP 2023
Free Known EAC 23 PAVULLO, ITA

Figure K
450
Total K
490

Judges Name	
Signature	Number

Flight #
09

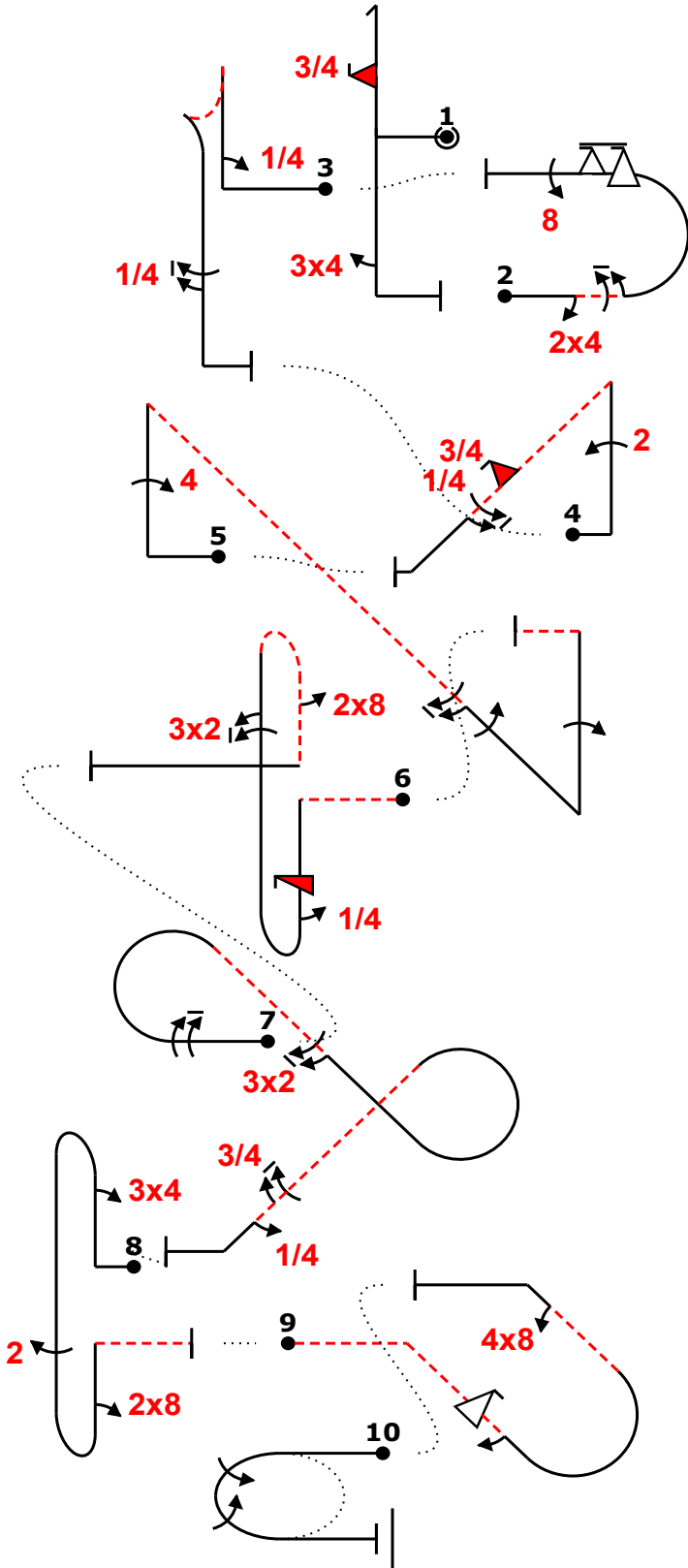
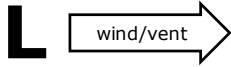

Fig	Grade	Pos	Remarks
1	.		
2	.		
3	.		
4	.		
5	.		
6	.		
7	.		
8	.		
9	.		
10	.		

Positioning
40 .

Too Low		Trg Violation	
Too High		Wing Rocks	
Interruptions		Disqual Fig	
Insertions		Other(note...)	

Fig 1 A	K	Fig 2 B	K	Fig 3	K	Fig 4 D	K	Fig 5	K	Fig 6 E	K	Fig 7	K	Fig 8	K	Fig 9 C	K	Fig 10	K
5.2.1.1	17	7.2.2.1	6	6.2.2.1	15	1.2.7.1	13	1.3.11.1	20	8.8.3.4	20	7.8.4.1	19	8.8.1.1	18	8.4.16.4	14	2.2.5.1	22
9.10.6.3	19	9.4.3.2	5	9.1.1.1	6	9.2.1.4	13	9.4.1.4	15	9.12.1.4	7	9.1.3.8	12	9.4.1.3	12	9.9.9.4	13		
9.4.5.3	8	9.1.3.6	10	9.1.5.5	9	9.10.4.3	13	9.1.4.6	10	9.1.5.1	2	9.2.4.6	12	9.2.5.4	9	9.1.4.2	4		
		9.9.3.6	14			9.1.4.5	9	9.1.4.4	8	9.2.1.6	17	9.1.4.7	11	9.8.1.1	7	9.8.2.2	9		
		9.8.3.4	15			9.1.1.4	12	9.1.1.4	12	9.8.5.1	3	9.1.4.1	2						
	44		50		30		48		65		49		56		46		40		22

Pilot: PARIZEK LUKAS

A/C: EXTRA 330 SC OK-LPJ Team: CZE



Figure K
450
Total K
490

Judges Name	
Signature	Number

Flight # 10

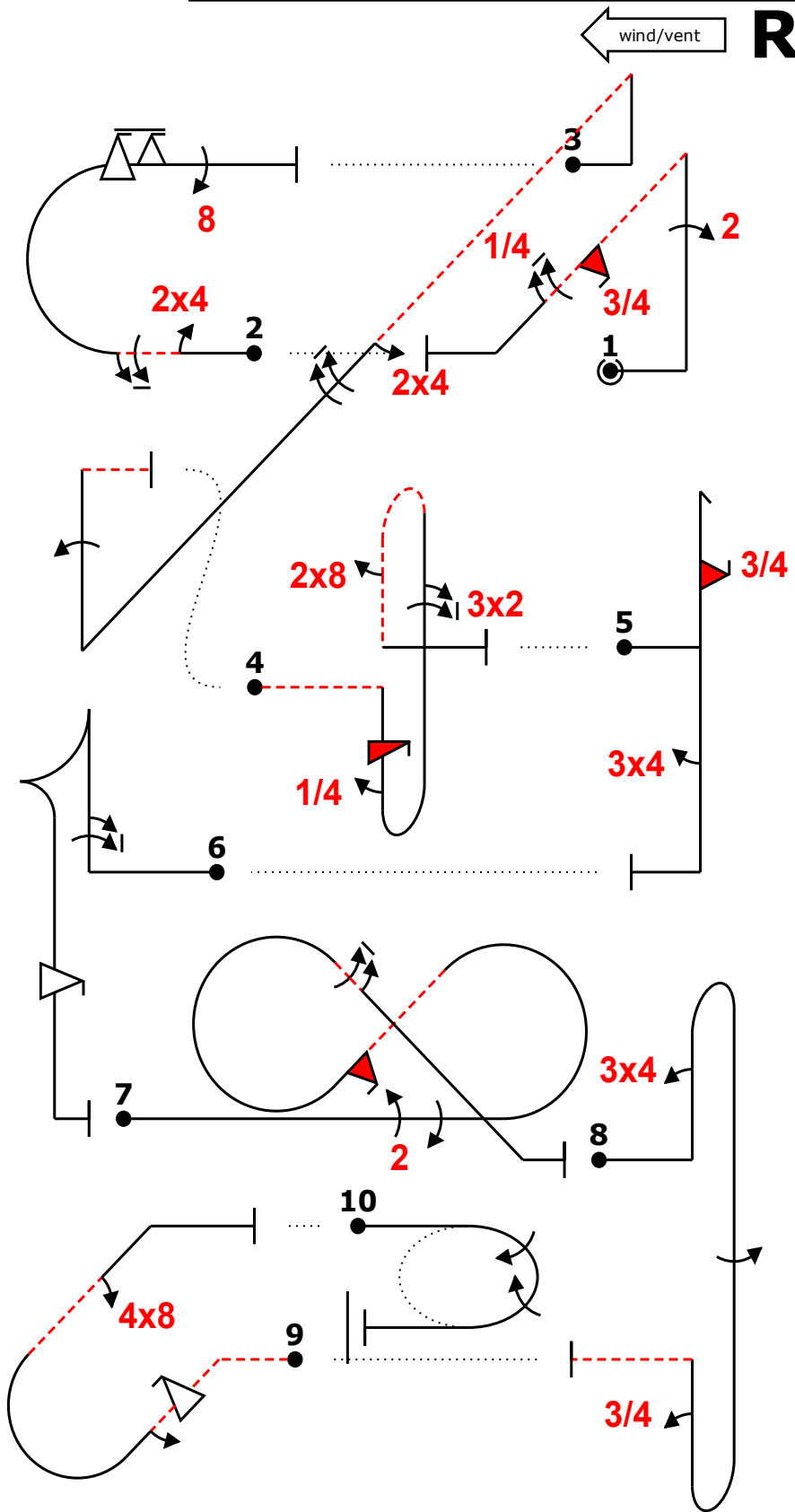

Fig	Grade	Pos	Remarks
1	.		
2	.		
3	.		
4	.		
5	.		
6	.		
7	.		
8	.		
9	.		
10	.		

Positioning 40	.
--------------------------	---

Too Low		Trg Violation	
Too High		Wing Rocks	
Interruptions		Disqual Fig	
Insertions		Other(note...)	

Fig 1 D	K	Fig 2 B	K	Fig 3	K	Fig 4 E	K	Fig 5 A	K	Fig 6	K	Fig 7	K	Fig 8	K	Fig 9 C	K	Fig 10	K
1.2.7.1	13	7.2.2.1	6	1.3.11.1	20	8.8.3.4	20	5.2.1.1	17	6.2.1.1	15	7.8.4.1	19	8.8.1.1	18	8.4.16.4	14	2.2.5.1	22
9.2.1.4	13	9.4.3.2	5	9.4.4.2	5	9.12.1.4	7	9.10.6.3	19	9.1.1.6	15	9.2.3.4	9	9.4.1.3	12	9.9.9.4	13		
9.10.4.3	13	9.1.3.6	10	9.1.4.8	12	9.1.5.1	2	9.4.5.3	8	9.9.5.4	11	9.1.3.4	8	9.1.5.4	8	9.1.4.2	4		
9.1.4.5	9	9.9.3.6	14	9.1.1.4	12	9.2.1.6	17					9.10.4.2	13	9.1.1.3	10	9.8.2.2	9		
		9.8.3.4	15			9.8.5.1	3					9.1.4.6	10						
	48		50		49		49		44		41		59		48		40		22



Figure K
450
Total K
490

Judges Name	
Signature	Number

Flight #
10

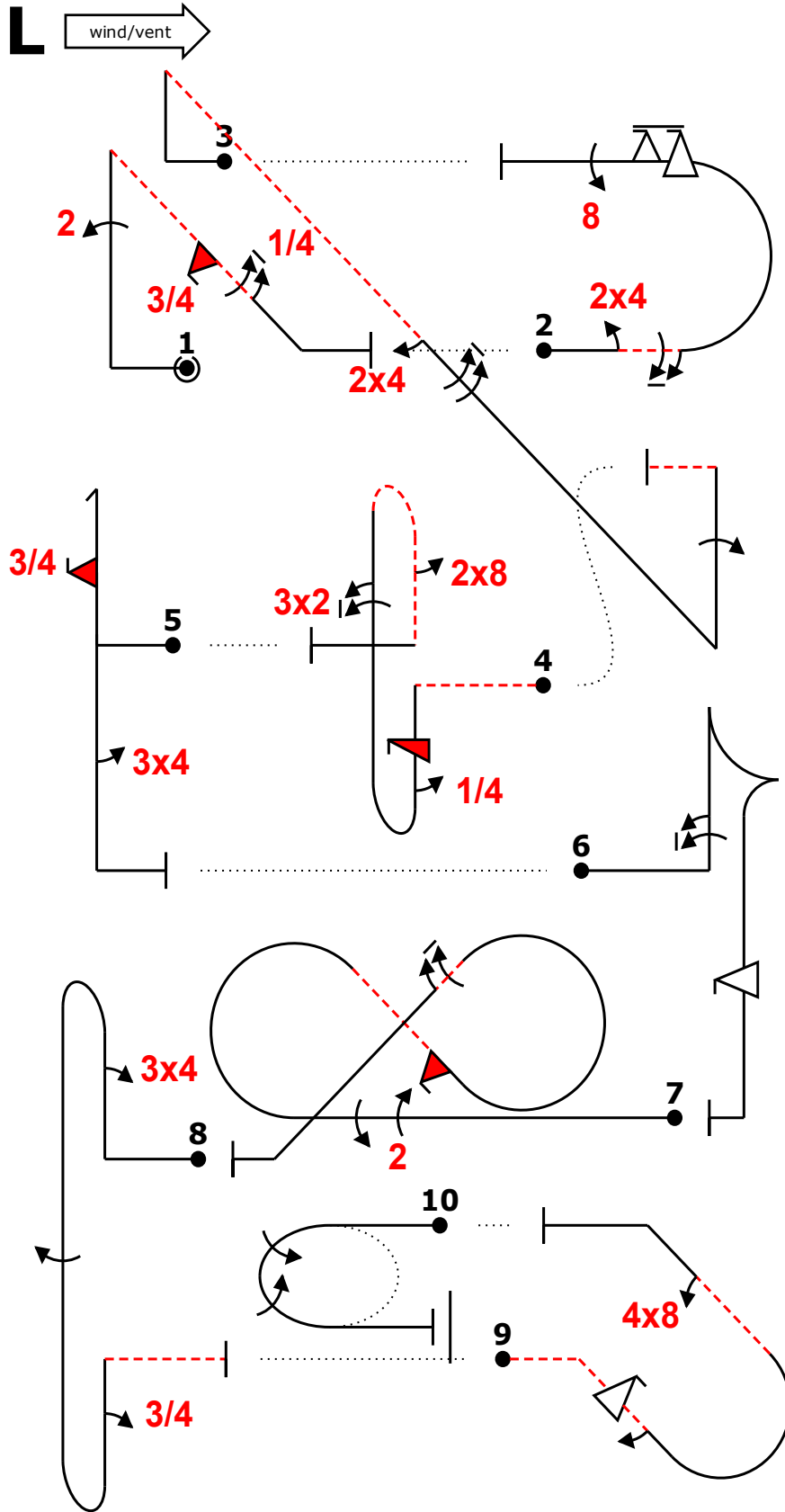

Fig	Grade	Pos	Remarks
1	.		
2	.		
3	.		
4	.		
5	.		
6	.		
7	.		
8	.		
9	.		
10	.		

Positioning
40

Too Low		Trg Violation	
Too High		Wing Rocks	
Interruptions		Disqual Fig	
Insertions		Other(note...)	

Fig 1 D	K	Fig 2 B	K	Fig 3	K	Fig 4 E	K	Fig 5 A	K	Fig 6	K	Fig 7	K	Fig 8	K	Fig 9 C	K	Fig 10	K
1.2.7.1	13	7.2.2.1	6	1.3.11.1	20	8.8.3.4	20	5.2.1.1	17	6.2.1.1	15	7.8.4.1	19	8.8.1.1	18	8.4.16.4	14	2.2.5.1	22
9.2.1.4	13	9.4.3.2	5	9.4.4.2	5	9.12.1.4	7	9.10.6.3	19	9.1.1.6	15	9.2.3.4	9	9.4.1.3	12	9.9.9.4	13		
9.10.4.3	13	9.1.3.6	10	9.1.4.8	12	9.1.5.1	2	9.4.5.3	8	9.9.5.4	11	9.1.3.4	8	9.1.5.4	8	9.1.4.2	4		
9.1.4.5	9	9.9.3.6	14	9.1.1.4	12	9.2.1.6	17					9.10.4.2	13	9.1.1.3	10	9.8.2.2	9		
		9.8.3.4	15			9.8.5.1	3					9.1.4.6	10						
	48		50		49		49		44		41		59		48		40		22



CIVA Unlimited SEP 2023
Free Known EAC 23 PAVULLO, ITA

wind/vent **R**

Figure K
450
Total K
490

Judges Name	
Signature	Number

Flight #
11

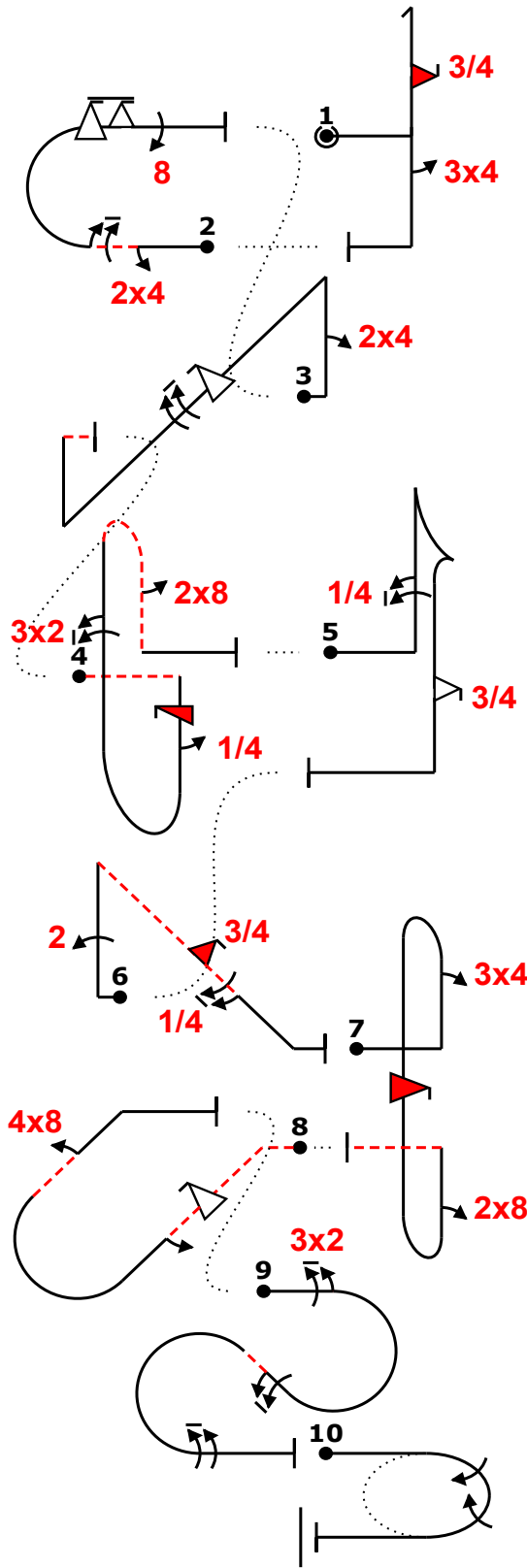

Fig	Grade	Pos	Remarks
1	.		
2	.		
3	.		
4	.		
5	.		
6	.		
7	.		
8	.		
9	.		
10	.		

Positioning
40

Too Low		Trg Violation	
Too High		Wing Rocks	
Interruptions		Disqual Fig	
Insertions		Other(note...)	

Fig 1 A	K	Fig 2 B	K	Fig 3	K	Fig 4 E	K	Fig 5	K	Fig 6 D	K	Fig 7	K	Fig 8 C	K	Fig 9	K	Fig 10	K
5.2.1.1	17	7.2.2.1	6	1.3.14.1	22	8.8.3.4	20	6.2.1.1	15	1.2.7.1	13	8.8.1.1	18	8.4.16.4	14	7.5.5.3	15	2.2.5.1	22
9.10.6.3	19	9.4.3.2	5	9.4.1.2	9	9.12.1.4	7	9.1.1.5	14	9.2.1.4	13	9.4.1.3	12	9.9.9.4	13	9.2.3.6	12		
9.4.5.3	8	9.1.3.6	10	9.9.4.4	11	9.1.5.1	2	9.9.5.3	11	9.10.4.3	13	9.10.10.4	15	9.1.4.2	4	9.1.2.6	12		
		9.9.3.6	14	9.1.4.8	12	9.2.1.6	17			9.1.4.5	9	9.8.1.1	7	9.8.2.2	9	9.1.3.8	12		
		9.8.3.4	15			9.8.5.1	3												
	44		50		54		49		40		48		52		40		51		22

Pilot: CALMES GUILLAUME

A/C: EXTRA 330 SC F-HODV Team: FRA



Figure K
450
Total K
490

Judges Name	
Signature	Number

Flight # 11

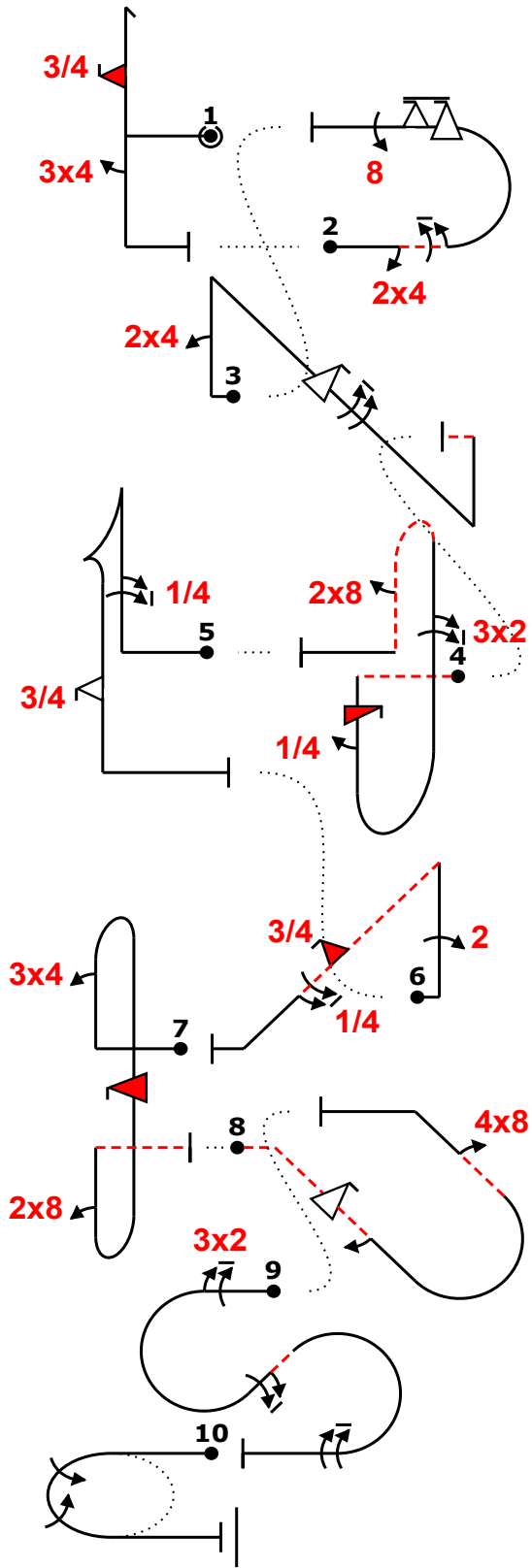
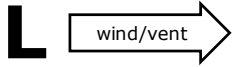

Fig	Grade	Pos	Remarks
1	.		
2	.		
3	.		
4	.		
5	.		
6	.		
7	.		
8	.		
9	.		
10	.		

Positioning 40	.
--------------------------	---

Too Low		Trg Violation	
Too High		Wing Rocks	
Interruptions		Disqual Fig	
Insertions		Other(note...)	

Fig 1 A	K	Fig 2 B	K	Fig 3	K	Fig 4 E	K	Fig 5	K	Fig 6 D	K	Fig 7	K	Fig 8 C	K	Fig 9	K	Fig 10	K
5.2.1.1	17	7.2.2.1	6	1.3.14.1	22	8.8.3.4	20	6.2.1.1	15	1.2.7.1	13	8.8.1.1	18	8.4.16.4	14	7.5.5.3	15	2.2.5.1	22
9.10.6.3	19	9.4.3.2	5	9.4.1.2	9	9.12.1.4	7	9.1.1.5	14	9.2.1.4	13	9.4.1.3	12	9.9.9.4	13	9.2.3.6	12		
9.4.5.3	8	9.1.3.6	10	9.9.4.4	11	9.1.5.1	2	9.9.5.3	11	9.10.4.3	13	9.10.10.4	15	9.1.4.2	4	9.1.2.6	12		
		9.9.3.6	14	9.1.4.8	12	9.2.1.6	17			9.1.4.5	9	9.8.1.1	7	9.8.2.2	9	9.1.3.8	12		
		9.8.3.4	15			9.8.5.1	3												
	44		50		54		49		40		48		52		40		51		22



Figure K
450
Total K
490

Judges Name	
Signature	Number

Flight # 12

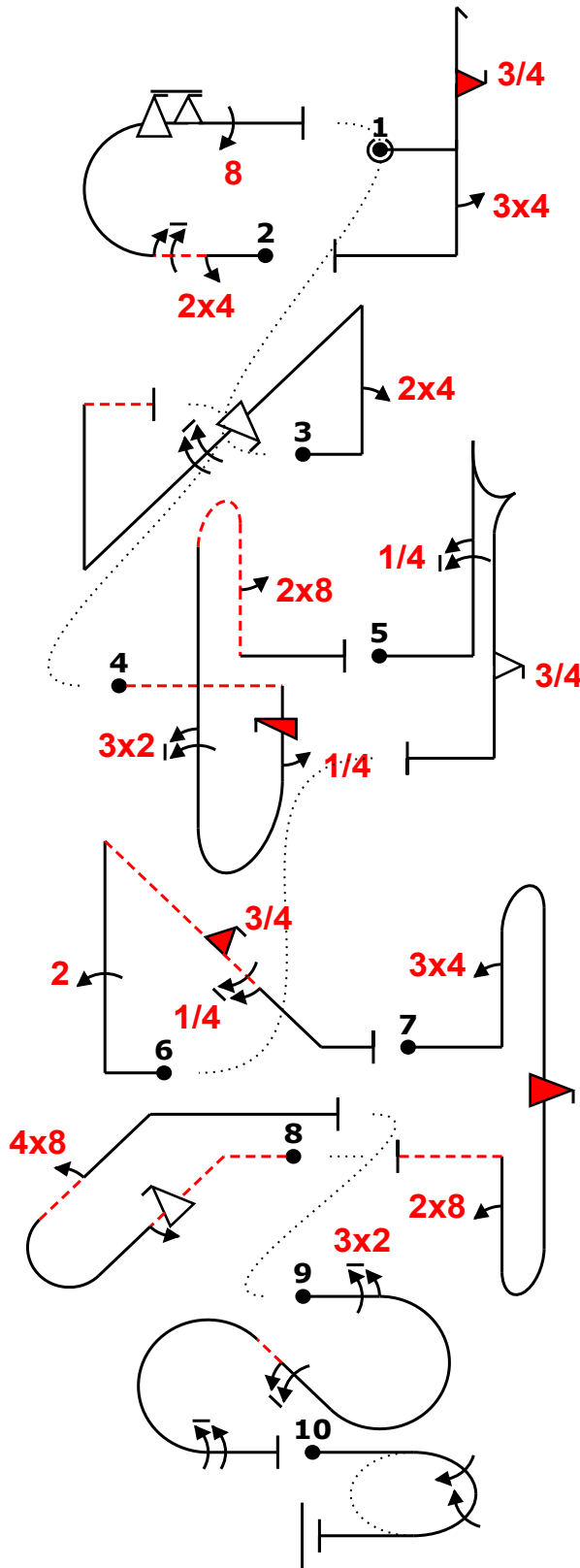
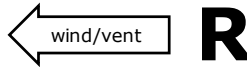

Fig	Grade	Pos	Remarks
1	.		
2	.		
3	.		
4	.		
5	.		
6	.		
7	.		
8	.		
9	.		
10	.		

Positioning 40	.
--------------------------	---

Too Low		Trg Violation	
Too High		Wing Rocks	
Interruptions		Disqual Fig	
Insertions		Other(note...)	

Fig 1 A	K	Fig 2 B	K	Fig 3	K	Fig 4 E	K	Fig 5	K	Fig 6 D	K	Fig 7	K	Fig 8 C	K	Fig 9	K	Fig 10	K
5.2.1.1	17	7.2.2.1	6	1.3.14.1	22	8.8.3.4	20	6.2.1.1	15	1.2.7.1	13	8.8.1.1	18	8.4.16.4	14	7.5.5.3	15	2.2.5.1	22
9.10.6.3	19	9.4.3.2	5	9.4.1.2	9	9.12.1.4	7	9.1.1.5	14	9.2.1.4	13	9.4.1.3	12	9.9.9.4	13	9.2.3.6	12		
9.4.5.3	8	9.1.3.6	10	9.9.4.4	11	9.1.5.1	2	9.9.5.3	11	9.10.4.3	13	9.10.10.4	15	9.1.4.2	4	9.1.2.6	12		
		9.9.3.6	14	9.1.4.8	12	9.2.1.6	17			9.1.4.5	9	9.8.1.1	7	9.8.2.2	9	9.1.3.8	12		
		9.8.3.4	15			9.8.5.1	3												
	44		50		54		49		40		48		52		40		51		22



Figure K
450
Total K
490

Judges Name	
Signature	Number

Flight #
12

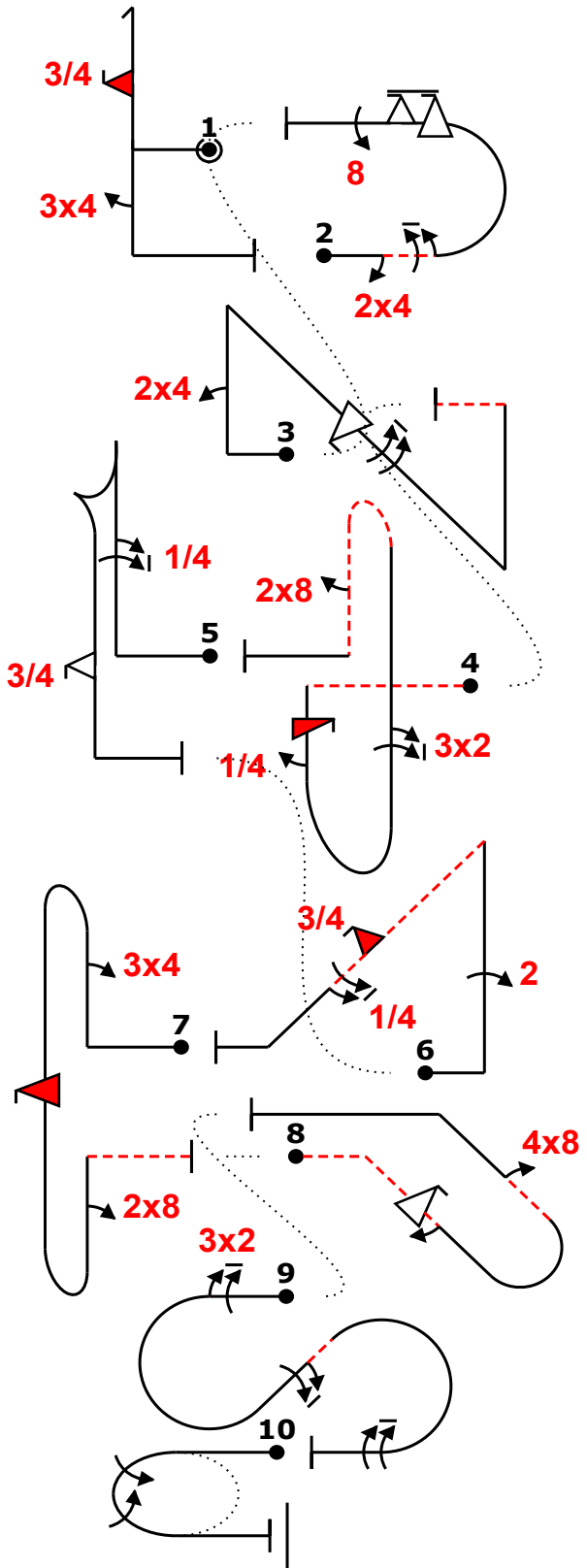
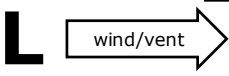

Fig	Grade	Pos	Remarks
1	.		
2	.		
3	.		
4	.		
5	.		
6	.		
7	.		
8	.		
9	.		
10	.		

Positioning
40 .

Too Low		Trg Violation	
Too High		Wing Rocks	
Interruptions		Disqual Fig	
Insertions		Other(note...)	

Fig 1 A	K	Fig 2 B	K	Fig 3	K	Fig 4 E	K	Fig 5	K	Fig 6 D	K	Fig 7	K	Fig 8 C	K	Fig 9	K	Fig 10	K
5.2.1.1	17	7.2.2.1	6	1.3.14.1	22	8.8.3.4	20	6.2.1.1	15	1.2.7.1	13	8.8.1.1	18	8.4.16.4	14	7.5.5.3	15	2.2.5.1	22
9.10.6.3	19	9.4.3.2	5	9.4.1.2	9	9.12.1.4	7	9.1.1.5	14	9.2.1.4	13	9.4.1.3	12	9.9.9.4	13	9.2.3.6	12		
9.4.5.3	8	9.1.3.6	10	9.9.4.4	11	9.1.5.1	2	9.9.5.3	11	9.10.4.3	13	9.10.10.4	15	9.1.4.2	4	9.1.2.6	12		
		9.9.3.6	14	9.1.4.8	12	9.2.1.6	17			9.1.4.5	9	9.8.1.1	7	9.8.2.2	9	9.1.3.8	12		
		9.8.3.4	15			9.8.5.1	3												
	44		50		54		49		40		48		52		40		51		22

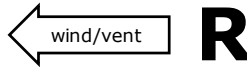

Figure K
450
Total K
490

Judges Name	
Signature	Number

Flight # 13

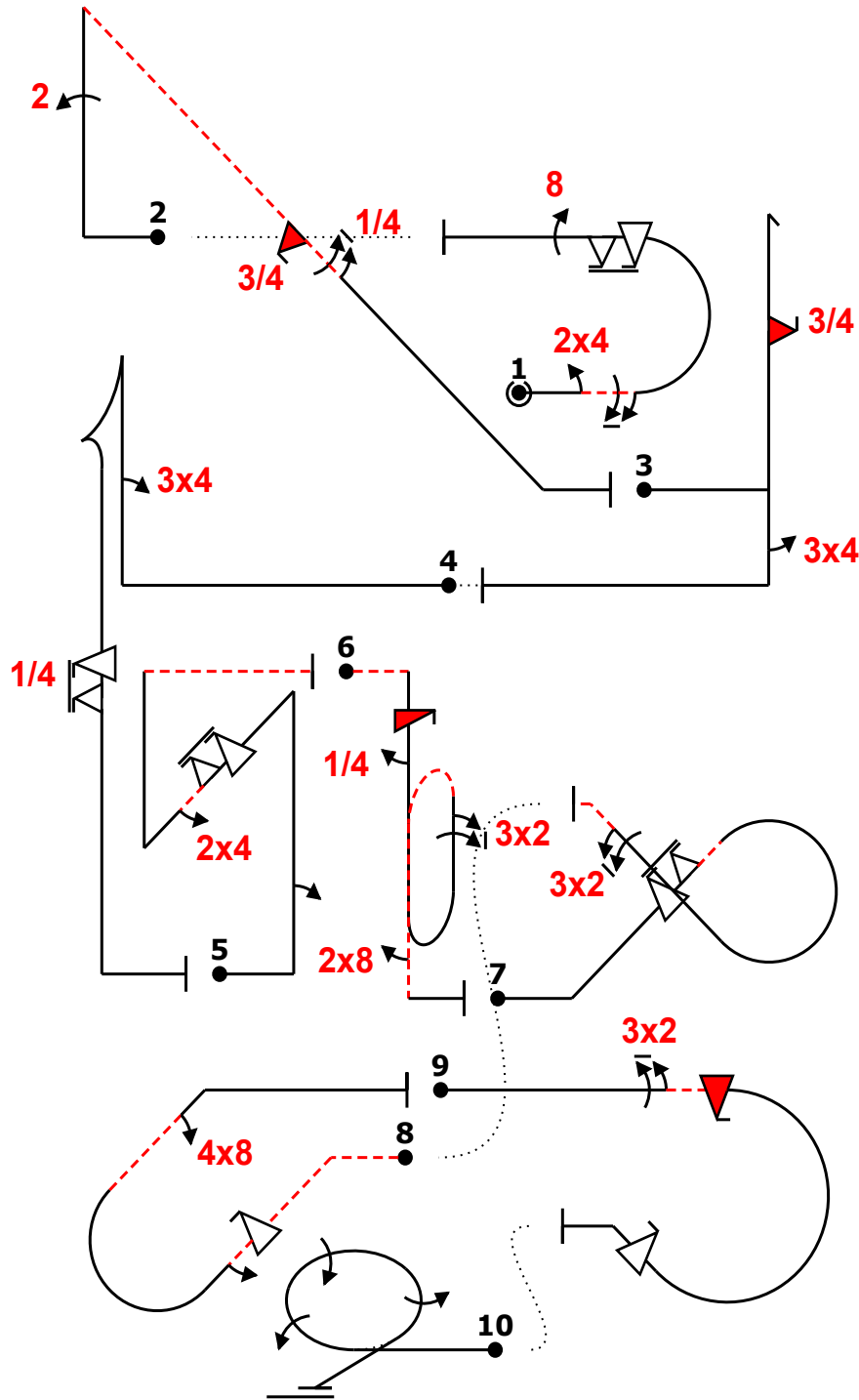

Fig	Grade	Pos	Remarks
1	.		
2	.		
3	.		
4	.		
5	.		
6	.		
7	.		
8	.		
9	.		
10	.		

Positioning 40	.
--------------------------	---

Too Low		Trg Violation	
Too High		Wing Rocks	
Interruptions		Disqual Fig	
Insertions		Other(note...)	

Fig 1 B	K	Fig 2 D	K	Fig 3 A	K	Fig 4	K	Fig 5	K	Fig 6 E	K	Fig 7	K	Fig 8 C	K	Fig 9	K	Fig 10	K
7.2.2.1	6	1.2.7.1	13	5.2.1.1	17	6.2.1.1	15	1.3.14.1	22	8.8.3.4	20	7.3.4.1	16	8.4.16.4	14	8.5.7.3	10	2.3.5.3	36
9.4.3.2	5	9.2.1.4	13	9.10.6.3	19	9.4.1.3	12	9.1.1.2	8	9.12.1.4	7	9.9.2.6	16	9.9.9.4	13	9.2.3.6	12		
9.1.3.6	10	9.10.4.3	13	9.4.5.3	8	9.9.5.5	13	9.9.4.6	14	9.1.5.1	2	9.2.2.6	14	9.1.4.2	4	9.10.3.4	13		
9.9.3.6	14	9.1.4.5	9					9.4.4.2	5	9.2.1.6	17			9.8.2.2	9	9.9.2.4	13		
9.8.3.4	15									9.8.5.1	3								
	50		48		44		40		49		49		46		40		48		36



Figure K
450
Total K
490

Judges Name	
Signature	Number

Flight # 13

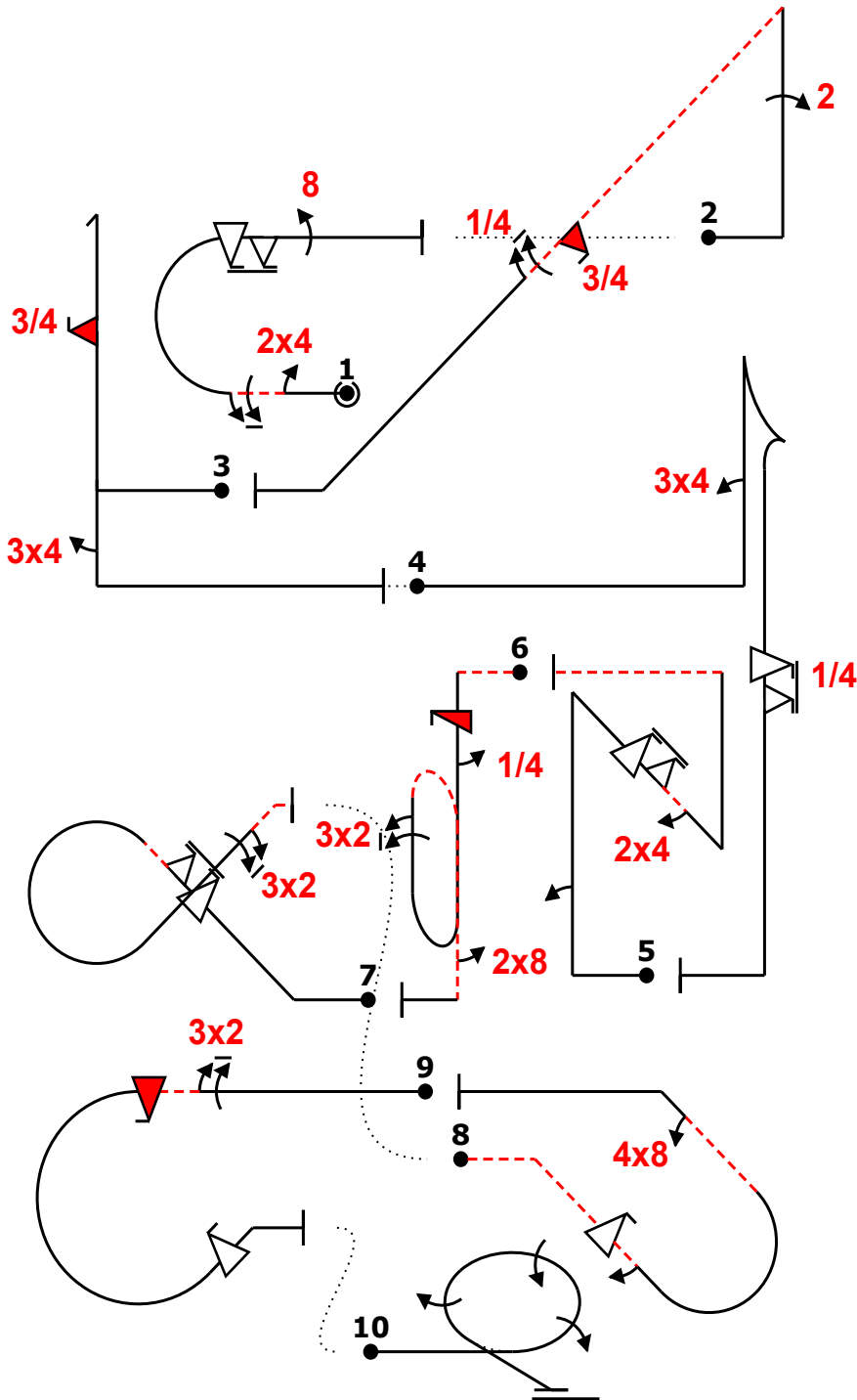
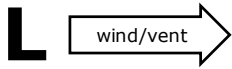

Fig	Grade	Pos	Remarks
1	.		
2	.		
3	.		
4	.		
5	.		
6	.		
7	.		
8	.		
9	.		
10	.		

Positioning 40	.
--------------------------	---

Too Low		Trg Violation	
Too High		Wing Rocks	
Interruptions		Disqual Fig	
Insertions		Other(note...)	

Fig 1 B	K	Fig 2 D	K	Fig 3 A	K	Fig 4	K	Fig 5	K	Fig 6 E	K	Fig 7	K	Fig 8 C	K	Fig 9	K	Fig 10	K
7.2.2.1	6	1.2.7.1	13	5.2.1.1	17	6.2.1.1	15	1.3.14.1	22	8.8.3.4	20	7.3.4.1	16	8.4.16.4	14	8.5.7.3	10	2.3.5.3	36
9.4.3.2	5	9.2.1.4	13	9.10.6.3	19	9.4.1.3	12	9.1.1.2	8	9.12.1.4	7	9.9.2.6	16	9.9.9.4	13	9.2.3.6	12		
9.1.3.6	10	9.10.4.3	13	9.4.5.3	8	9.9.5.5	13	9.9.4.6	14	9.1.5.1	2	9.2.2.6	14	9.1.4.2	4	9.10.3.4	13		
9.9.3.6	14	9.1.4.5	9					9.4.4.2	5	9.2.1.6	17			9.8.2.2	9	9.9.2.4	13		
9.8.3.4	15									9.8.5.1	3								
	50		48		44		40		49		49		46		40		48		36

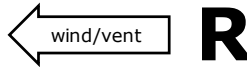

Figure K
450
Total K
490

Judges Name	
Signature	Number

Flight # 14

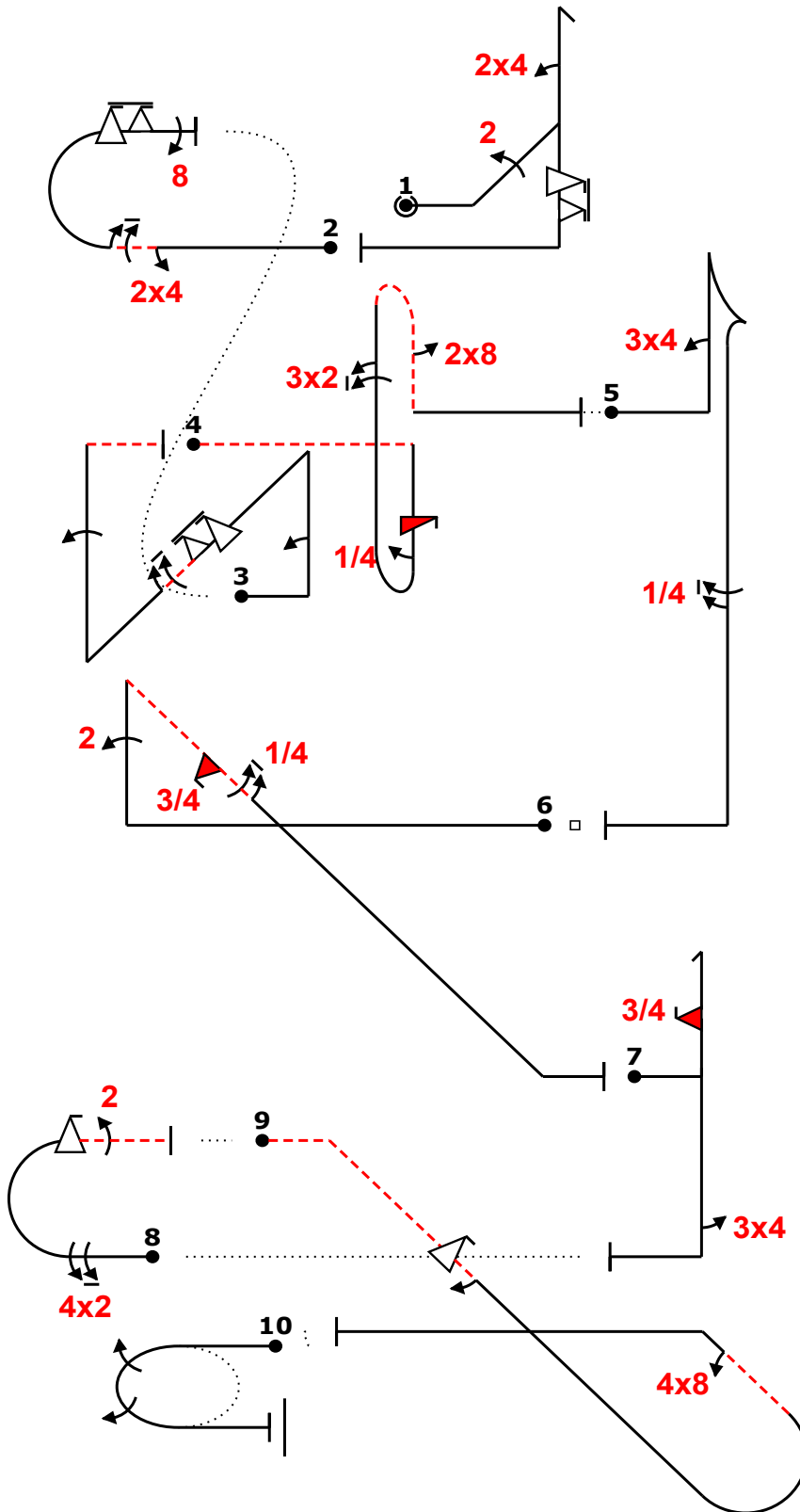

Fig	Grade	Pos	Remarks
1	.		
2	.		
3	.		
4	.		
5	.		
6	.		
7	.		
8	.		
9	.		
10	.		

Positioning 40	.
-------------------	---

Too Low		Trg Violation	
Too High		Wing Rocks	
Interruptions		Disqual Fig	
Insertions		Other(note...)	

Fig 1	K	Fig 2 B	K	Fig 3	K	Fig 4 E	K	Fig 5	K	Fig 6 D	K	Fig 7 A	K	Fig 8	K	Fig 9 C	K	Fig 10	K
5.3.1.1	18	7.2.2.1	6	1.3.14.1	22	8.8.3.4	20	6.2.1.1	15	1.2.7.1	13	5.2.1.1	6	7.2.1.1	6	8.4.16.4	14	2.2.5.3	24
9.2.2.4	11	9.4.3.2	5	9.1.1.2	8	9.12.1.4	7	9.4.1.3	12	9.2.1.4	13	9.10.6.3	19	9.2.3.8	15	9.9.9.4	13		
9.4.1.2	9	9.1.3.6	10	9.9.4.6	14	9.1.5.1	2	9.1.5.5	9	9.10.4.3	13	9.4.5.3	8	9.9.3.4	11	9.1.4.2	4		
9.9.5.6	14	9.9.3.6	14	9.1.4.6	10	9.2.1.6	17			9.1.4.5	9			9.2.3.4	9	9.8.2.2	9		
	52	9.8.3.4	15	9.1.1.4	12	9.8.5.1	3												24
			50		66		49		36		48		44		41		40		



Figure K
450
Total K
490

Judges Name	
Signature	Number

Flight # 14

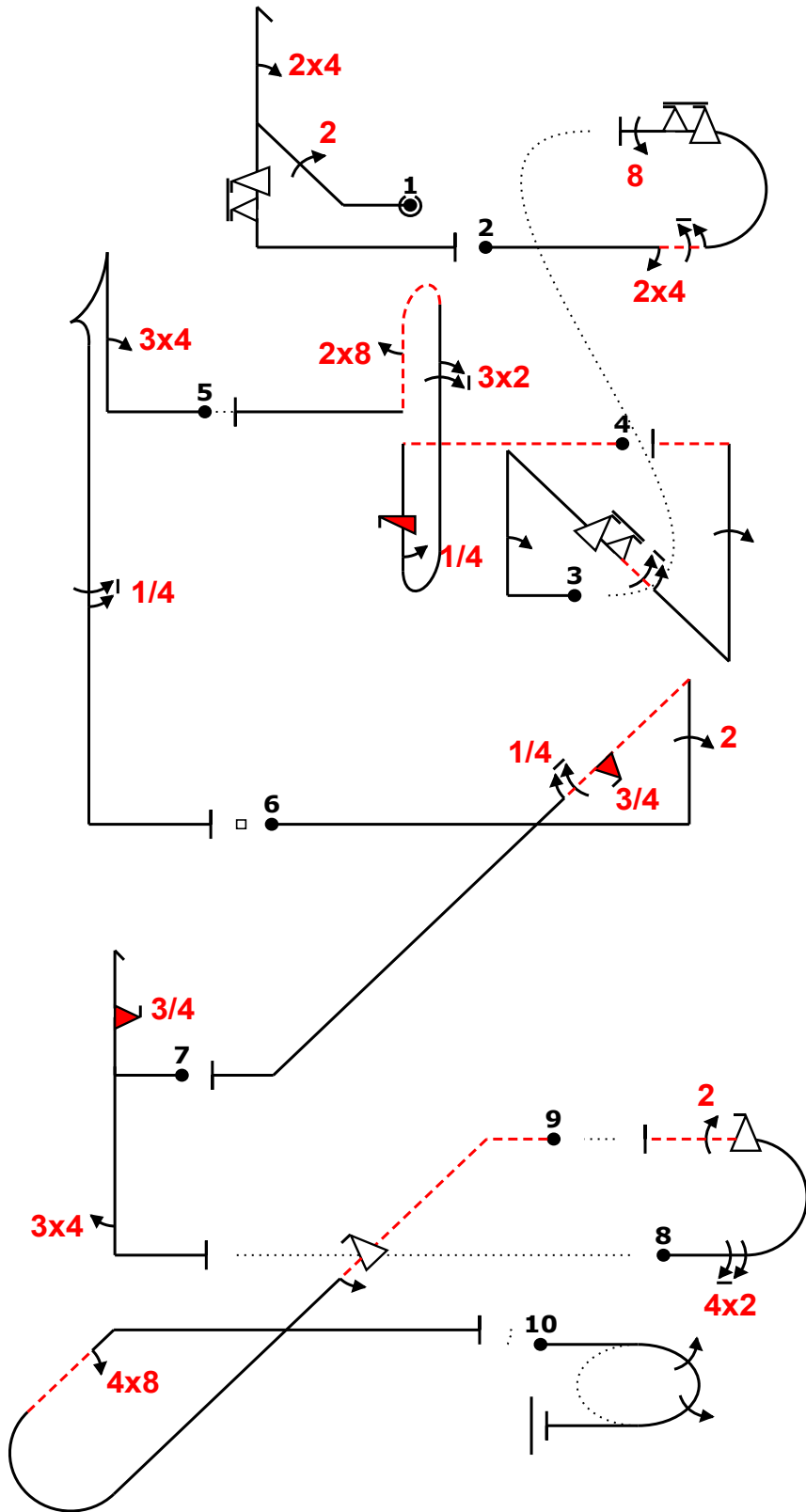
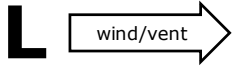

Fig	Grade	Pos	Remarks
1	.		
2	.		
3	.		
4	.		
5	.		
6	.		
7	.		
8	.		
9	.		
10	.		

Positioning 40	.
-------------------	---

Too Low		Trg Violation	
Too High		Wing Rocks	
Interruptions		Disqual Fig	
Insertions		Other(note...)	

Fig 1	K	Fig 2 B	K	Fig 3	K	Fig 4 E	K	Fig 5	K	Fig 6 D	K	Fig 7 A	K	Fig 8	K	Fig 9 C	K	Fig 10	K
5.3.1.1	18	7.2.2.1	6	1.3.14.1	22	8.8.3.4	20	6.2.1.1	15	1.2.7.1	13	5.2.1.1	17	7.2.1.1	6	8.4.16.4	14	2.2.5.3	24
9.2.2.4	11	9.4.3.2	5	9.1.1.2	8	9.12.1.4	7	9.4.1.3	12	9.2.1.4	13	9.10.6.3	19	9.2.3.8	15	9.9.9.4	13		
9.4.1.2	9	9.1.3.6	10	9.9.4.6	14	9.1.5.1	2	9.1.5.5	9	9.10.4.3	13	9.4.5.3	8	9.9.3.4	11	9.1.4.2	4		
9.9.5.6	14	9.9.3.6	14	9.1.4.6	10	9.2.1.6	17			9.1.4.5	9			9.2.3.4	9	9.8.2.2	9		
		9.8.3.4	15	9.1.1.4	12	9.8.5.1	3												
	52		50		66		49		36		48		44		41		40		24

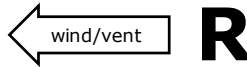

Figure K
450
Total K
490

Judges Name	
Signature	Number

Flight # 15

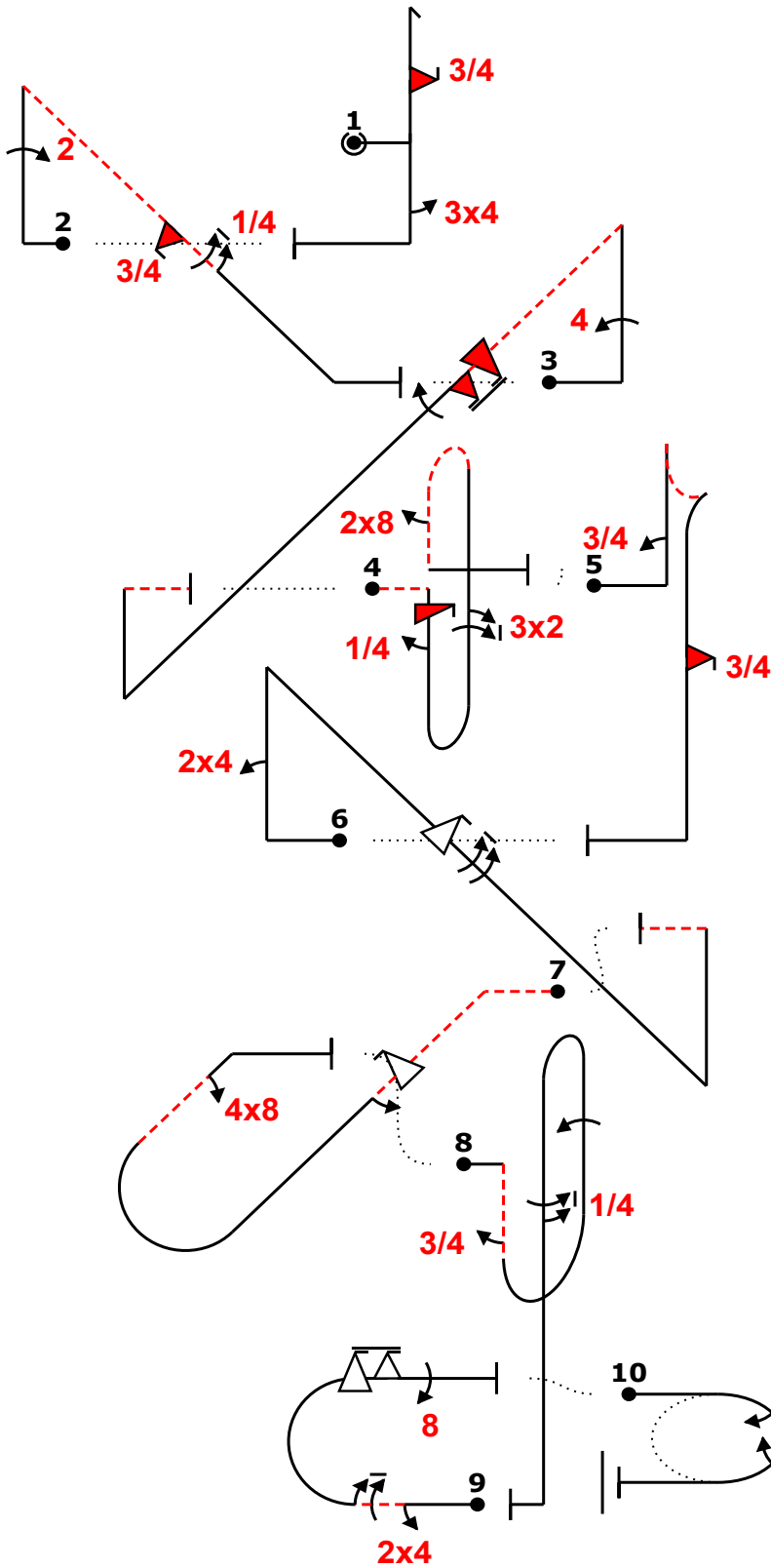

Fig	Grade	Pos	Remarks
1	.		
2	.		
3	.		
4	.		
5	.		
6	.		
7	.		
8	.		
9	.		
10	.		

Positioning 40	.
--------------------------	---

Too Low		Trg Violation	
Too High		Wing Rocks	
Interruptions		Disqual Fig	
Insertions		Other(note...)	

Fig 1 A	K	Fig 2 D	K	Fig 3	K	Fig 4 E	K	Fig 5	K	Fig 6	K	Fig 7 C	K	Fig 8	K	Fig 9 B	K	Fig 10	K
5.2.1.1	17	1.2.7.1	13	1.3.11.1	20	8.8.3.4	20	6.2.2.1	15	1.3.14.1	22	8.4.16.4	14	8.8.8.3	19	7.2.2.1	6	2.2.5.1	22
9.10.6.3	19	9.2.1.4	13	9.4.1.4	15	9.12.1.4	7	9.1.1.3	10	9.4.1.2	9	9.9.9.4	13	9.1.5.3	6	9.4.3.2	5		
9.4.5.3	8	9.10.4.3	13	9.10.4.6	16	9.1.5.1	2	9.10.5.3	13	9.9.4.4	11	9.1.4.2	4	9.1.1.4	12	9.1.3.6	10		
		9.1.4.5	9	9.1.4.4	8	9.2.1.6	17			9.1.4.8	12	9.8.2.2	9	9.1.5.5	9	9.9.3.6	14		
						9.8.5.1	3									9.8.3.4	15		
	44		48		59		49		38		54		40		46		50		22



CIVA Unlimited SEP 2023
Free Known EAC 23 PAVULLO, ITA

Figure K
450
Total K
490

Judges Name	
Signature	Number

Flight #
15

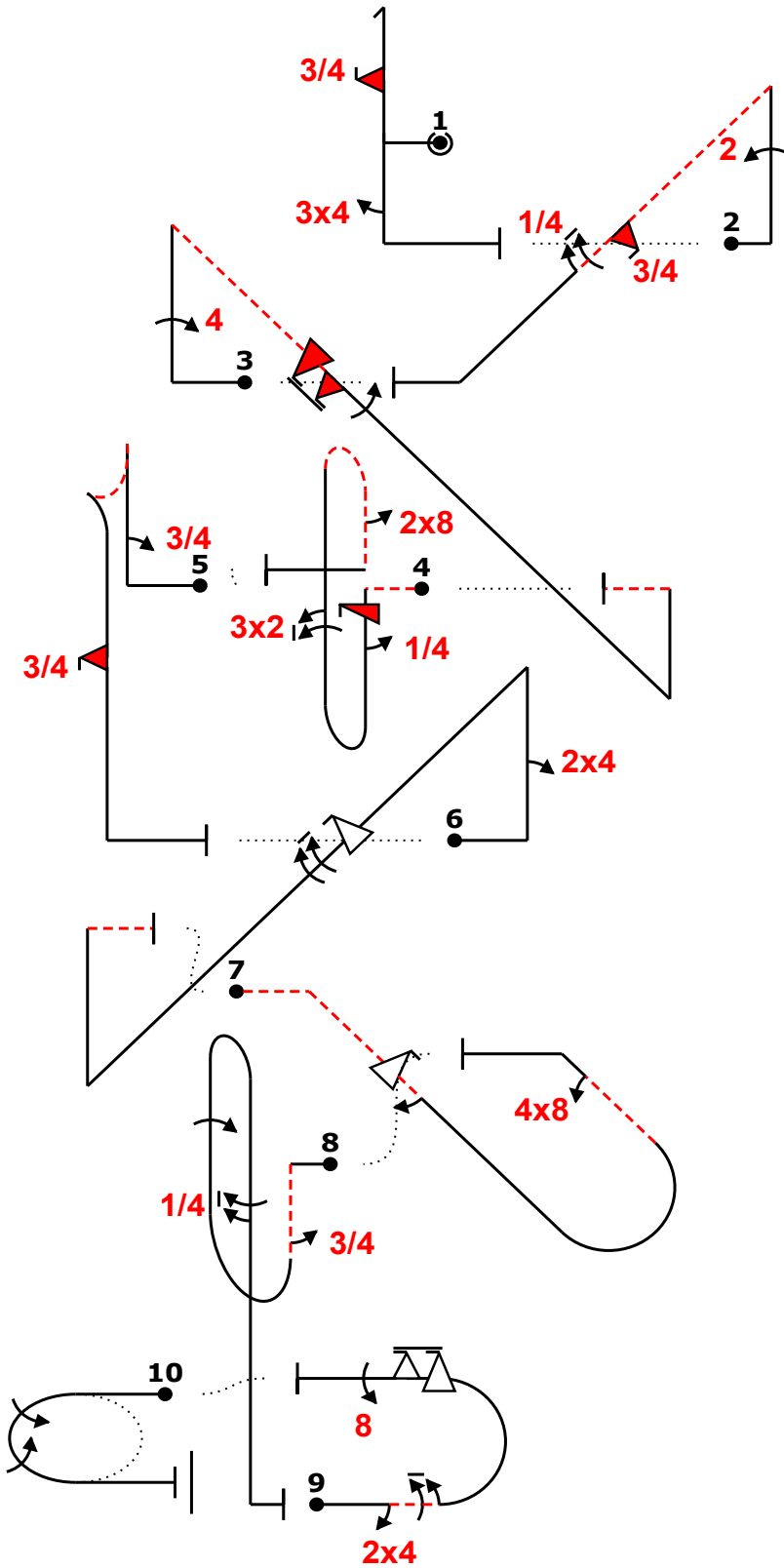
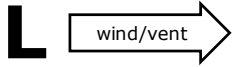

Fig	Grade	Pos	Remarks
1	.		
2	.		
3	.		
4	.		
5	.		
6	.		
7	.		
8	.		
9	.		
10	.		

Positioning
40

Too Low		Trg Violation	
Too High		Wing Rocks	
Interruptions		Disqual Fig	
Insertions		Other(note...)	

Fig 1 A	K	Fig 2 D	K	Fig 3	K	Fig 4 E	K	Fig 5	K	Fig 6	K	Fig 7 C	K	Fig 8	K	Fig 9 B	K	Fig 10	K
5.2.1.1	17	1.2.7.1	13	1.3.11.1	20	8.8.3.4	20	6.2.2.1	15	1.3.14.1	22	8.4.16.4	14	8.8.8.3	19	7.2.2.1	6	2.2.5.1	22
9.10.6.3	19	9.2.1.4	13	9.4.1.4	15	9.12.1.4	7	9.1.1.3	10	9.4.1.2	9	9.9.9.4	13	9.1.5.3	6	9.4.3.2	5		
9.4.5.3	8	9.10.4.3	13	9.10.4.6	16	9.1.5.1	2	9.10.5.3	13	9.9.4.4	11	9.1.4.2	4	9.1.1.4	12	9.1.3.6	10		
		9.1.4.5	9	9.1.4.4	8	9.2.1.6	17			9.1.4.8	12	9.8.2.2	9	9.1.5.5	9	9.9.3.6	14		
						9.8.5.1	3									9.8.3.4	15		
	44		48		59		49		38		54		40		46		50		22

Pilot: LOVICOURT LOIC

A/C: EXTRA 330 SC F-HXAL Team: FRA

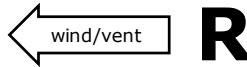

Figure K
450
Total K
490

Judges Name	
Signature	Number

Flight #
16

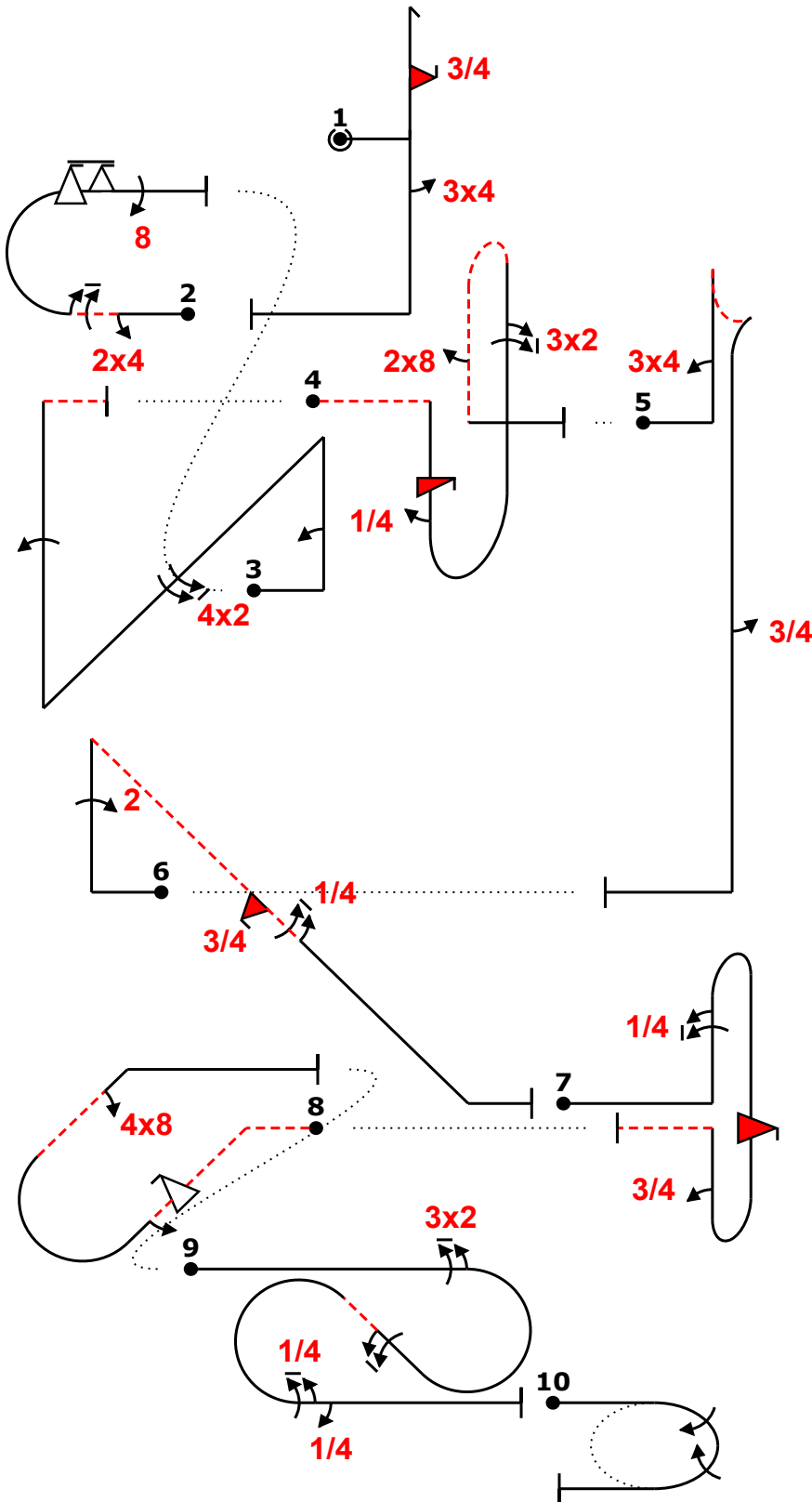

Fig	Grade	Pos	Remarks
1	.		
2	.		
3	.		
4	.		
5	.		
6	.		
7	.		
8	.		
9	.		
10	.		

Positioning
40

Too Low		Trg Violation	
Too High		Wing Rocks	
Interruptions		Disqual Fig	
Insertions		Other(note...)	

Fig 1 A	K	Fig 2 B	K	Fig 3	K	Fig 4 E	K	Fig 5	K	Fig 6 D	K	Fig 7	K	Fig 8 C	K	Fig 9	K	Fig 10	K
5.2.1.1	17	7.2.2.1	6	1.3.14.1	22	8.8.3.4	20	6.2.2.1	15	1.2.7.1	13	8.8.1.1	18	8.4.16.4	14	7.5.5.3	15	2.2.5.1	22
9.10.6.3	19	9.4.3.2	5	9.1.1.2	8	9.12.1.4	7	9.4.1.3	12	9.2.1.4	13	9.1.1.5	14	9.9.9.4	13	9.2.3.6	12		
9.4.5.3	8	9.1.3.6	10	9.2.4.8	15	9.1.5.1	2	9.1.5.3	6	9.10.4.3	13	9.10.10.4	15	9.1.4.2	4	9.1.2.6	12		
		9.9.3.6	14	9.1.1.4	12	9.2.1.6	17			9.1.4.5	9	9.1.1.3	10	9.8.2.2	9	9.1.3.5	9		
		9.8.3.4	15			9.8.5.1	3									9.1.3.1	2		
	44		50		57		49		33		48		57		40		50		22



Figure K
450
Total K
490

Judges Name	
Signature	Number

Flight # 16

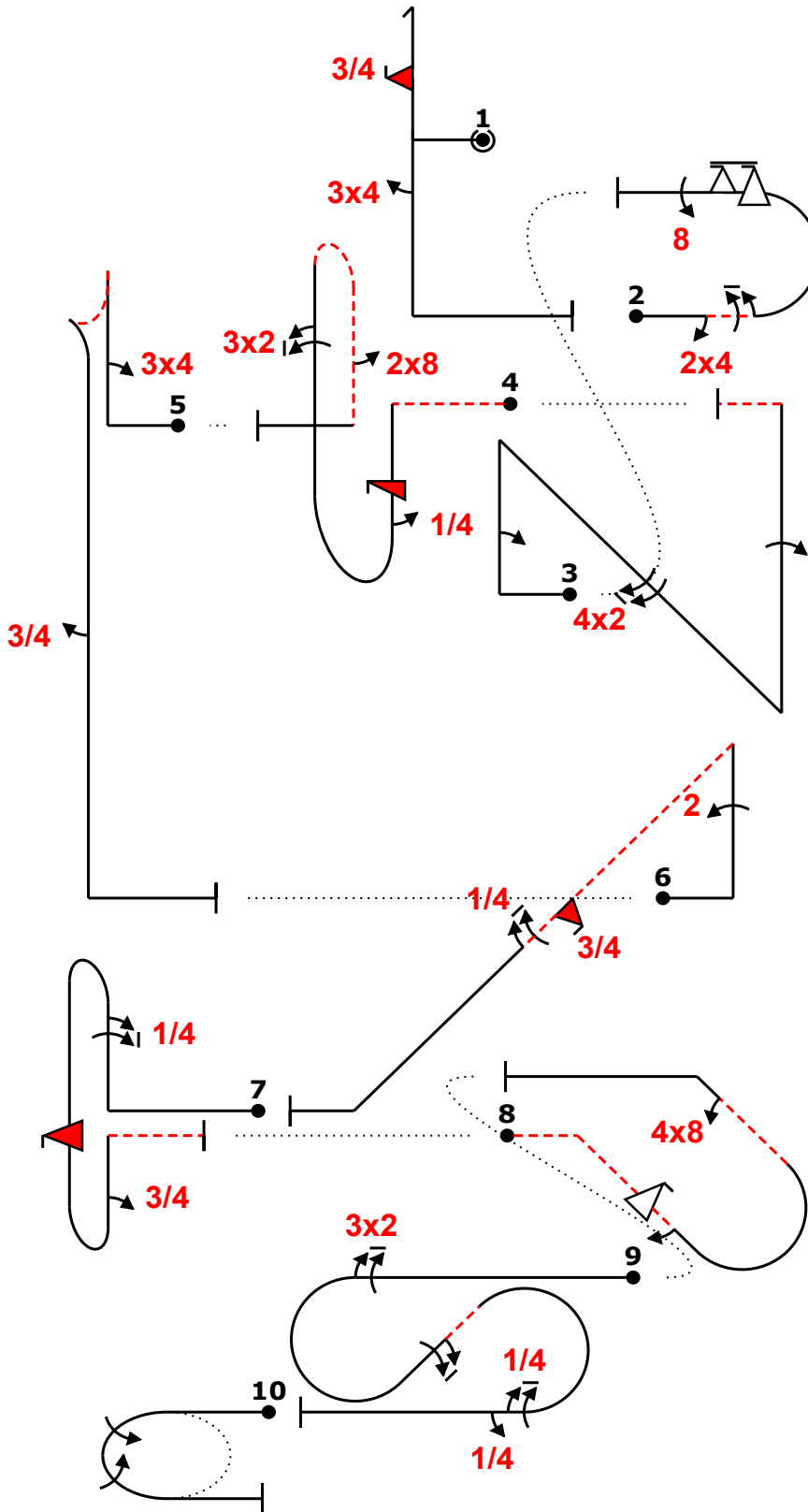
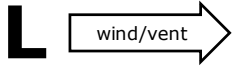

Fig	Grade	Pos	Remarks
1	.		
2	.		
3	.		
4	.		
5	.		
6	.		
7	.		
8	.		
9	.		
10	.		

Positioning 40	.
--------------------------	---

Too Low		Trg Violation	
Too High		Wing Rocks	
Interruptions		Disqual Fig	
Insertions		Other(note...)	

Fig 1 A	K	Fig 2 B	K	Fig 3	K	Fig 4 E	K	Fig 5	K	Fig 6 D	K	Fig 7	K	Fig 8 C	K	Fig 9	K	Fig 10	K
5.2.1.1	17	7.2.2.1	6	1.3.14.1	22	8.8.3.4	20	6.2.2.1	15	1.2.7.1	13	8.8.1.1	18	8.4.16.4	14	7.5.5.3	15	2.2.5.1	22
9.10.6.3	19	9.4.3.2	5	9.1.1.2	8	9.12.1.4	7	9.4.1.3	12	9.2.1.4	13	9.1.1.5	14	9.9.9.4	13	9.2.3.6	12		
9.4.5.3	8	9.1.3.6	10	9.2.4.8	15	9.1.5.1	2	9.1.5.3	6	9.10.4.3	13	9.10.10.4	15	9.1.4.2	4	9.1.2.6	12		
		9.9.3.6	14	9.1.1.4	12	9.2.1.6	17			9.1.4.5	9	9.1.1.3	10	9.8.2.2	9	9.1.3.5	9		
		9.8.3.4	15			9.8.5.1	3									9.1.3.1	2		
	44		50		57		49		33		48		57		40		50		22

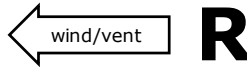

Figure K
450
Total K
490

Judges Name	
Signature	Number

Flight # 17

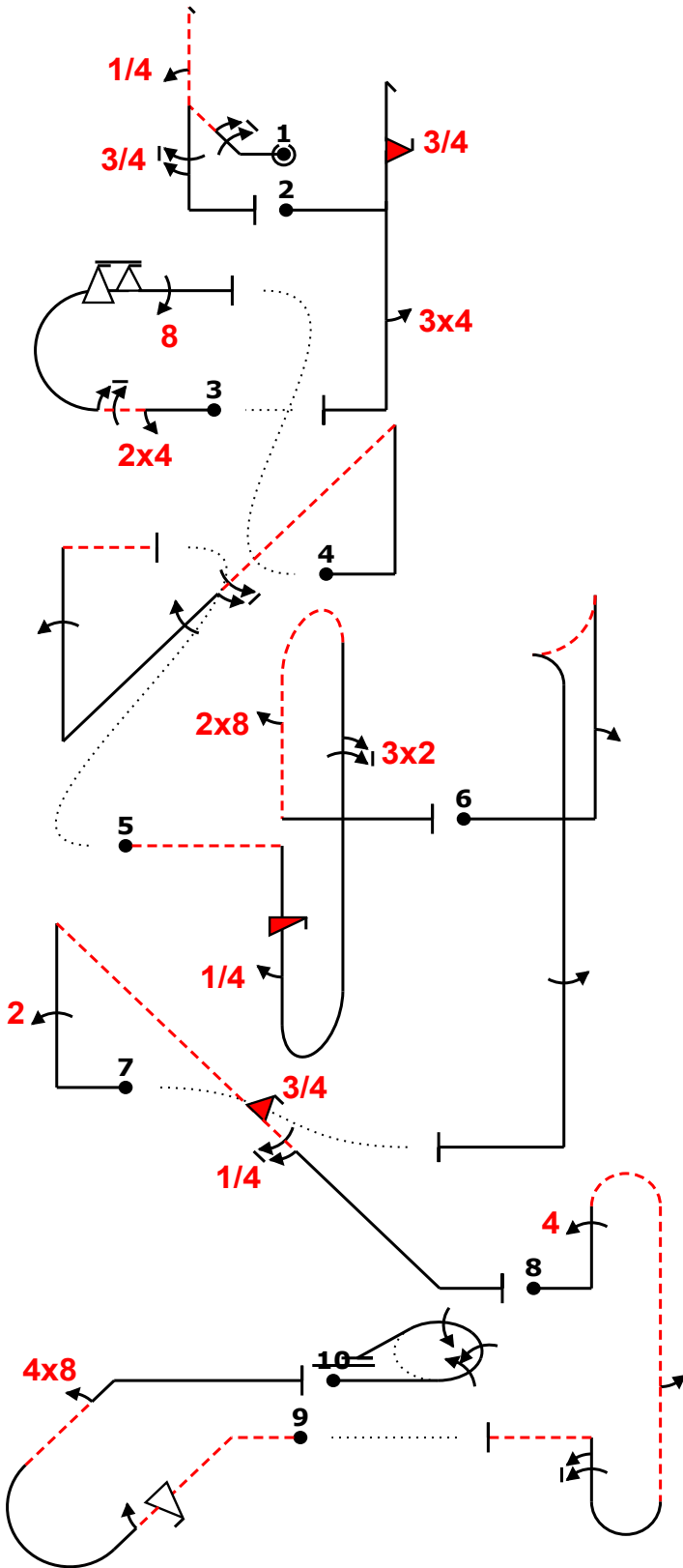

Fig	Grade	Pos	Remarks
1	.		
2	.		
3	.		
4	.		
5	.		
6	.		
7	.		
8	.		
9	.		
10	.		

Positioning 40	.
--------------------------	---

Too Low		Trg Violation	
Too High		Wing Rocks	
Interruptions		Disqual Fig	
Insertions		Other(note...)	

Fig 1	K	Fig 2 A	K	Fig 3 B	K	Fig 4	K	Fig 5 E	K	Fig 6	K	Fig 7 D	K	Fig 8	K	Fig 9 C	K	Fig 10	K
5.3.2.1	24	5.2.1.1	17	7.2.2.1	6	1.3.11.1	20	8.8.3.4	20	6.2.2.1	15	1.2.7.1	13	8.8.5.1	21	8.4.16.4	14	2.3.4.1	30
9.1.2.6	12	9.10.6.3	19	9.4.3.2	5	9.1.4.6	10	9.12.1.4	7	9.1.1.2	8	9.2.1.4	13	9.4.1.4	15	9.9.9.4	13		
9.1.1.1	6	9.4.5.3	8	9.1.3.6	10	9.1.4.4	8	9.1.5.1	2	9.1.5.4	8	9.10.4.3	13	9.1.5.2	4	9.1.4.2	4		
9.1.5.7	11			9.9.3.6	14	9.1.1.4	12	9.2.1.6	17			9.1.4.5	9	9.1.1.6	15	9.8.2.2	9		
				9.8.3.4	15			9.8.5.1	3										
	53		44		50		50		49		31		48		55		40		30



CIVA Unlimited SEP 2023
Free Known EAC 23 PAVULLO, ITA

Figure K
450
Total K
490

Judges Name	
Signature	Number

Flight #
17

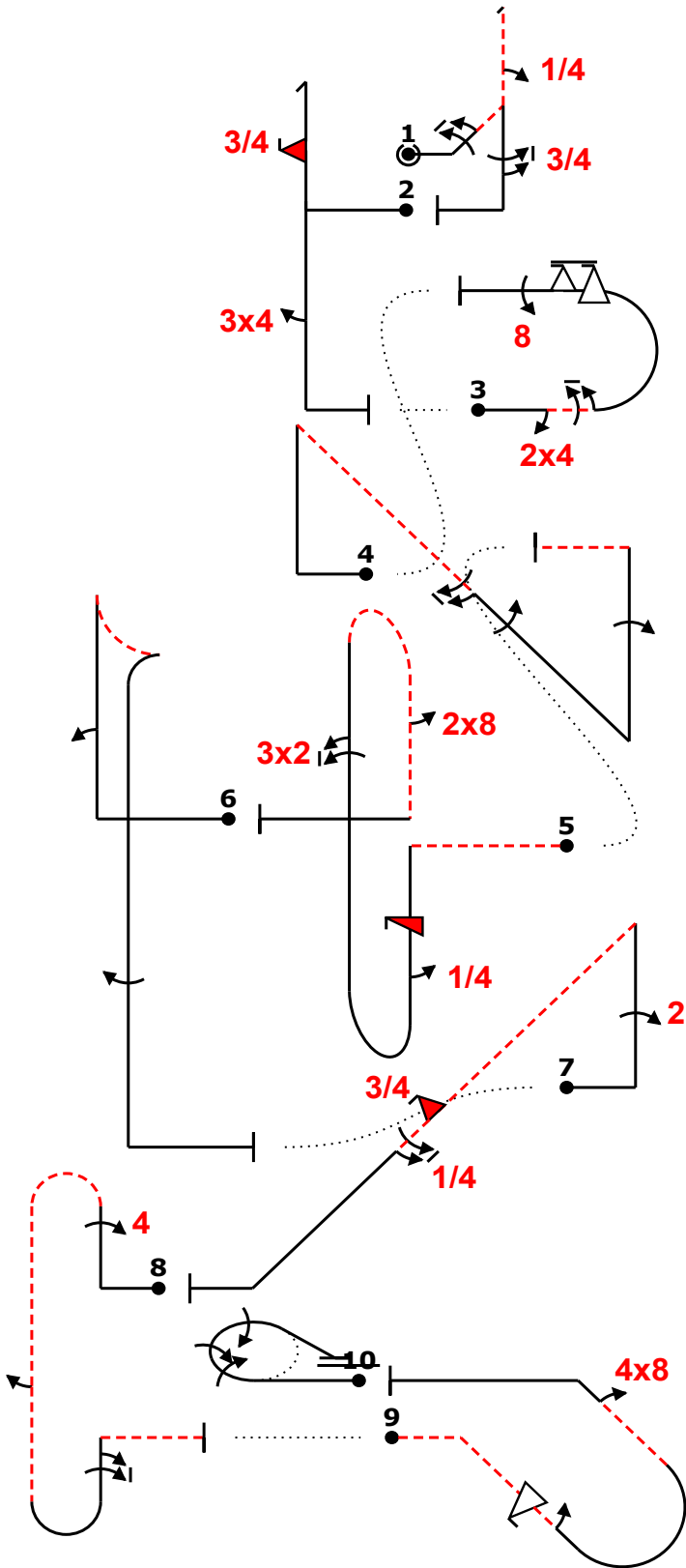
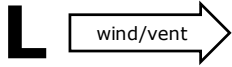

Fig	Grade	Pos	Remarks
1	.		
2	.		
3	.		
4	.		
5	.		
6	.		
7	.		
8	.		
9	.		
10	.		

Positioning
40

Too Low		Trg Violation	
Too High		Wing Rocks	
Interruptions		Disqual Fig	
Insertions		Other(note...)	

Fig 1	K	Fig 2 A	K	Fig 3 B	K	Fig 4	K	Fig 5 E	K	Fig 6	K	Fig 7 D	K	Fig 8	K	Fig 9 C	K	Fig 10	K
5.3.2.1	24	5.2.1.1	17	7.2.2.1	6	1.3.11.1	20	8.8.3.4	20	6.2.2.1	15	1.2.7.1	13	8.8.5.1	21	8.4.16.4	14	2.3.4.1	30
9.1.2.6	12	9.10.6.3	19	9.4.3.2	5	9.1.4.6	10	9.12.1.4	7	9.1.1.2	8	9.2.1.4	13	9.4.1.4	15	9.9.9.4	13		
9.1.1.1	6	9.4.5.3	8	9.1.3.6	10	9.1.4.4	8	9.1.5.1	2	9.1.5.4	8	9.10.4.3	13	9.1.5.2	4	9.1.4.2	4		
9.1.5.7	11			9.9.3.6	14	9.1.1.4	12	9.2.1.6	17			9.1.4.5	9	9.1.1.6	15	9.8.2.2	9		
				9.8.3.4	15			9.8.5.1	3										
	53		44		50		50		49		31		48		55		40		30

Pilot: GAMBARDILLA LEONE

A/C: CAP 232 D-ETOJ

Team: GRE



Figure K
450
Total K
490

Judges Name	
Signature	Number

Flight # 18

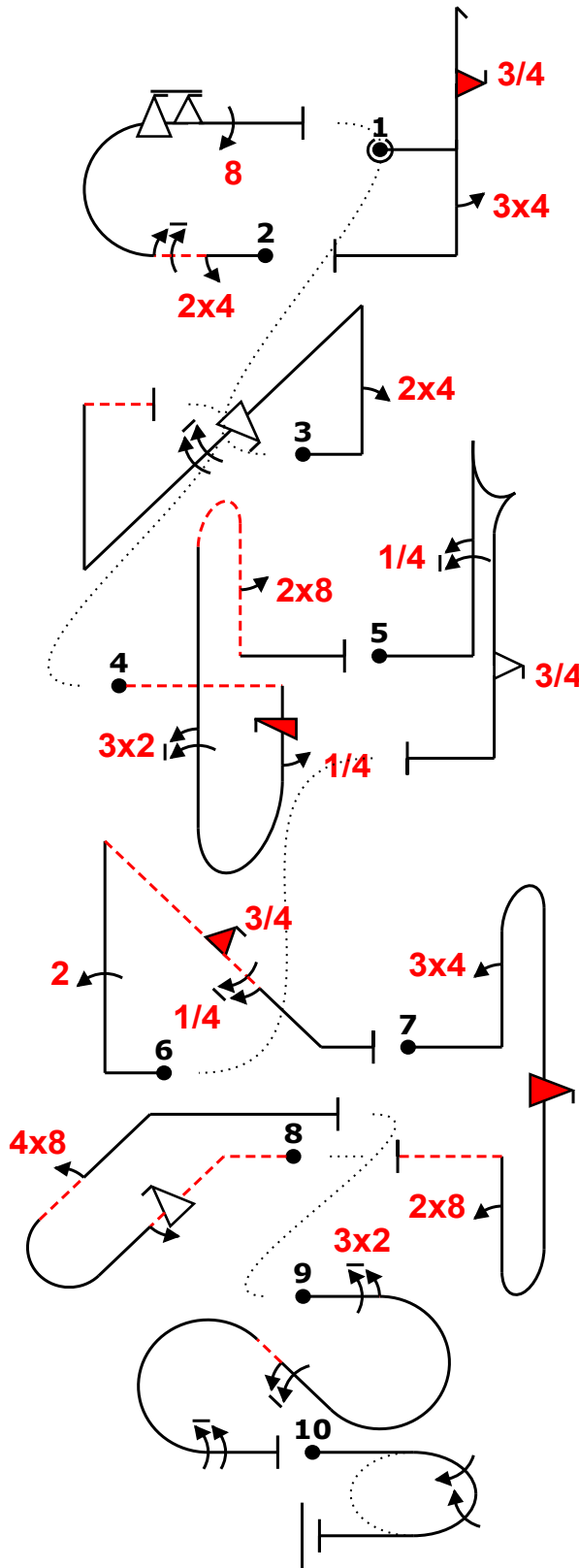
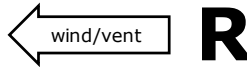

Fig	Grade	Pos	Remarks
1	.		
2	.		
3	.		
4	.		
5	.		
6	.		
7	.		
8	.		
9	.		
10	.		

Positioning 40	.
--------------------------	---

Too Low		Trg Violation	
Too High		Wing Rocks	
Interruptions		Disqual Fig	
Insertions		Other(note...)	

Fig 1 A	K	Fig 2 B	K	Fig 3	K	Fig 4 E	K	Fig 5	K	Fig 6 D	K	Fig 7	K	Fig 8 C	K	Fig 9	K	Fig 10	K
5.2.1.1	17	7.2.2.1	6	1.3.14.1	22	8.8.3.4	20	6.2.1.1	15	1.2.7.1	13	8.8.1.1	18	8.4.16.4	14	7.5.5.3	15	2.2.5.1	22
9.10.6.3	19	9.4.3.2	5	9.4.1.2	9	9.12.1.4	7	9.1.1.5	14	9.2.1.4	13	9.4.1.3	12	9.9.9.4	13	9.2.3.6	12		
9.4.5.3	8	9.1.3.6	10	9.9.4.4	11	9.1.5.1	2	9.9.5.3	11	9.10.4.3	13	9.10.10.4	15	9.1.4.2	4	9.1.2.6	12		
		9.9.3.6	14	9.1.4.8	12	9.2.1.6	17			9.1.4.5	9	9.8.1.1	7	9.8.2.2	9	9.1.3.8	12		
		9.8.3.4	15			9.8.5.1	3												
	44		50		54		49		40		48		52		40		51		22



Figure K
450
Total K
490

Judges Name		Flight # 18
Signature	Number	

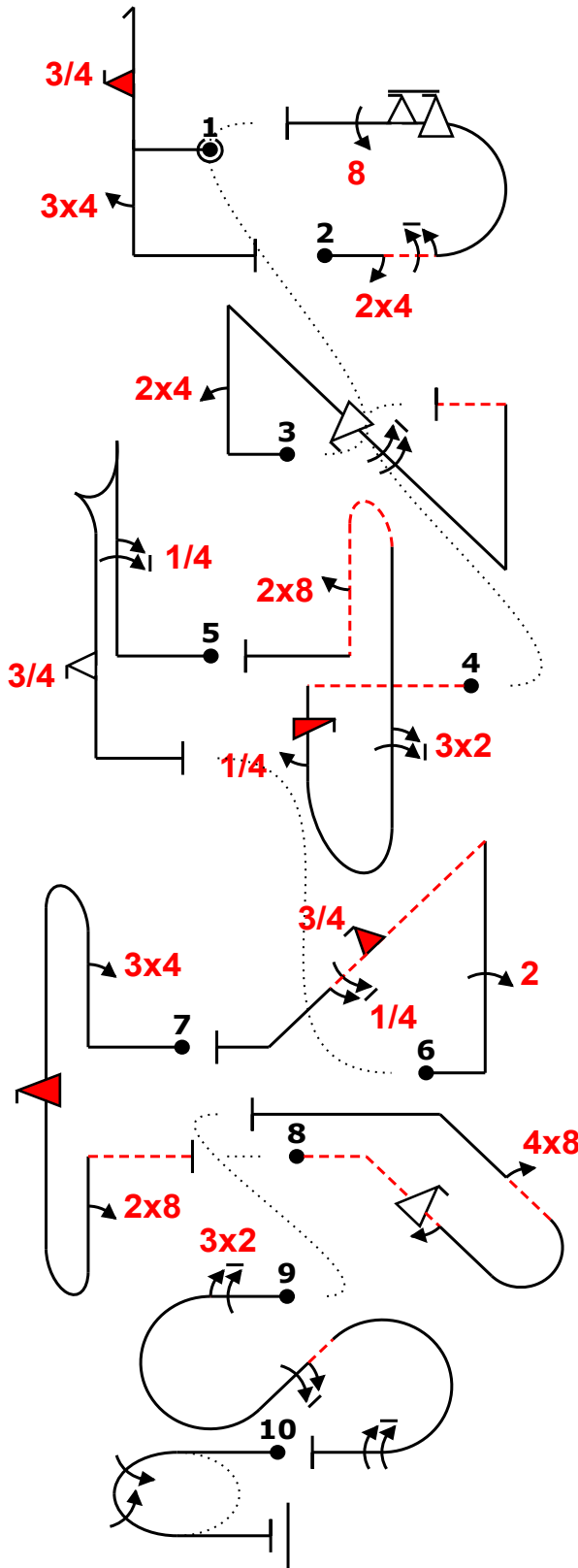
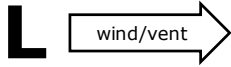

Fig	Grade	Pos	Remarks
1	.		
2	.		
3	.		
4	.		
5	.		
6	.		
7	.		
8	.		
9	.		
10	.		

Positioning	40	.
-------------	----	---

Too Low		Trg Violation	
Too High		Wing Rocks	
Interruptions		Disqual Fig	
Insertions		Other(note...)	

Fig 1 A	K	Fig 2 B	K	Fig 3	K	Fig 4 E	K	Fig 5	K	Fig 6 D	K	Fig 7	K	Fig 8 C	K	Fig 9	K	Fig 10	K
5.2.1.1	17	7.2.2.1	6	1.3.14.1	22	8.8.3.4	20	6.2.1.1	15	1.2.7.1	13	8.8.1.1	18	8.4.16.4	14	7.5.5.3	15	2.2.5.1	22
9.10.6.3	19	9.4.3.2	5	9.4.1.2	9	9.12.1.4	7	9.1.1.5	14	9.2.1.4	13	9.4.1.3	12	9.9.9.4	13	9.2.3.6	12		
9.4.5.3	8	9.1.3.6	10	9.9.4.4	11	9.1.5.1	2	9.9.5.3	11	9.10.4.3	13	9.10.10.4	15	9.1.4.2	4	9.1.2.6	12		
		9.9.3.6	14	9.1.4.8	12	9.2.1.6	17			9.1.4.5	9	9.8.1.1	7	9.8.2.2	9	9.1.3.8	12		
		9.8.3.4	15			9.8.5.1	3												
	44		50		54		49		40		48		52		40		51		22



Figure K
450
Total K
490

Judges Name	
Signature	Number

Flight # 19

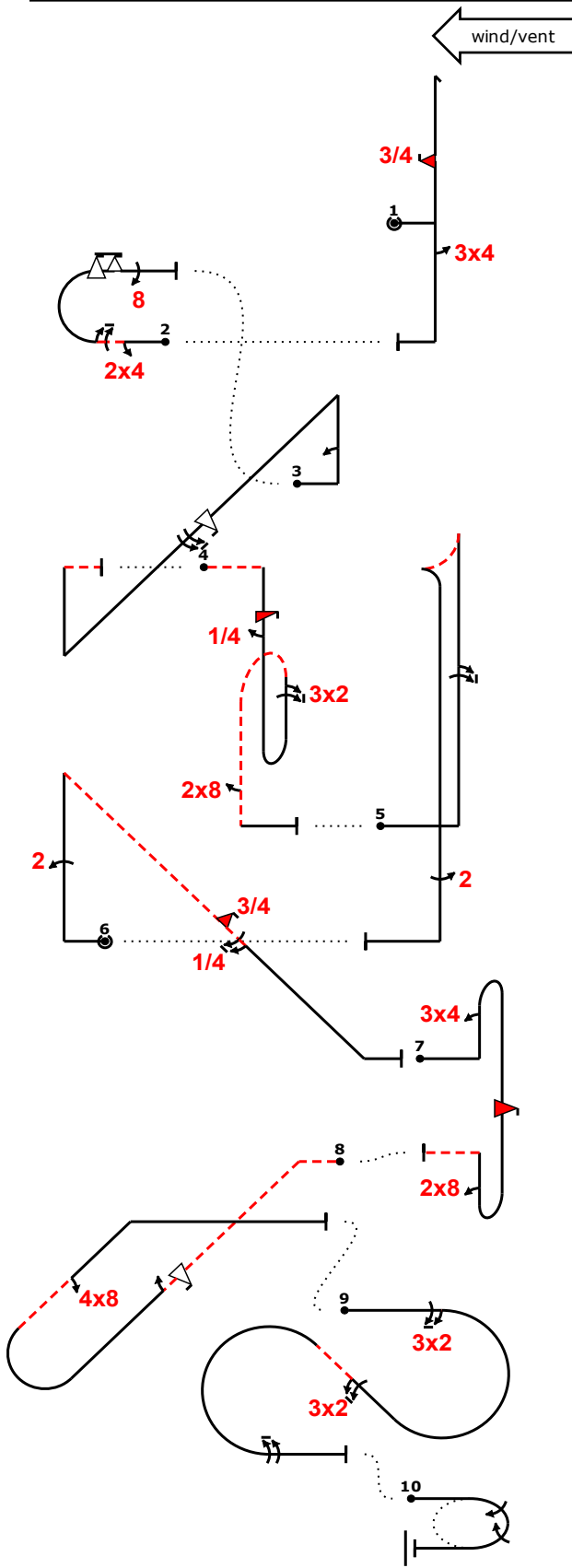

Fig	Grade	Pos	Remarks
1	.		
2	.		
3	.		
4	.		
5	.		
6	.		
7	.		
8	.		
9	.		
10	.		

Positioning 40	.
--------------------------	---

Too Low		Trg Violation	
Too High		Wing Rocks	
Interruptions		Disqual Fig	
Insertions		Other(note...)	

Fig 1 A	K	Fig 2 B	K	Fig 3	K	Fig 4 E	K	Fig 5	K	Fig 6 D	K	Fig 7	K	Fig 8 C	K	Fig 9	K	Fig 10	K
5.2.1.1	17	7.2.2.1	6	1.3.14.1	22	8.8.3.4	20	6.2.2.1	15	1.2.7.1	13	8.8.1.1	18	8.4.16.4	14	7.5.5.3	15	2.2.5.1	22
9.10.6.3	19	9.4.3.2	5	9.1.1.2	8	9.12.1.4	7	9.1.1.6	15	9.2.1.4	13	9.4.1.3	12	9.9.9.4	13	9.2.3.6	12		
9.4.5.3	8	9.1.3.6	10	9.9.4.4	11	9.1.5.1	2	9.2.5.4	9	9.10.4.3	13	9.10.10.4	15	9.1.4.2	4	9.2.2.6	14		
		9.9.3.6	14	9.1.4.8	12	9.2.1.6	17			9.1.4.5	9	9.8.1.1	7	9.8.2.2	9	9.1.3.8	12		
		9.8.3.4	15			9.8.5.1	3												
	44		50		53		49		39		48		52		40		53		22



Figure K
450
Total K
490

Judges Name	
Signature	Number

Flight #
19

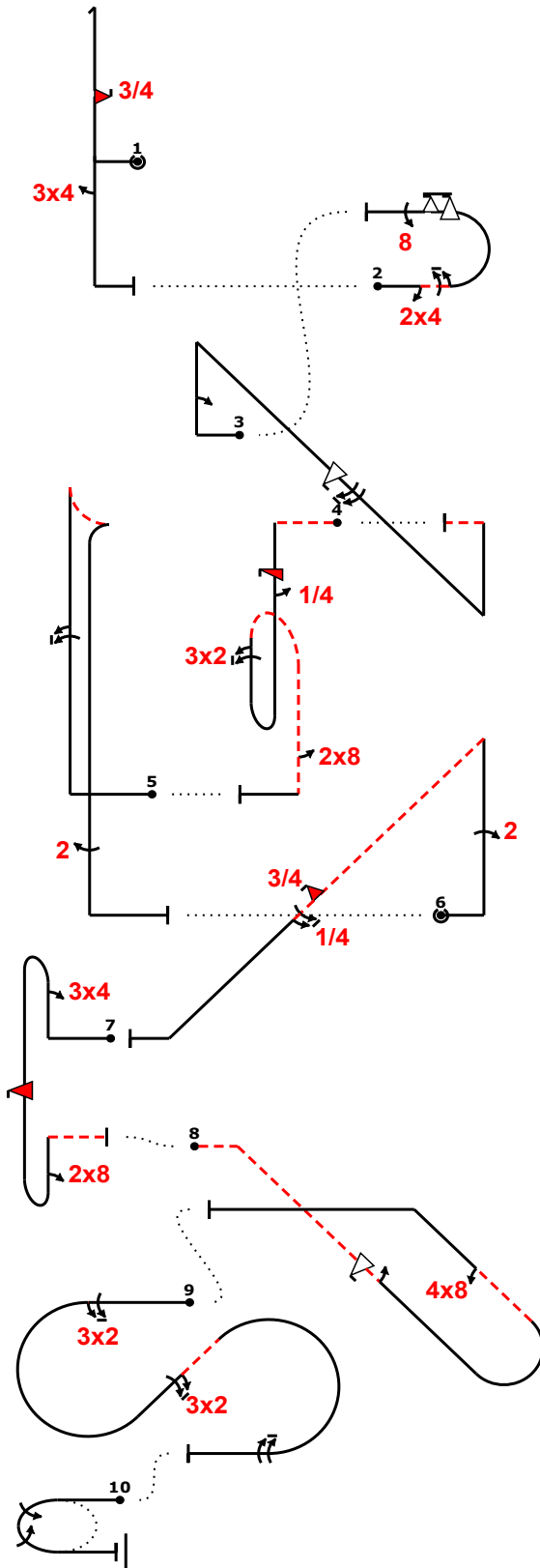
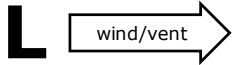

Fig	Grade	Pos	Remarks
1	.		
2	.		
3	.		
4	.		
5	.		
6	.		
7	.		
8	.		
9	.		
10	.		

Positioning
40

Too Low		Trg Violation	
Too High		Wing Rocks	
Interruptions		Disqual Fig	
Insertions		Other(note...)	

Fig 1 A	K	Fig 2 B	K	Fig 3	K	Fig 4 E	K	Fig 5	K	Fig 6 D	K	Fig 7	K	Fig 8 C	K	Fig 9	K	Fig 10	K
5.2.1.1	17	7.2.2.1	6	1.3.14.1	22	8.8.3.4	20	6.2.2.1	15	1.2.7.1	13	8.8.1.1	18	8.4.16.4	14	7.5.5.3	15	2.2.5.1	22
9.10.6.3	19	9.4.3.2	5	9.1.1.2	8	9.12.1.4	7	9.1.1.6	15	9.2.1.4	13	9.4.1.3	12	9.9.9.4	13	9.2.3.6	12		
9.4.5.3	8	9.1.3.6	10	9.9.4.4	11	9.1.5.1	2	9.2.5.4	9	9.10.4.3	13	9.10.10.4	15	9.1.4.2	4	9.2.2.6	14		
		9.9.3.6	14	9.1.4.8	12	9.2.1.6	17			9.1.4.5	9	9.8.1.1	7	9.8.2.2	9	9.1.3.8	12		
		9.8.3.4	15			9.8.5.1	3												
	44		50		53		49		39		48		52		40		53		22

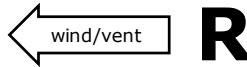

Figure K
450
Total K
490

Judges Name	
Signature	Number

Flight # 20

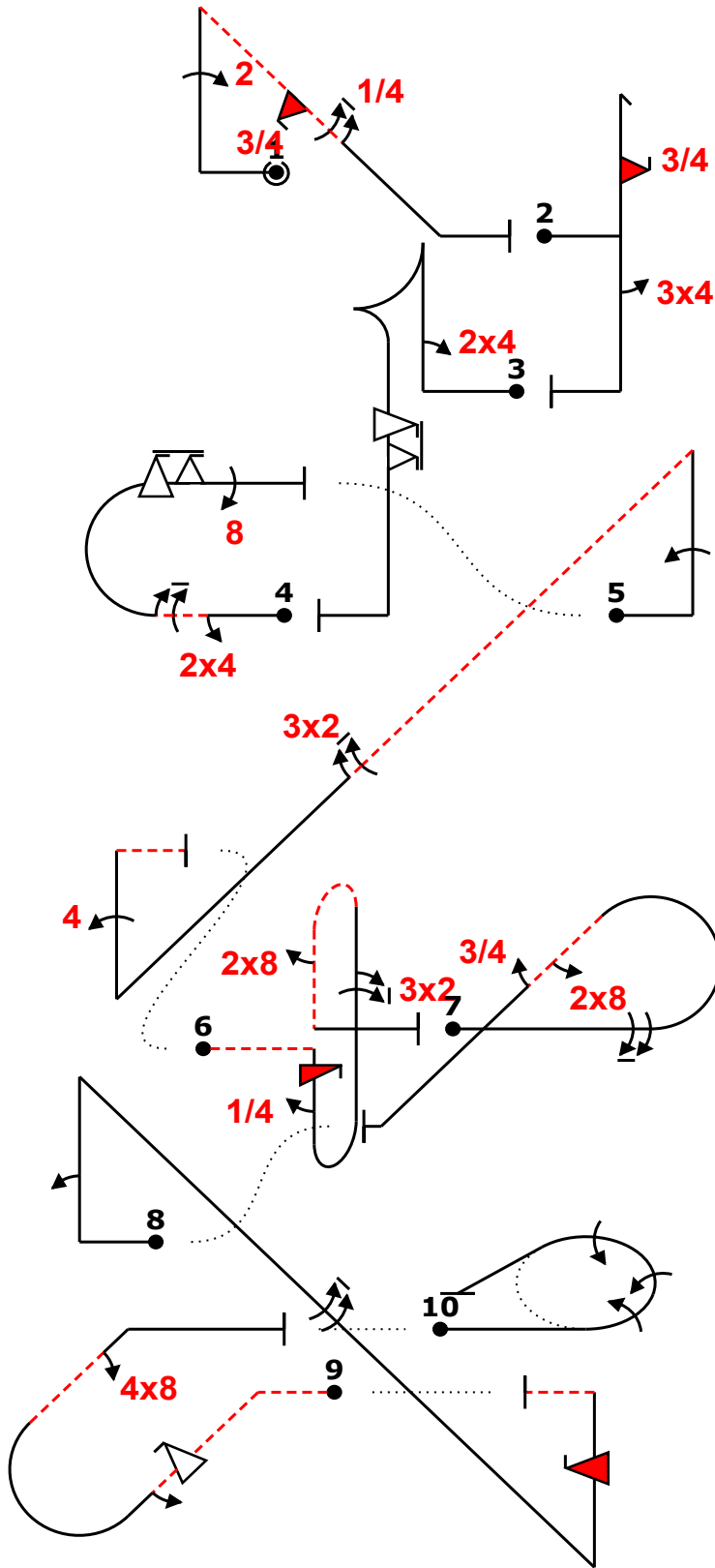

Fig	Grade	Pos	Remarks
1	.		
2	.		
3	.		
4	.		
5	.		
6	.		
7	.		
8	.		
9	.		
10	.		

Positioning 40	.
--------------------------	---

Too Low		Trg Violation	
Too High		Wing Rocks	
Interruptions		Disqual Fig	
Insertions		Other(note...)	

Fig 1 D	K	Fig 2 A	K	Fig 3	K	Fig 4 B	K	Fig 5	K	Fig 6 E	K	Fig 7	K	Fig 8	K	Fig 9 C	K	Fig 10	K
1.2.7.1	13	5.2.1.1	17	6.2.1.1	15	7.2.2.1	6	1.3.11.1	20	8.8.3.4	20	8.5.6.1	10	1.3.14.1	22	8.4.16.4	14	2.3.4.1	30
9.2.1.4	13	9.10.6.3	19	9.4.1.2	9	9.4.3.2	5	9.1.1.4	12	9.12.1.4	7	9.1.3.8	12	9.1.1.2	8	9.9.9.4	13		
9.10.4.3	13	9.4.5.3	8	9.9.5.6	14	9.1.3.6	10	9.2.4.6	12	9.1.5.1	2	9.8.4.1	3	9.1.4.8	12	9.1.4.2	4		
9.1.4.5	9					9.9.3.6	14	9.4.1.4	15	9.2.1.6	17	9.1.4.3	6	9.10.6.4	19	9.8.2.2	9		
						9.8.3.4	15			9.8.5.1	3								
	48		44		38		50		59		49		31		61		40		30



Figure K
450
Total K
490

Judges Name	
Signature	Number

Flight # 20

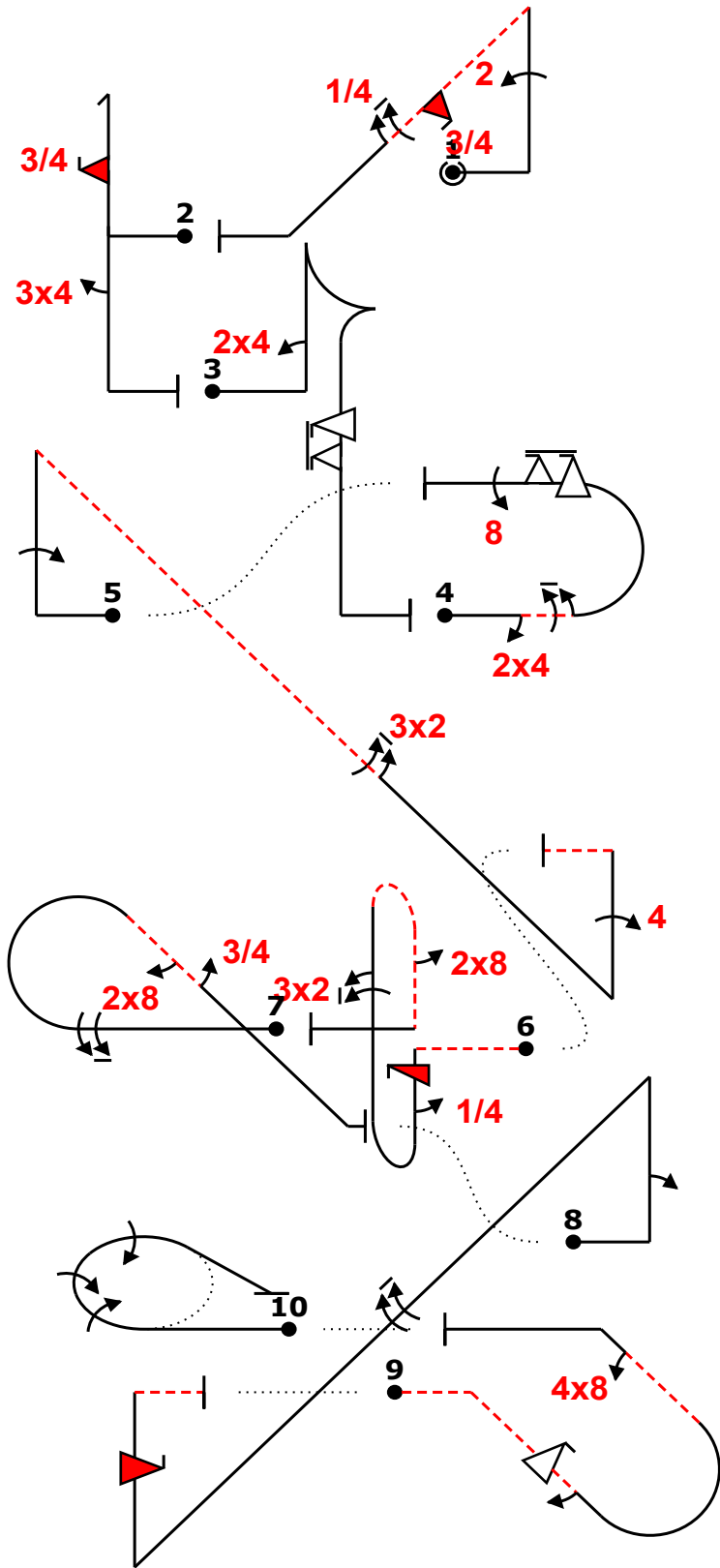
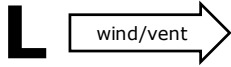

Fig	Grade	Pos	Remarks
1	.		
2	.		
3	.		
4	.		
5	.		
6	.		
7	.		
8	.		
9	.		
10	.		

Positioning 40	.
-------------------	---

Too Low		Trg Violation	
Too High		Wing Rocks	
Interruptions		Disqual Fig	
Insertions		Other(note...)	

Fig 1 D	K	Fig 2 A	K	Fig 3	K	Fig 4 B	K	Fig 5	K	Fig 6 E	K	Fig 7	K	Fig 8	K	Fig 9 C	K	Fig 10	K
1.2.7.1	13	5.2.1.1	17	6.2.1.1	15	7.2.2.1	6	1.3.11.1	20	8.8.3.4	20	8.5.6.1	10	1.3.14.1	22	8.4.16.4	14	2.3.4.1	30
9.2.1.4	13	9.10.6.3	19	9.4.1.2	9	9.4.3.2	5	9.1.1.4	12	9.12.1.4	7	9.1.3.8	12	9.1.1.2	8	9.9.9.4	13		
9.10.4.3	13	9.4.5.3	8	9.9.5.6	14	9.1.3.6	10	9.2.4.6	12	9.1.5.1	2	9.8.4.1	3	9.1.4.8	12	9.1.4.2	4		
9.1.4.5	9					9.9.3.6	14	9.4.1.4	15	9.2.1.6	17	9.1.4.3	6	9.10.6.4	19	9.8.2.2	9		
	48		44		38	9.8.3.4	15			9.8.5.1	3								30
							50		59		49		31		61		40		30

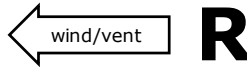

Figure K
450
Total K
490

Judges Name	
Signature	Number

Flight # 21

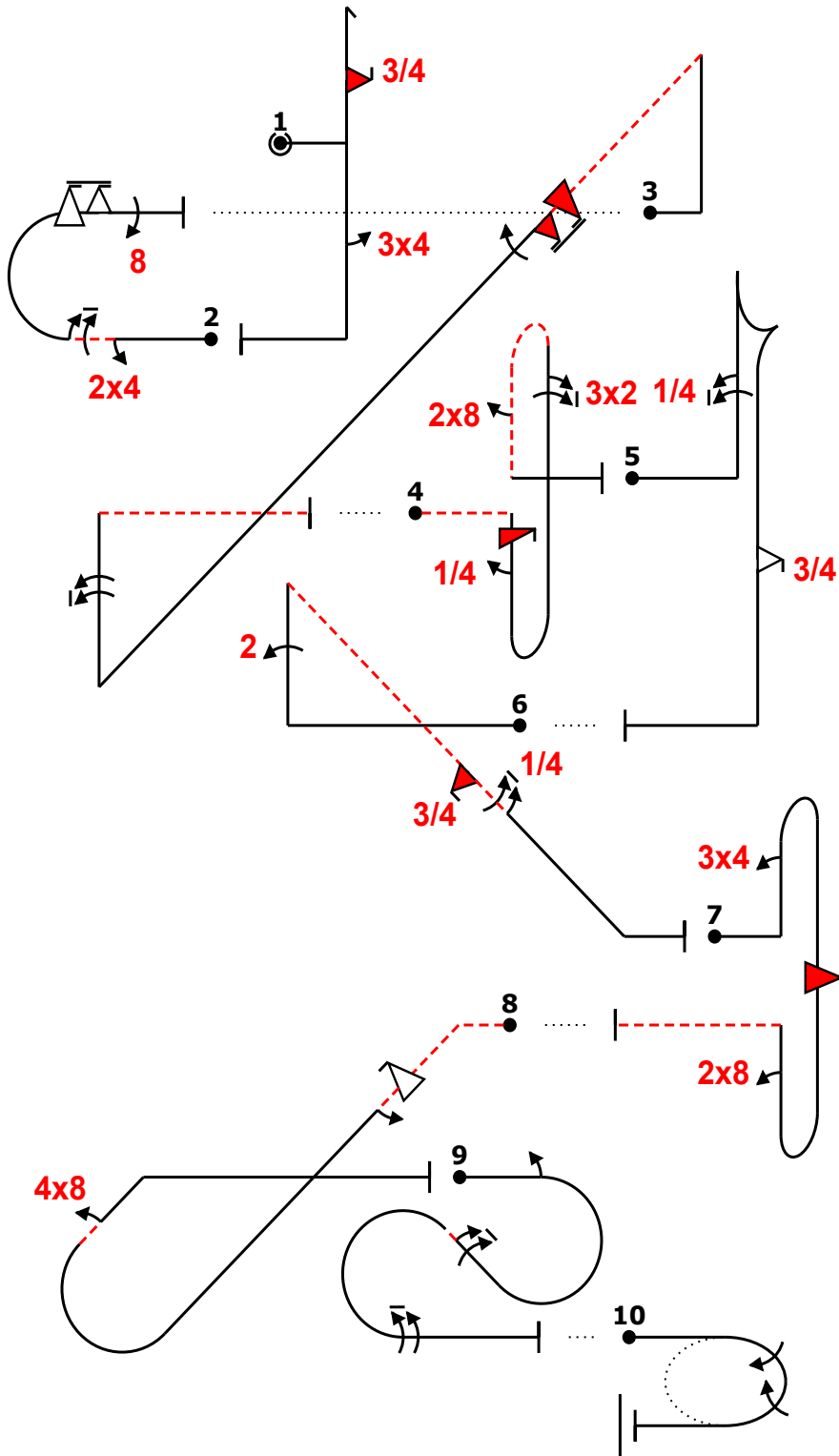

Fig	Grade	Pos	Remarks
1	.		
2	.		
3	.		
4	.		
5	.		
6	.		
7	.		
8	.		
9	.		
10	.		

Positioning 40	.
--------------------------	---

Too Low		Trg Violation	
Too High		Wing Rocks	
Interruptions		Disqual Fig	
Insertions		Other(note...)	

Fig 1 A	K	Fig 2 B	K	Fig 3	K	Fig 4 E	K	Fig 5	K	Fig 6 D	K	Fig 7	K	Fig 8 C	K	Fig 9	K	Fig 10	K
5.2.1.1	17	7.2.2.1	6	1.3.11.1	20	8.8.3.4	20	6.2.1.1	15	1.2.7.1	13	8.8.1.1	18	8.4.16.4	14	7.5.5.3	15	2.2.5.1	22
9.10.6.3	19	9.4.3.2	5	9.10.4.6	16	9.12.1.4	7	9.1.1.5	14	9.2.1.4	13	9.4.1.3	12	9.9.9.4	13	9.1.3.2	4		
9.4.5.3	8	9.1.3.6	10	9.1.4.4	8	9.1.5.1	2	9.9.5.3	11	9.10.4.3	13	9.10.10.4	15	9.1.4.2	4	9.1.2.6	12		
		9.9.3.6	14	9.1.1.8	18	9.2.1.6	17			9.1.4.5	9	9.8.1.1	7	9.8.2.2	9	9.1.3.8	12		
		9.8.3.4	15			9.8.5.1	3												
	44		50		62		49		40		48		52		40		43		22



Figure K
450
Total K
490

Judges Name	
Signature	Number

Flight # 21

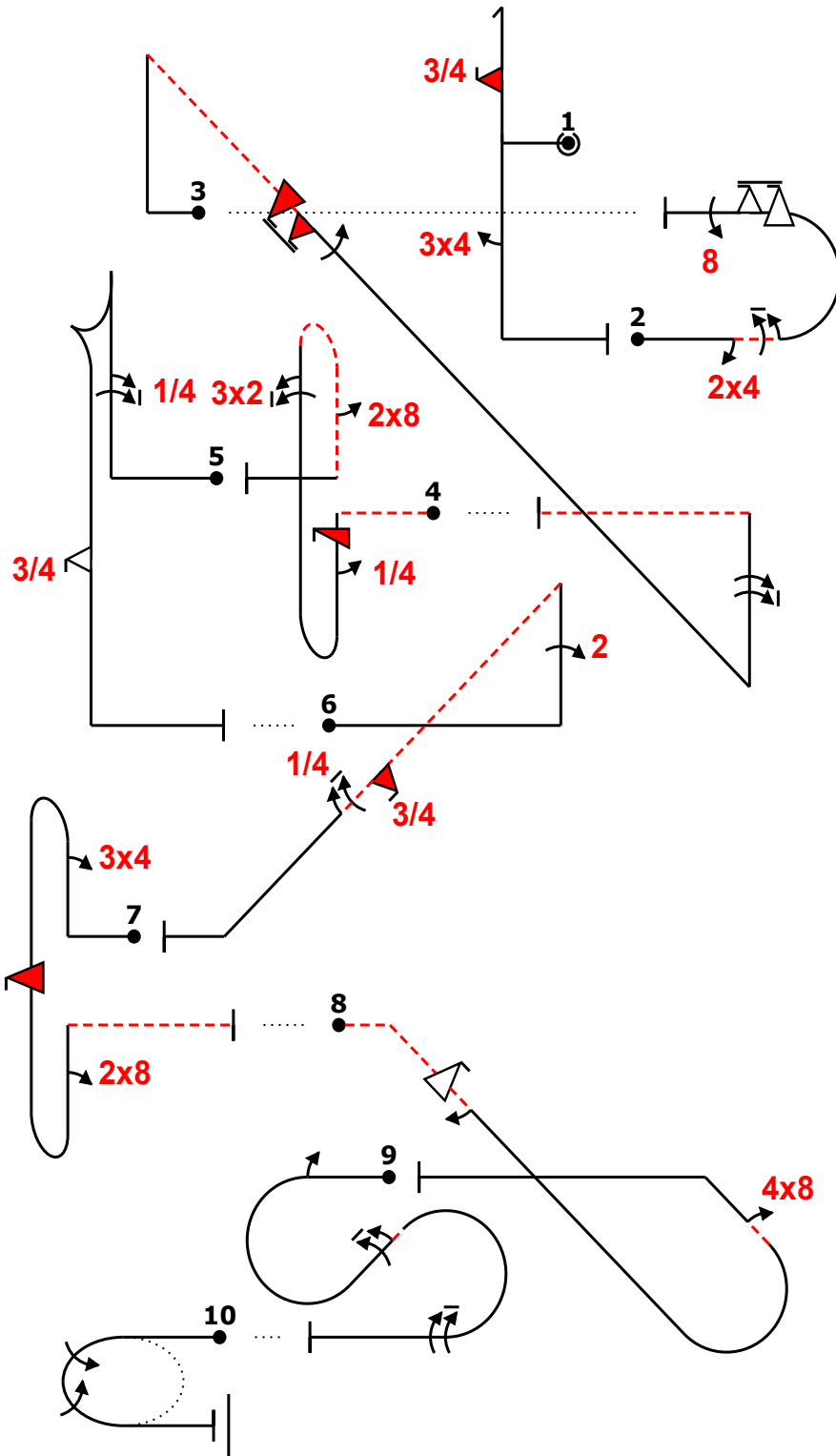
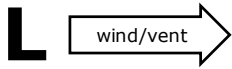

Fig	Grade	Pos	Remarks
1	.		
2	.		
3	.		
4	.		
5	.		
6	.		
7	.		
8	.		
9	.		
10	.		

Positioning 40	.
--------------------------	---

Too Low		Trg Violation	
Too High		Wing Rocks	
Interruptions		Disqual Fig	
Insertions		Other(note...)	

Fig 1 A	K	Fig 2 B	K	Fig 3	K	Fig 4 E	K	Fig 5	K	Fig 6 D	K	Fig 7	K	Fig 8 C	K	Fig 9	K	Fig 10	K
5.2.1.1	17	7.2.2.1	6	1.3.11.1	20	8.8.3.4	20	6.2.1.1	15	1.2.7.1	13	8.8.1.1	18	8.4.16.4	14	7.5.5.3	15	2.2.5.1	22
9.10.6.3	19	9.4.3.2	5	9.10.4.6	16	9.12.1.4	7	9.1.1.5	14	9.2.1.4	13	9.4.1.3	12	9.9.9.4	13	9.1.3.2	4		
9.4.5.3	8	9.1.3.6	10	9.1.4.4	8	9.1.5.1	2	9.9.5.3	11	9.10.4.3	13	9.10.10.4	15	9.1.4.2	4	9.1.2.6	12		
		9.9.3.6	14	9.1.1.8	18	9.2.1.6	17			9.1.4.5	9	9.8.1.1	7	9.8.2.2	9	9.1.3.8	12		
		9.8.3.4	15			9.8.5.1	3												
	44		50		62		49		40		48		52		40		43		22

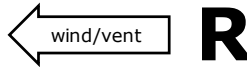

Figure K
 450
 Total K
 490

Judges Name	
Signature	Number

Flight # 22

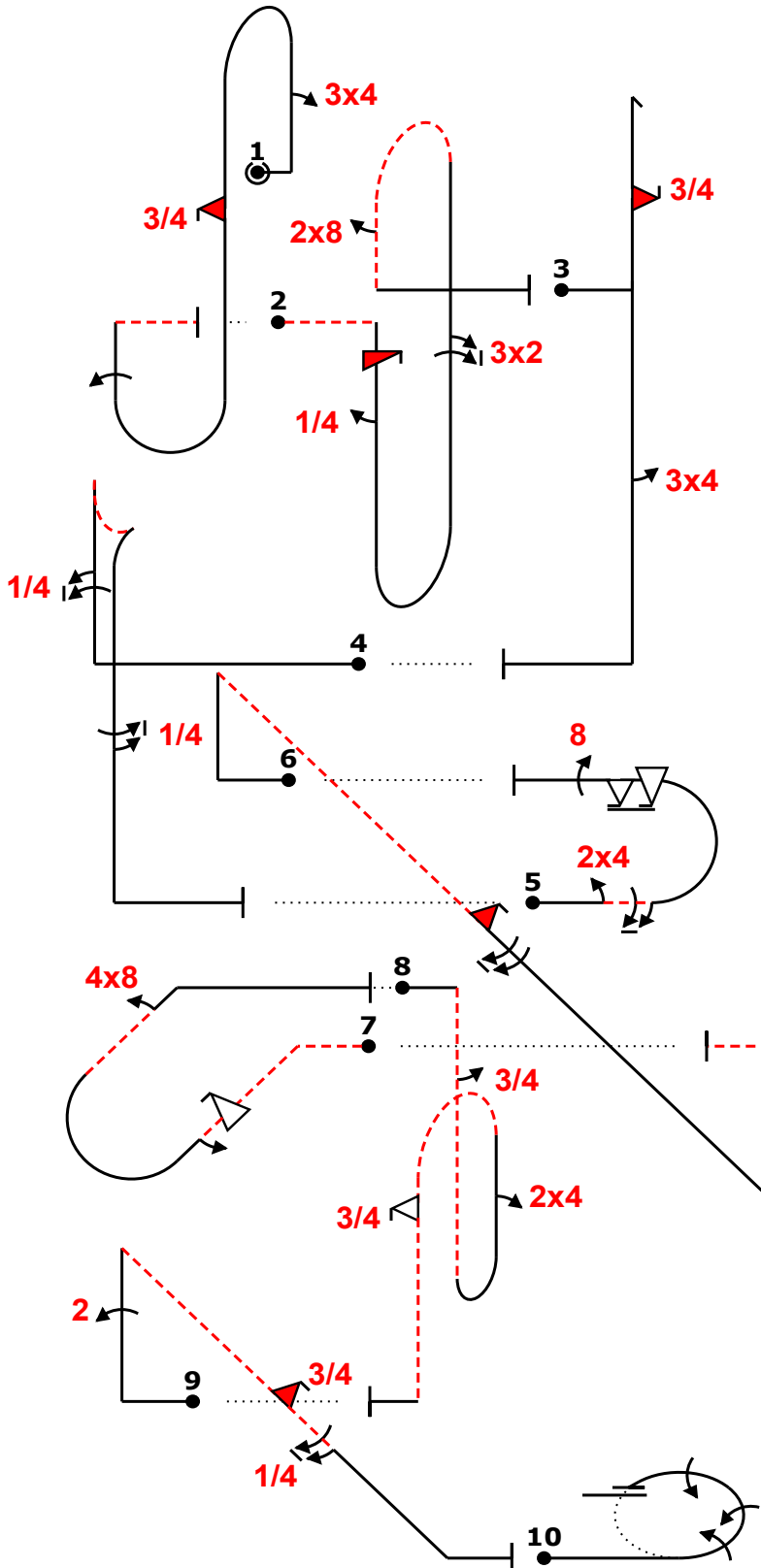

Fig	Grade	Pos	Remarks
1	.		
2	.		
3	.		
4	.		
5	.		
6	.		
7	.		
8	.		
9	.		
10	.		

Positioning 40	.
--------------------------	---

Too Low		Trg Violation	
Too High		Wing Rocks	
Interruptions		Disqual Fig	
Insertions		Other(note...)	

Fig 1	K	Fig 2 E	K	Fig 3 A	K	Fig 4	K	Fig 5 B	K	Fig 6	K	Fig 7 C	K	Fig 8	K	Fig 9 D	K	Fig 10	K
8.8.1.1	18	8.8.3.4	20	5.2.1.1	17	6.2.2.1	15	7.2.2.1	6	1.3.11.1	20	8.4.16.4	14	8.8.6.3	21	1.2.7.1	13	2.3.4.1	30
9.4.1.3	12	9.12.1.4	7	9.10.6.3	19	9.1.1.5	14	9.4.3.2	5	9.10.4.2	13	9.9.9.4	13	9.1.5.3	6	9.2.1.4	13		
9.10.10.3	15	9.1.5.1	2	9.4.5.3	8	9.1.5.5	9	9.1.3.6	10	9.1.4.8	12	9.1.4.2	4	9.4.1.2	9	9.10.4.3	13		
9.1.1.4	12	9.2.1.6	17					9.9.3.6	14			9.8.2.2	9	9.9.10.3	13	9.1.4.5	9		
		9.8.5.1	3					9.8.3.4	15										
	57		49		44		38		50		45		40		49		48		30



Figure K
 450
 Total K
 490

Judges Name	
Signature	Number

Flight # 22

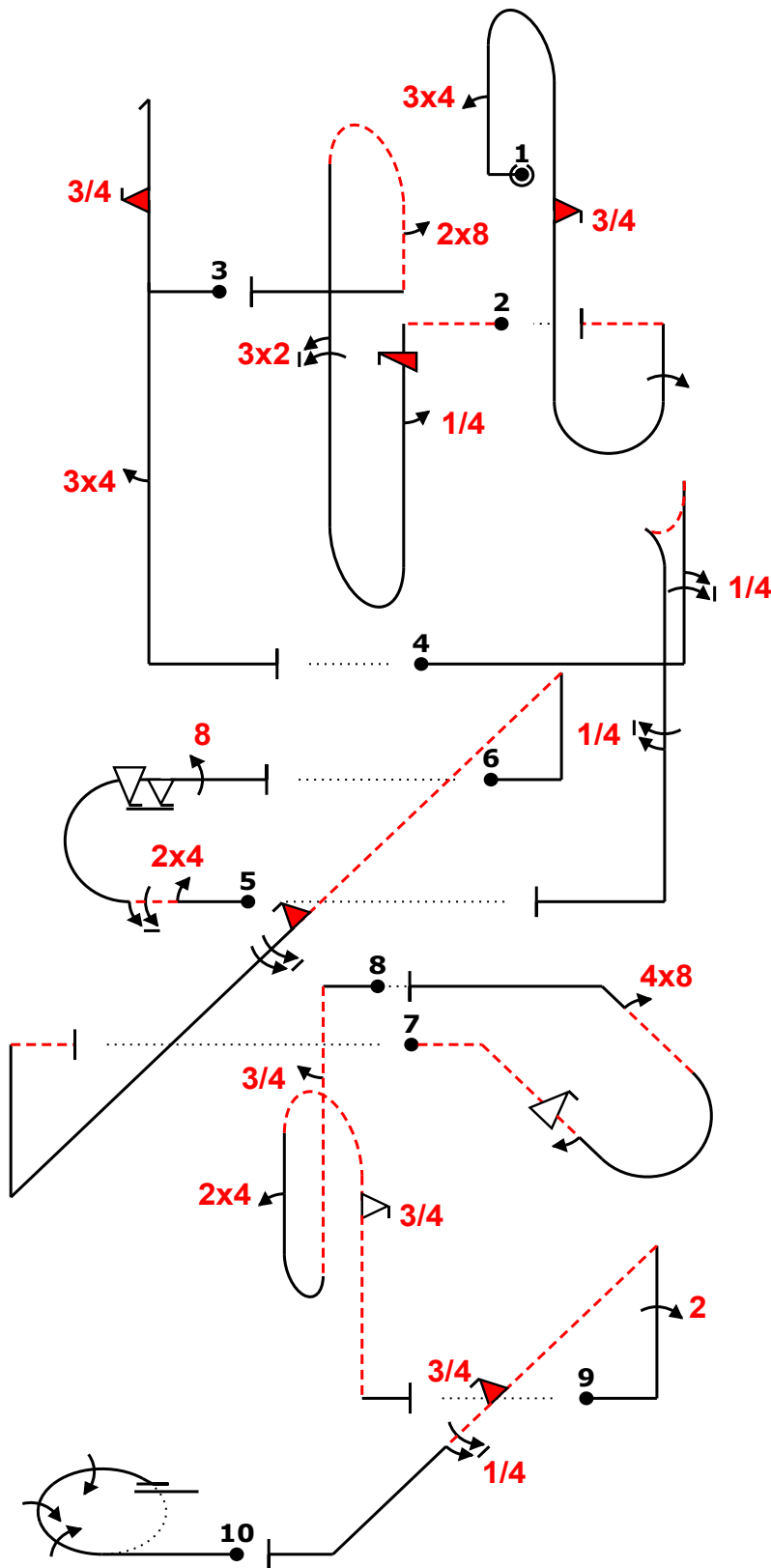
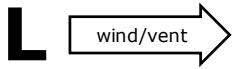

Fig	Grade	Pos	Remarks
1	.		
2	.		
3	.		
4	.		
5	.		
6	.		
7	.		
8	.		
9	.		
10	.		

Positioning 40	.
-------------------	---

Too Low		Trg Violation	
Too High		Wing Rocks	
Interruptions		Disqual Fig	
Insertions		Other(note...)	

Fig 1	K	Fig 2 E	K	Fig 3 A	K	Fig 4	K	Fig 5 B	K	Fig 6	K	Fig 7 C	K	Fig 8	K	Fig 9 D	K	Fig 10	K
8.8.1.1	18	8.8.3.4	20	5.2.1.1	17	6.2.2.1	15	7.2.2.1	6	1.3.11.1	20	8.4.16.4	14	8.8.6.3	21	1.2.7.1	13	2.3.4.1	30
9.4.1.3	12	9.12.1.4	7	9.10.6.3	19	9.1.1.5	14	9.4.3.2	5	9.10.4.2	13	9.9.9.4	13	9.1.5.3	6	9.2.1.4	13		
9.10.10.3	15	9.1.5.1	2	9.4.5.3	8	9.1.5.5	9	9.1.3.6	10	9.1.4.8	12	9.1.4.2	4	9.4.1.2	9	9.10.4.3	13		
9.1.1.4	12	9.2.1.6	17					9.9.3.6	14			9.8.2.2	9	9.9.10.3	13	9.1.4.5	9		
		9.8.5.1	3					9.8.3.4	15										
	57		49		44		38		50		45		40		49		48		30

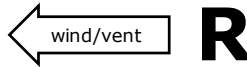

Figure K
450
Total K
490

Judges Name	
Signature	Number

Flight # 23

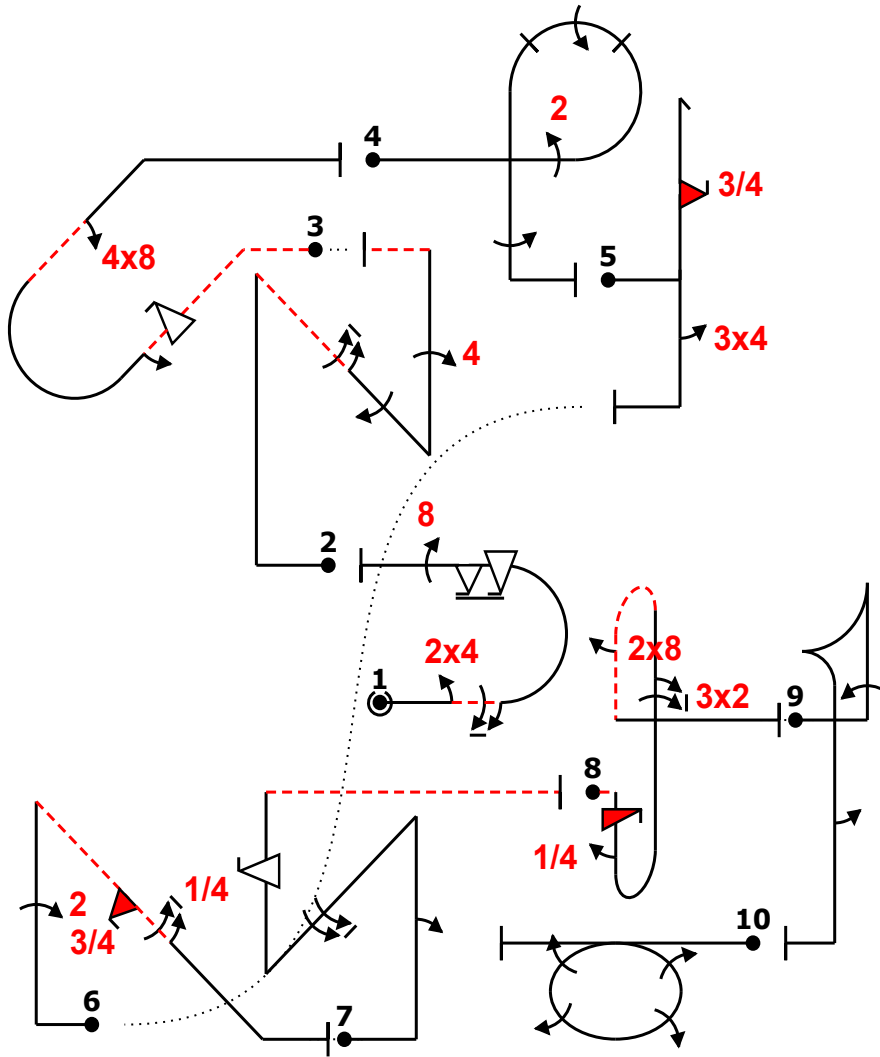

Fig	Grade	Pos	Remarks
1	.		
2	.		
3	.		
4	.		
5	.		
6	.		
7	.		
8	.		
9	.		
10	.		

Positioning 40	.
--------------------------	---

Too Low		Trg Violation	
Too High		Wing Rocks	
Interruptions		Disqual Fig	
Insertions		Other(note...)	

Fig 1 B	K	Fig 2	K	Fig 3 C	K	Fig 4	K	Fig 5 A	K	Fig 6 D	K	Fig 7	K	Fig 8 E	K	Fig 9	K	Fig 10	K
7.2.2.1	6	1.3.11.1	20	8.4.16.4	14	8.6.5.1	11	5.2.1.1	17	1.2.7.1	13	1.3.14.1	22	8.8.3.4	20	6.2.1.1	15	2.4.7.3	42
9.4.3.2	5	9.1.4.6	10	9.9.9.4	13	9.2.3.4	9	9.10.6.3	19	9.2.1.4	13	9.1.1.2	8	9.12.1.4	7	9.1.1.4	12		
9.1.3.6	10	9.1.4.4	8	9.1.4.2	4	9.1.3.4	8	9.4.5.3	8	9.10.4.3	13	9.1.4.8	12	9.1.5.1	2	9.1.5.2	4		
9.9.3.6	14	9.4.1.4	15	9.8.2.2	9	9.1.5.4	8			9.1.4.5	9	9.9.1.4	15	9.2.1.6	17				
9.8.3.4	15													9.8.5.1	3				
	50		53		40		36		44		48		57		49		31		42



Figure K
450
Total K
490

Judges Name	
Signature	Number

Flight # 23

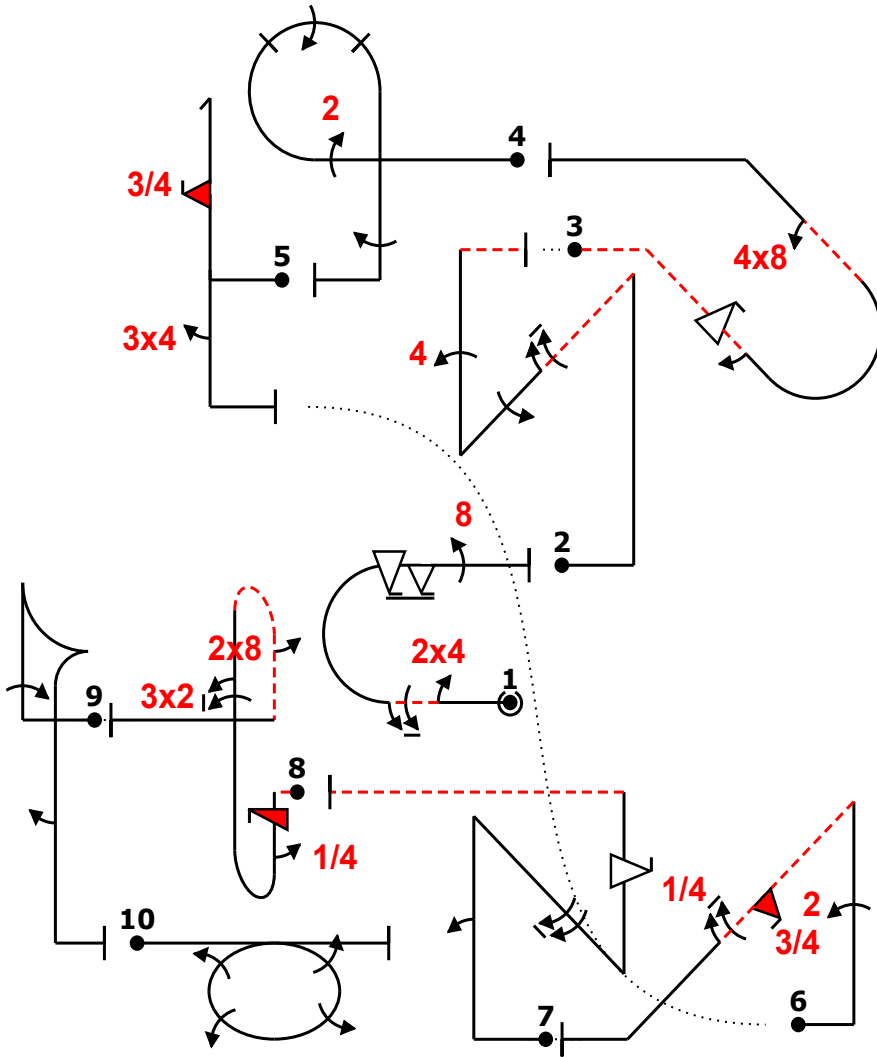
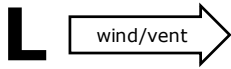

Fig	Grade	Pos	Remarks
1	.		
2	.		
3	.		
4	.		
5	.		
6	.		
7	.		
8	.		
9	.		
10	.		

Positioning 40	.
--------------------------	---

Too Low		Trg Violation	
Too High		Wing Rocks	
Interruptions		Disqual Fig	
Insertions		Other(note...)	

Fig 1 B	K	Fig 2	K	Fig 3 C	K	Fig 4	K	Fig 5 A	K	Fig 6 D	K	Fig 7	K	Fig 8 E	K	Fig 9	K	Fig 10	K
7.2.2.1	6	1.3.11.1	20	8.4.16.4	14	8.6.5.1	11	5.2.1.1	17	1.2.7.1	13	1.3.14.1	22	8.8.3.4	20	6.2.1.1	15	2.4.7.3	42
9.4.3.2	5	9.1.4.6	10	9.9.9.4	13	9.2.3.4	9	9.10.6.3	19	9.2.1.4	13	9.1.1.2	8	9.12.1.4	7	9.1.1.4	12		
9.1.3.6	10	9.1.4.4	8	9.1.4.2	4	9.1.3.4	8	9.4.5.3	8	9.10.4.3	13	9.1.4.8	12	9.1.5.1	2	9.1.5.2	4		
9.9.3.6	14	9.4.1.4	15	9.8.2.2	9	9.1.5.4	8			9.1.4.5	9	9.9.1.4	15	9.2.1.6	17				
9.8.3.4	15													9.8.5.1	3				
	50		53		40		36		44		48		57		49		31		42

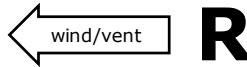

Figure K
450
Total K
490

Judges Name	
Signature	Number

Flight #
24

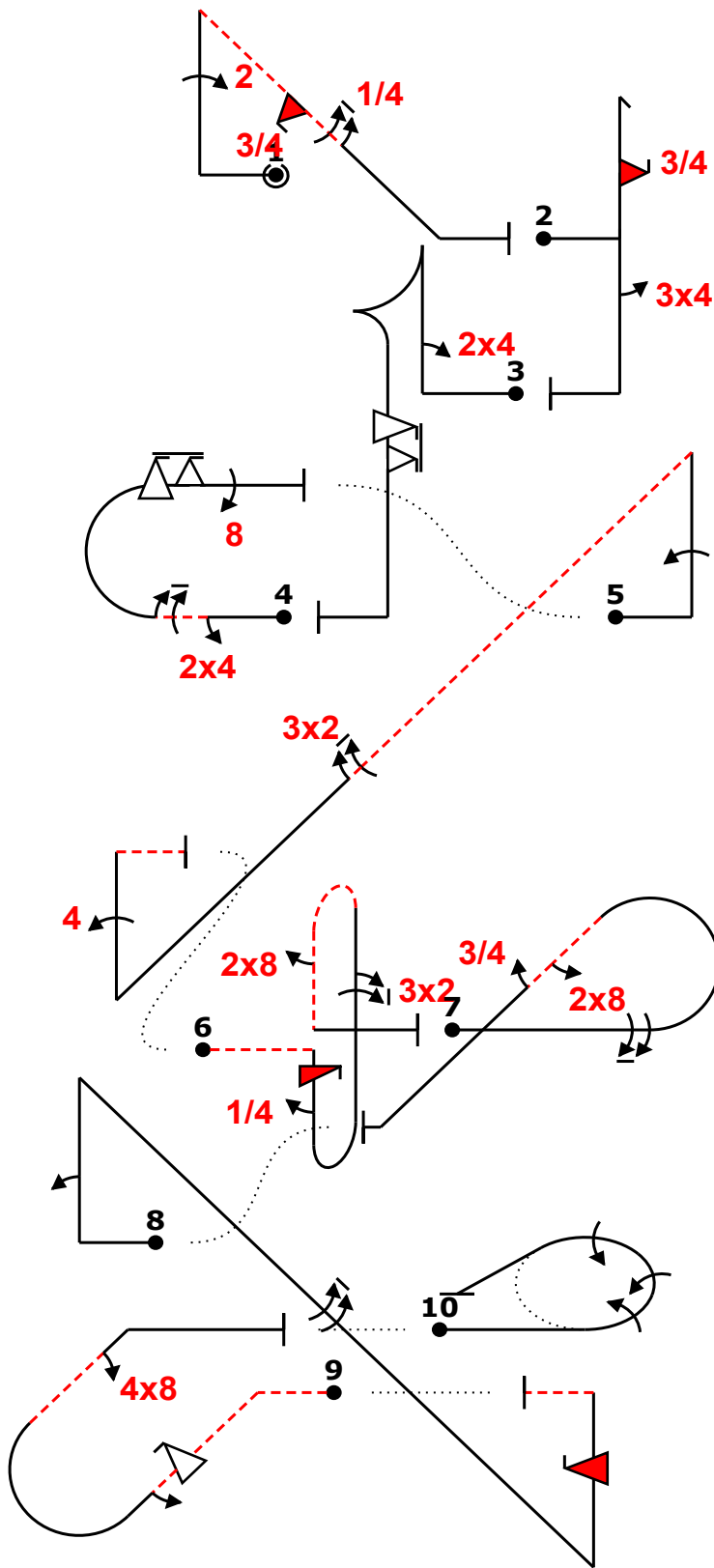

Fig	Grade	Pos	Remarks
1	.		
2	.		
3	.		
4	.		
5	.		
6	.		
7	.		
8	.		
9	.		
10	.		

Positioning
40

Too Low		Trg Violation	
Too High		Wing Rocks	
Interruptions		Disqual Fig	
Insertions		Other(note...)	

Fig 1 D	K	Fig 2 A	K	Fig 3	K	Fig 4 B	K	Fig 5	K	Fig 6 E	K	Fig 7	K	Fig 8	K	Fig 9 C	K	Fig 10	K
1.2.7.1	13	5.2.1.1	17	6.2.1.1	15	7.2.2.1	6	1.3.11.1	20	8.8.3.4	20	8.5.6.1	10	1.3.14.1	22	8.4.16.4	14	2.3.4.1	30
9.2.1.4	13	9.10.6.3	19	9.4.1.2	9	9.4.3.2	5	9.1.1.4	12	9.12.1.4	7	9.1.3.8	12	9.1.1.2	8	9.9.9.4	13		
9.10.4.3	13	9.4.5.3	8	9.9.5.6	14	9.1.3.6	10	9.2.4.6	12	9.1.5.1	2	9.8.4.1	3	9.1.4.8	12	9.1.4.2	4		
9.1.4.5	9					9.9.3.6	14	9.4.1.4	15	9.2.1.6	17	9.1.4.3	6	9.10.6.4	19	9.8.2.2	9		
						9.8.3.4	15			9.8.5.1	3								
	48		44		38		50		59		49		31		61		40		30



Figure K
450
Total K
490

Judges Name	
Signature	Number

Flight # 24

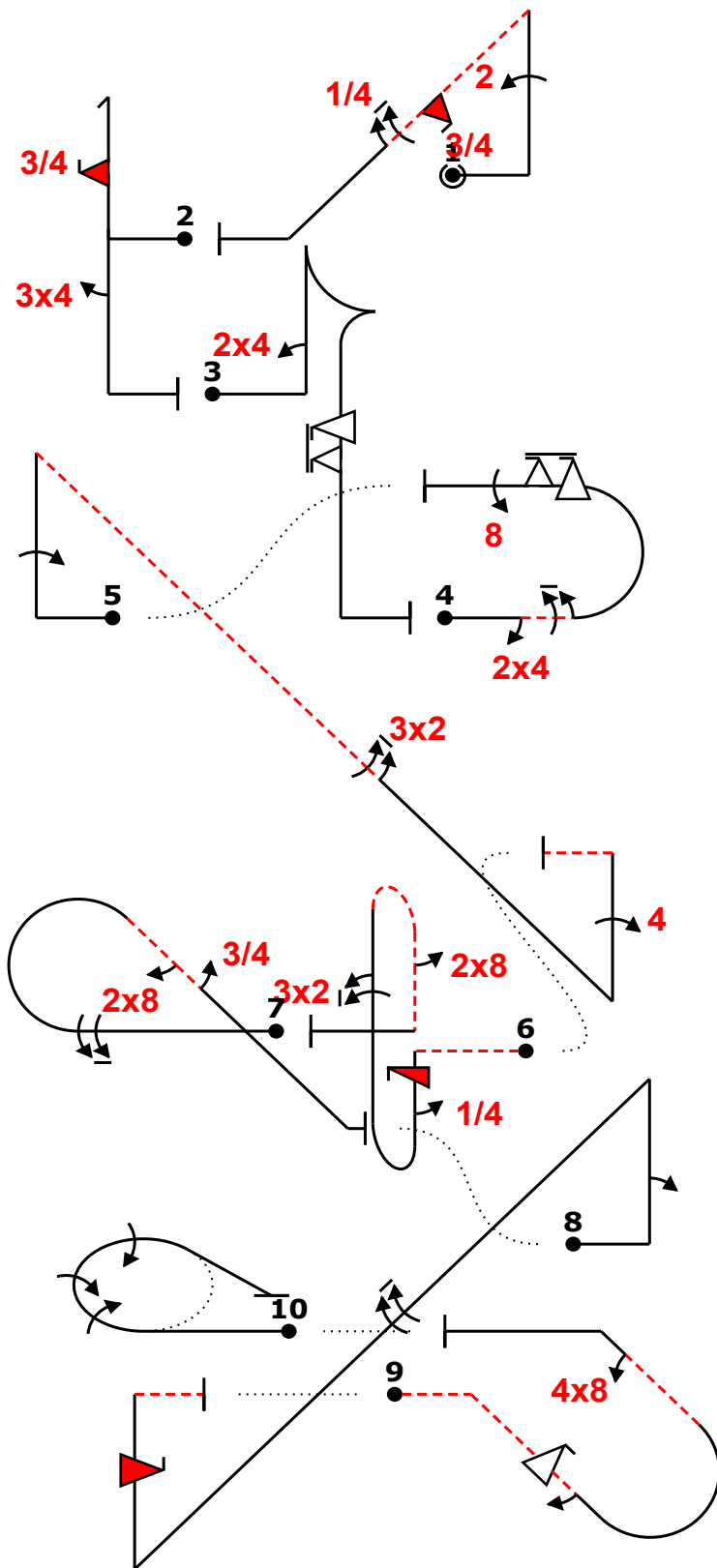
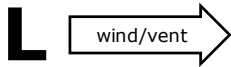

Fig	Grade	Pos	Remarks
1	.		
2	.		
3	.		
4	.		
5	.		
6	.		
7	.		
8	.		
9	.		
10	.		

Positioning 40	.
-------------------	---

Too Low		Trg Violation	
Too High		Wing Rocks	
Interruptions		Disqual Fig	
Insertions		Other(note...)	

Fig 1 D	K	Fig 2 A	K	Fig 3	K	Fig 4 B	K	Fig 5	K	Fig 6 E	K	Fig 7	K	Fig 8	K	Fig 9 C	K	Fig 10	K
1.2.7.1	13	5.2.1.1	17	6.2.1.1	15	7.2.2.1	6	1.3.11.1	20	8.8.3.4	20	8.5.6.1	10	1.3.14.1	22	8.4.16.4	14	2.3.4.1	30
9.2.1.4	13	9.10.6.3	19	9.4.1.2	9	9.4.3.2	5	9.1.1.4	12	9.12.1.4	7	9.1.3.8	12	9.1.1.2	8	9.9.9.4	13		
9.10.4.3	13	9.4.5.3	8	9.9.5.6	14	9.1.3.6	10	9.2.4.6	12	9.1.5.1	2	9.8.4.1	3	9.1.4.8	12	9.1.4.2	4		
9.1.4.5	9					9.9.3.6	14	9.4.1.4	15	9.2.1.6	17	9.1.4.3	6	9.10.6.4	19	9.8.2.2	9		
	48		44		38	9.8.3.4	15		59	9.8.5.1	3								30
							50				49		31		61		40		30