

PROPOSAL A



CIVA	Unlimited	SEP 23
Programme2	EAC 23 PAVULLO, IT	

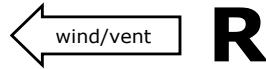

Figure K
460
Total K
500

Judges Name	
Signature	Number

Flight #

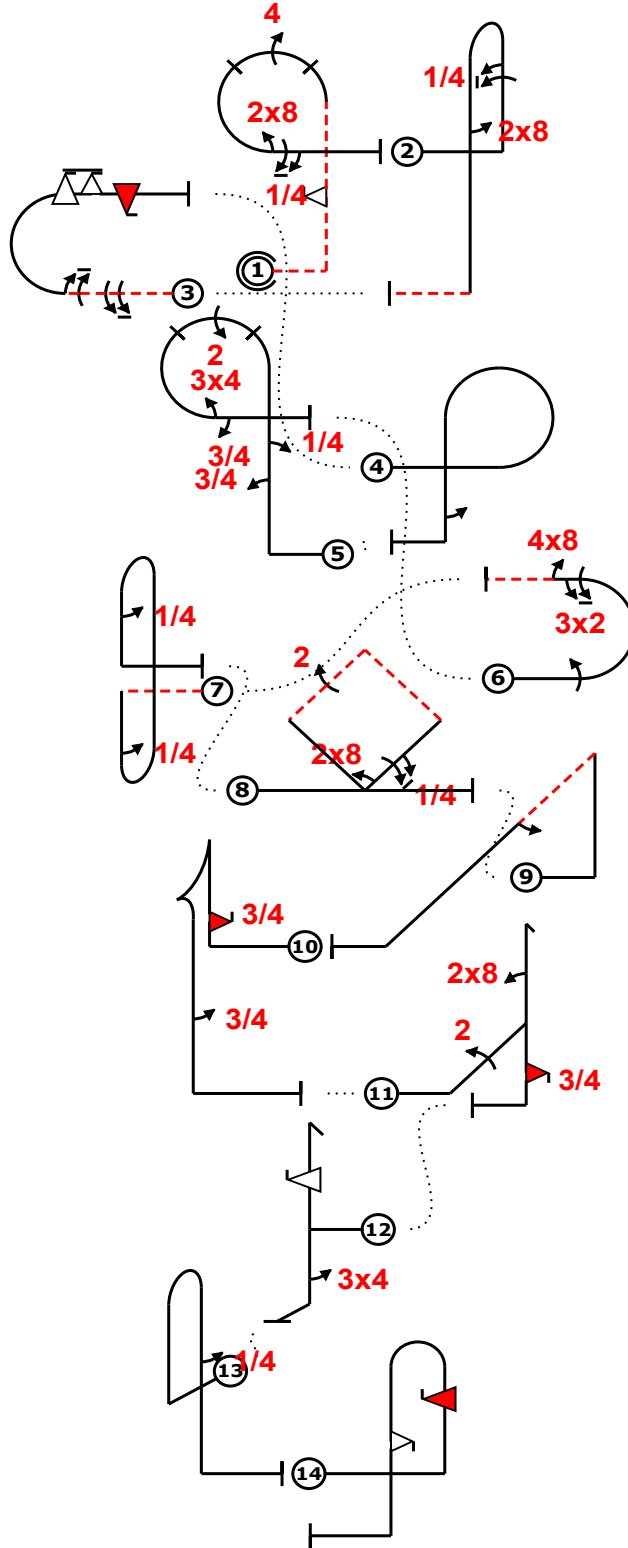

Fig	Grade	Pos	Remarks
1	.		
2	.		
3	.		
4	.		
5	.		
6	.		
7	.		
8	.		
9	.		
10	.		
11	.		
12	.		
13	.		
14	.		

Positioning
40

Too Low		Trg Violation	
Too High		Wing Rocks	
Interruptions		Disqual Fig	
Insertions		Other(note...)	

"@D" -. '2f'rp(,44)8,5 "@H" 5b8... (-11,0) "@B" -9,6mf,if (10,22) "@L" p2 (0,1) "@G" . '3'' ,4rp(22) 34,3 (10,21) "@I" '1m32,48~ (-16,9) "@L" -41bb4 (-1,10) "@J" '8,5dq,22 (0,7) "@L" k2.. "@F" '3'+, 3ifta3.' (2,0) "@E" 22dh(28)3if (-3,10) "@C" fh34 (0,2) "@L" b4.' "@A" +ifb2f. eu eu eu eu eu eu e u eu eu eu eu eu

Fig 1 D	K	Fig 2 H	K	Fig 3 B	K	Fig 4 L	K	Fig 5 G	K	Fig 6 I	K	Fig 7 L	K	Fig 8 J	K	Fig 9 L	K	Fig 10 F	K	Fig 11 E	K	Fig 12 C	K	Fig 13 L	K	Fig 14 A	K
8.6.3.2	13	8.4.2.1	14	7.2.4.2	6	8.6.5.1	11	8.6.1.1	11	7.2.1.1	6	8.8.1.4	18	7.4.5.1	15	1.2.7.1	13	6.2.1.1	15	5.3.1.1	18	5.2.1.1	17	8.4.1.1	13	8.4.1.1	13
9.9.6.2	17	9.1.1.5	14	9.1.3.8	12	9.1.5.2	4	9.1.1.3	10	9.1.3.4	8	9.1.5.1	2	9.8.2.1	5	9.1.4.2	4	9.10.6.3	19	9.2.2.4	11	9.9.1.4	15	9.1.5.1	2	9.10.6.4	19
9.4.3.4	11	9.8.5.1	3	9.1.3.6	10			9.1.1.1	6	9.2.3.6	12	9.1.5.1	2	9.1.2.5	11			9.1.5.3	6	9.8.1.1	7	9.4.5.3	8			9.9.5.2	11
9.8.3.1	3			9.9.3.6	14			9.2.3.4	9	9.8.3.2	7			9.2.4.4	9					9.10.5.3	13						
9.1.3.5	9			9.10.8.4	15			9.4.3.3	8																		
	53		31		57		6		50		33		6		40		6		40		49		40		6		43

Pilot: PROPOSAL A

A/C:

Team: FRA

PROPOSAL A



CIVA Unlimited SEP 23
 Programme2 EAC 23 PAVULLO, IT

Figure K
460
 Total K
500

Judges Name		Flight #
Signature	Number	

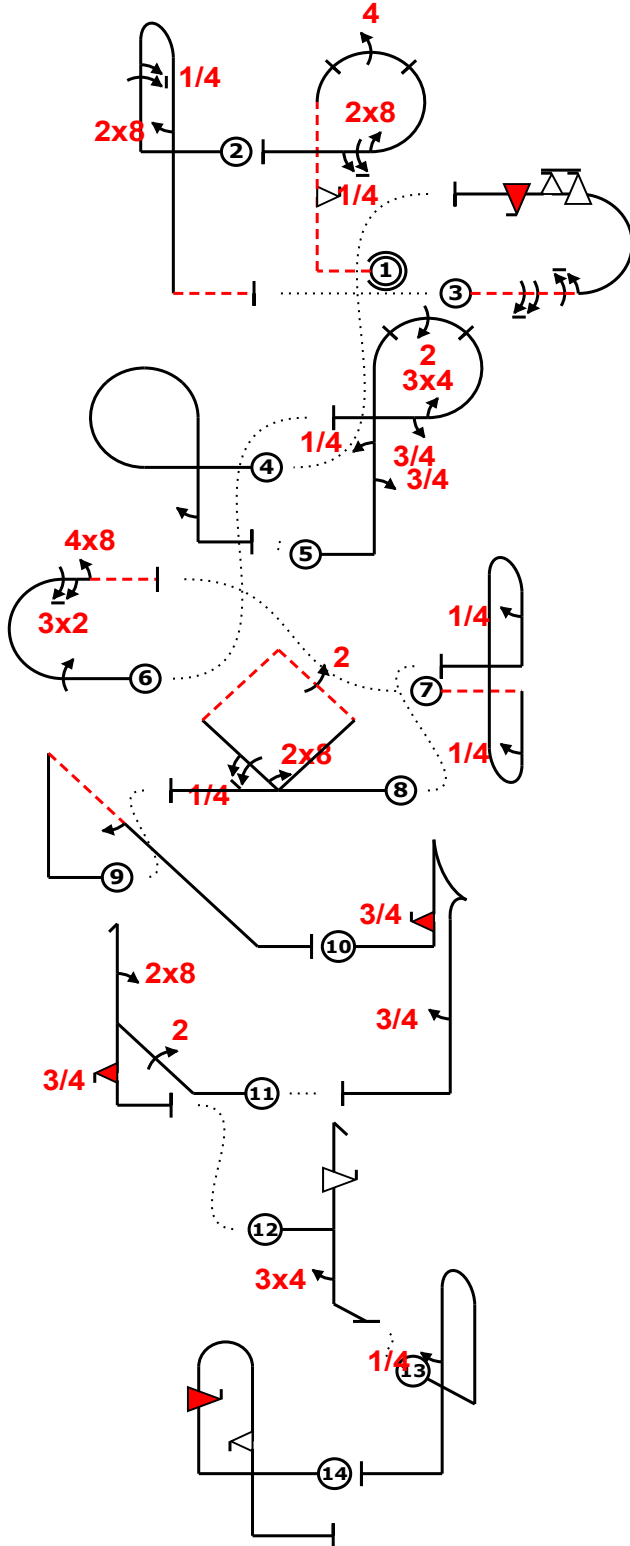
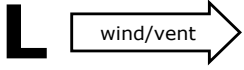

Fig	Grade	Pos	Remarks
1	.		
2	.		
3	.		
4	.		
5	.		
6	.		
7	.		
8	.		
9	.		
10	.		
11	.		
12	.		
13	.		
14	.		

Positioning
40

Too Low		Trg Violation	
Too High		Wing Rocks	
Interruptions		Disqual Fig	
Insertions		Other(note...)	

"@D" -. '2f'rp(,44)8,5 "@H" 5b8... (-11,0) "@B" -9,6mf,if (10,22) "@L" p2 (0,1) "@G" . '3'' ,4rp(22) 34,3 (10,21) "@I" '1m32,48~ (-16,9) "@L" -41bb4 (-1,10) "@J" '8,5dq,22 (0,7) "@L" k2.. "@F" '+, 3ifta3.' (2,0) "@E" 22dh(28)3if (-3,10) "@C" fh34 (0,2) "@L" b4.' "@A" +ifb2f. eu eu eu eu eu eu e u eu eu eu eu eu

Fig 1 D	K	Fig 2 H	K	Fig 3 B	K	Fig 4 L	K	Fig 5 G	K	Fig 6 I	K	Fig 7 L	K	Fig 8 J	K	Fig 9 L	K	Fig 10 F	K	Fig 11 E	K	Fig 12 C	K	Fig 13 L	K	Fig 14 A	K
8.6.3.2	13	8.4.2.1	14	7.2.4.2	6	8.6.5.1	11	8.6.1.1	11	7.2.1.1	6	8.8.1.4	18	7.4.5.1	15	1.2.7.1	13	6.2.1.1	15	5.3.1.1	18	5.2.1.1	17	8.4.1.1	13	8.4.1.1	13
9.9.6.2	17	9.1.1.5	14	9.1.3.8	12	9.1.5.2	4	9.1.1.3	10	9.1.3.4	8	9.1.5.1	2	9.8.2.1	5	9.1.4.2	4	9.10.6.3	19	9.2.2.4	11	9.9.1.4	15	9.1.5.1	2	9.10.6.4	19
9.4.3.4	11	9.8.5.1	3	9.1.3.6	10			9.1.1.1	6	9.2.3.6	12	9.1.5.1	2	9.1.2.5	11			9.1.5.3	6	9.8.1.1	7	9.4.5.3	8			9.9.5.2	11
9.8.3.1	3			9.9.3.6	14			9.2.3.4	9	9.8.3.2	7			9.2.4.4	9					9.10.5.3	13						
9.1.3.5	9			9.10.8.4	15			9.4.3.3	8																		
	53		31		57		6		50		33		6		40		6		40		49		40		6		43

Pilot: **PROPOSAL A**

A/C:

Team: **FRA**

PROPOSAL B



CIVA Unlimited SEP 2023
 Programme2 EAC 23 PAVULLO, IT

← wind/vent **R**

Figure K
460
 Total K
500

Judges Name	
Signature	Number

Flight #

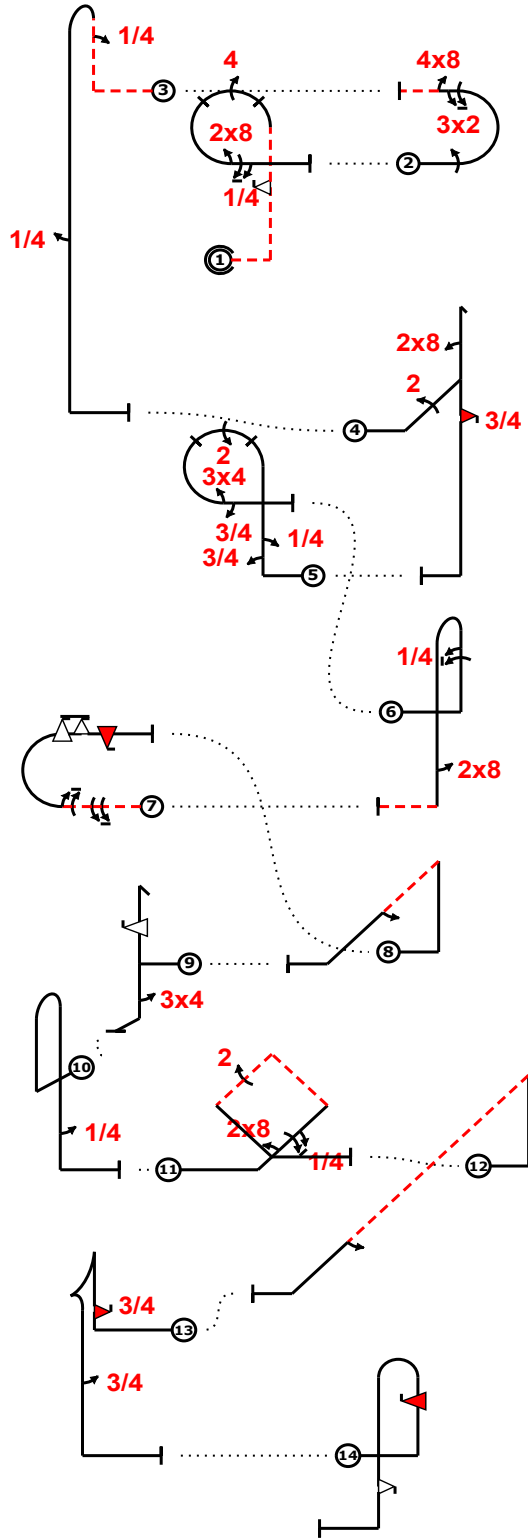

Fig	Grade	Pos	Remarks
1	.		
2	.		
3	.		
4	.		
5	.		
6	.		
7	.		
8	.		
9	.		
10	.		
11	.		
12	.		
13	.		
14	.		

Positioning **40** .

Too Low		Trg Violation	
Too High		Wing Rocks	
Interruptions		Disqual Fig	
Insertions		Other(note...)	

"@D" --.2frp(,44)8,5 (6,0) "I" 1m32,48- (-20,0) "L" -,4b.....',4..... (19,2) "E" 22dh(8)3if....
 . (-7,0) "G" 3,4''rp(22)34,3 (6,23) "H" 5b...'8- (-19,0) "B" -9,6m6f,if (20,24) "L" k2 (-6,0) "
 @C" fh34 (0,2) "L" b...'4 (1,0) "J" `8`',5dq,22 (9,1) "L" k.....2 (-3,4) "F" ,3ifta3.. (15,0)
 "A" ifb..2f eu eu eu

Fig 1 D	K	Fig 2 I	K	Fig 3 L	K	Fig 4 E	K	Fig 5 G	K	Fig 6 H	K	Fig 7 B	K	Fig 8 L	K	Fig 9 C	K	Fig 10 L	K	Fig 11 J	K	Fig 12 L	K	Fig 13 F	K	Fig 14 A	K
8.6.3.2	13	7.2.1.1	6	8.4.4.2	14	5.3.1.1	18	8.6.1.1	11	8.4.2.1	14	7.2.4.2	6	1.2.7.1	13	5.2.1.1	17	8.4.1.1	13	7.4.5.1	15	1.2.7.1	13	6.2.1.1	15	8.4.1.1	13
9.9.6.2	17	9.1.3.4	8	9.1.1.1	6	9.2.2.4	11	9.1.1.3	10	9.1.1.5	14	9.1.3.8	12	9.1.4.2	4	9.9.1.4	15	9.1.5.1	2	9.8.2.1	5	9.1.4.2	4	9.10.6.3	19	9.10.6.4	19
9.4.3.4	11	9.2.3.6	12	9.1.5.1	2	9.8.1.1	7	9.1.1.1	6	9.8.5.1	3	9.1.3.6	10			9.4.5.3	8			9.1.2.5	11			9.1.5.3	6	9.9.5.2	11
9.8.3.1	3	9.8.3.2	7			9.10.5.3	13	9.2.3.4	9			9.9.3.6	14							9.2.4.4	9						
9.1.3.5	9							9.4.3.3	8			9.10.8.4	15														
	53		33		6		49		50		31		57		6		40		6		40		6		40		43

Pilot: **PROBOSAL B**

A/C:

Team: **FRA**

PROPOSAL B



CIVA Unlimited SEP 2023
 Programme2 EAC 23 PAVULLO, IT

Figure K
460
 Total K
500

Judges Name		Flight #
Signature	Number	

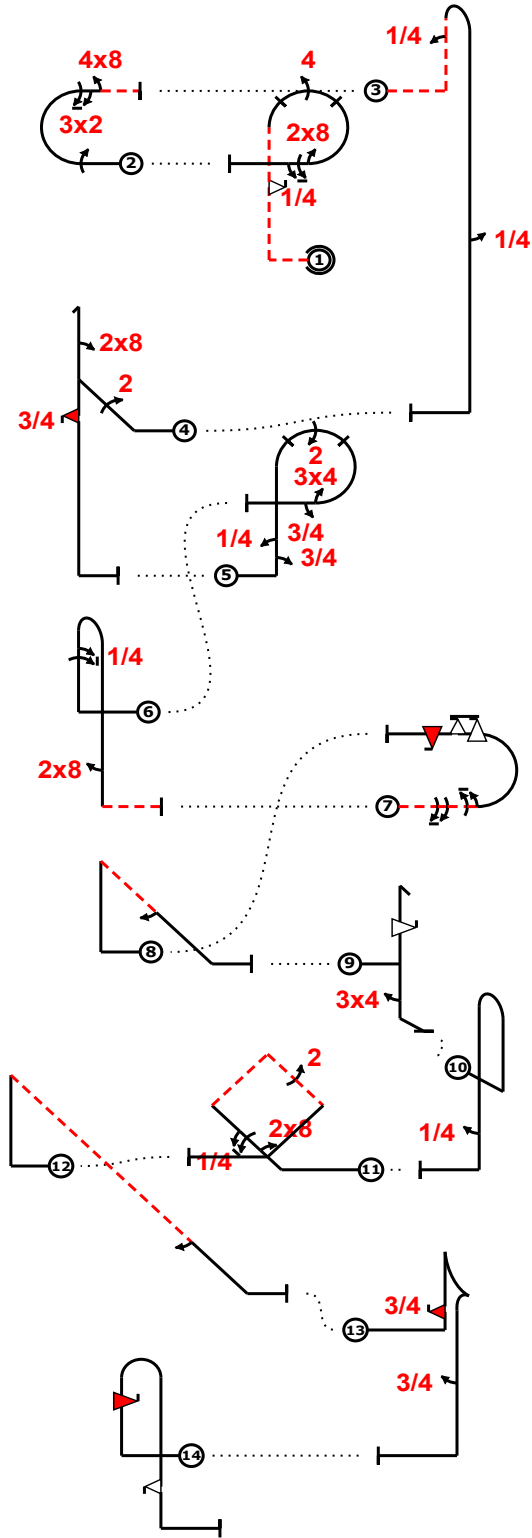
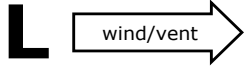

Fig	Grade	Pos	Remarks
1	.		
2	.		
3	.		
4	.		
5	.		
6	.		
7	.		
8	.		
9	.		
10	.		
11	.		
12	.		
13	.		
14	.		

Positioning
40 .

Too Low		Trg Violation	
Too High		Wing Rocks	
Interruptions		Disqual Fig	
Insertions		Other(note...)	

"@D" --.2frp(,44)8,5 (6,0) "I" 1m32,48- (-20,0) "@L" -,4b.....',4..... (19,2) "E" 22dh(8)3if....
 . (-7,0) "G" 3,4''rp(22)34,3 (6,23) "H" 5b..'8- (-19,0) "B" -9,6mf,if (20,24) "L" k2 (-6,0) "
 @C" fh34 (0,2) "L" b..'4 (1,0) "J" `8`',5dq,22 (9,1) "L" k.....2 (-3,4) "F" ,3ifta3.. (15,0)
 "A" ifb..2f eu eu eu

Fig 1 D	K	Fig 2 I	K	Fig 3 L	K	Fig 4 E	K	Fig 5 G	K	Fig 6 H	K	Fig 7 B	K	Fig 8 L	K	Fig 9 C	K	Fig 10 L	K	Fig 11 J	K	Fig 12 L	K	Fig 13 F	K	Fig 14 A	K
8.6.3.2	13	7.2.1.1	6	8.4.4.2	14	5.3.1.1	18	8.6.1.1	11	8.4.2.1	14	7.2.4.2	6	1.2.7.1	13	5.2.1.1	17	8.4.1.1	13	7.4.5.1	15	1.2.7.1	13	6.2.1.1	15	8.4.1.1	13
9.9.6.2	17	9.1.3.4	8	9.1.1.1	6	9.2.2.4	11	9.1.1.3	10	9.1.1.5	14	9.1.3.8	12	9.1.4.2	4	9.9.1.4	15	9.1.5.1	2	9.8.2.1	5	9.1.4.2	4	9.10.6.3	19	9.10.6.4	19
9.4.3.4	11	9.2.3.6	12	9.1.5.1	2	9.8.1.1	7	9.1.1.1	6	9.8.5.1	3	9.1.3.6	10			9.4.5.3	8			9.1.2.5	11			9.1.5.3	6	9.9.5.2	11
9.8.3.1	3	9.8.3.2	7			9.10.5.3	13	9.2.3.4	9			9.9.3.6	14							9.2.4.4	9						
9.1.3.5	9							9.4.3.3	8			9.10.8.4	15														
	53		33		6		49		50		31		57		6		40		6		40		6		40		43

Pilot: **PROBOSAL B**

A/C:

Team: **FRA**

PROPOSAL C



CIVA	Unlimited	09/2023
Programme2		EAC2023

Figure K
460
Total K
500

Judges Name	
Signature	Number

Flight #

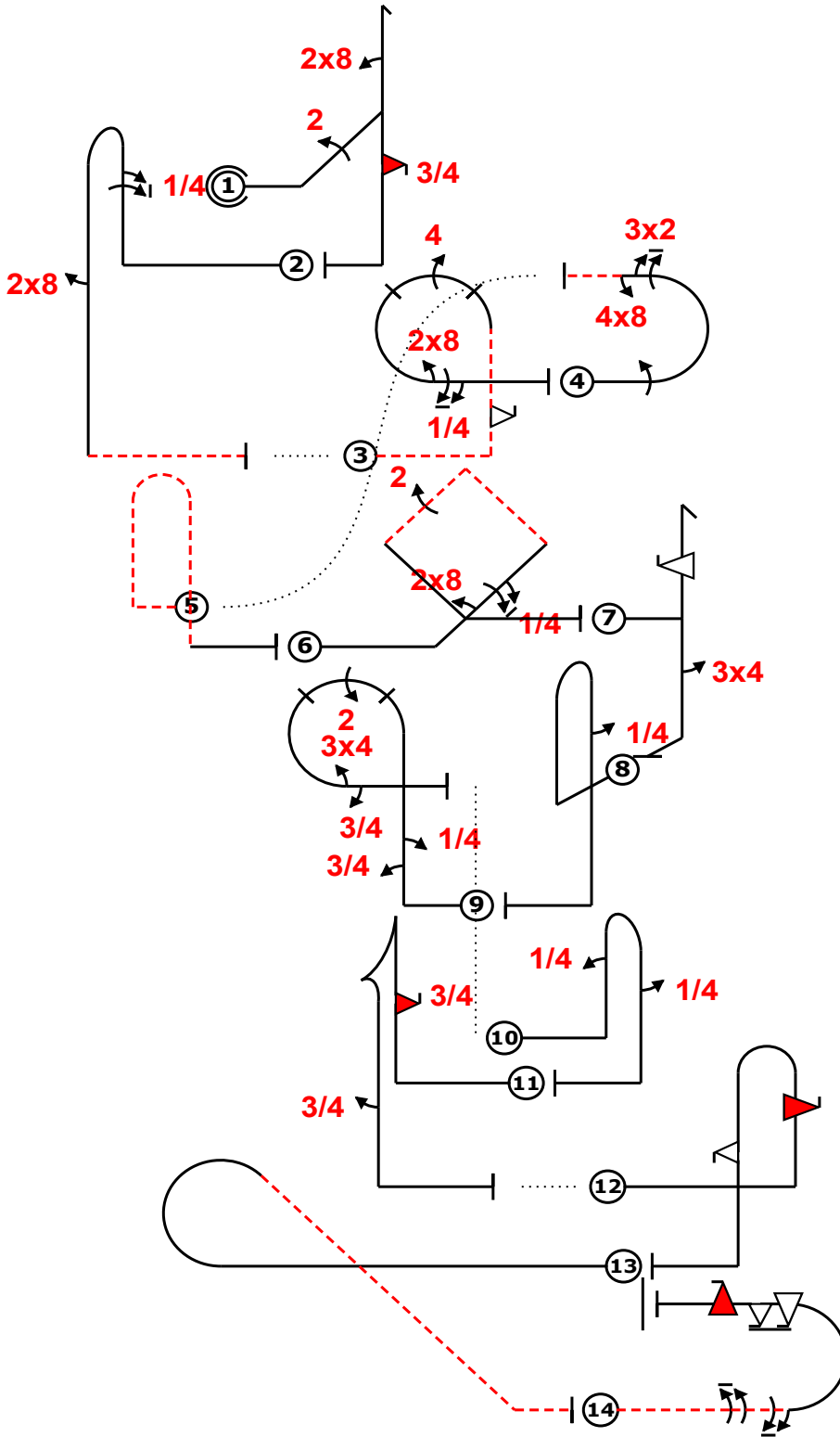
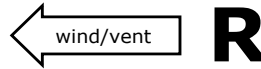

Fig	Grade	Pos	Remarks
1	.		
2	.		
3	.		
4	.		
5	.		
6	.		
7	.		
8	.		
9	.		
10	.		
11	.		
12	.		
13	.		
14	.		

Positioning	40	.
-------------	----	---

Too Low		Trg Violation	
Too High		Wing Rocks	
Interruptions		Disqual Fig	
Insertions		Other(note...)	

"@E" 22dh(8)3if.' " @H" ~+5b.,8..... (4,0) "@D" ~-',2frp(,44)8,5 " @I" 1m,32,48- (-22,25) "@L" ~-pb' "@J" 8,5dq,22 " @C" fh34. " @L" b`4... " @G" '3',4'rp(22)34,3 [0,19] "@L" /4b`4. " @F" /.' ,3ifta,3.' (4,0) "@A" ++,ifb,2f.' "@L"c..... " @B" -. '9,6m6f,if

Fig 1 E	K	Fig 2 H	K	Fig 3 D	K	Fig 4 I	K	Fig 5 L	K	Fig 6 J	K	Fig 7 C	K	Fig 8 L	K	Fig 9 G	K	Fig 10 L	K	Fig 11 F	K	Fig 12 A	K	Fig 13 L	K	Fig 14 B	K
5.3.1.1	18	8.4.2.1	14	8.6.3.2	13	7.2.1.1	6	8.4.2.2	17	7.4.5.1	15	5.2.1.1	17	8.4.1.1	13	8.6.1.1	11	8.4.1.1	13	6.2.1.1	15	8.4.1.1	13	8.5.5.1	10	7.2.4.2	6
9.2.2.4	11	9.1.1.5	14	9.9.6.2	17	9.1.3.4	8			9.8.2.1	5	9.9.1.4	15	9.1.5.1	2	9.1.1.3	10	9.1.1.1	6	9.10.6.3	19	9.10.6.4	19			9.1.3.8	12
9.8.1.1	7	9.8.5.1	3	9.4.3.4	11	9.2.3.6	12			9.1.2.5	11	9.4.5.3	8			9.1.1.1	6	9.1.5.1	2	9.1.5.3	6	9.9.5.2	11			9.1.3.6	10
9.10.5.3	13			9.8.3.1	3	9.8.3.2	7			9.2.4.4	9					9.2.3.4	9									9.9.3.6	14
				9.1.3.5	9											9.4.3.3	8									9.10.8.4	15
	49		31		53		33		6		40		40		6		50		6		40		43		6		57

Pilot: PROPOSAL C

A/C:

Team: GER

PROPOSAL C



CIVA	Unlimited	09/2023
Programme2		EAC2023

Figure K
460
Total K
500

Judges Name		Flight #
Signature	Number	

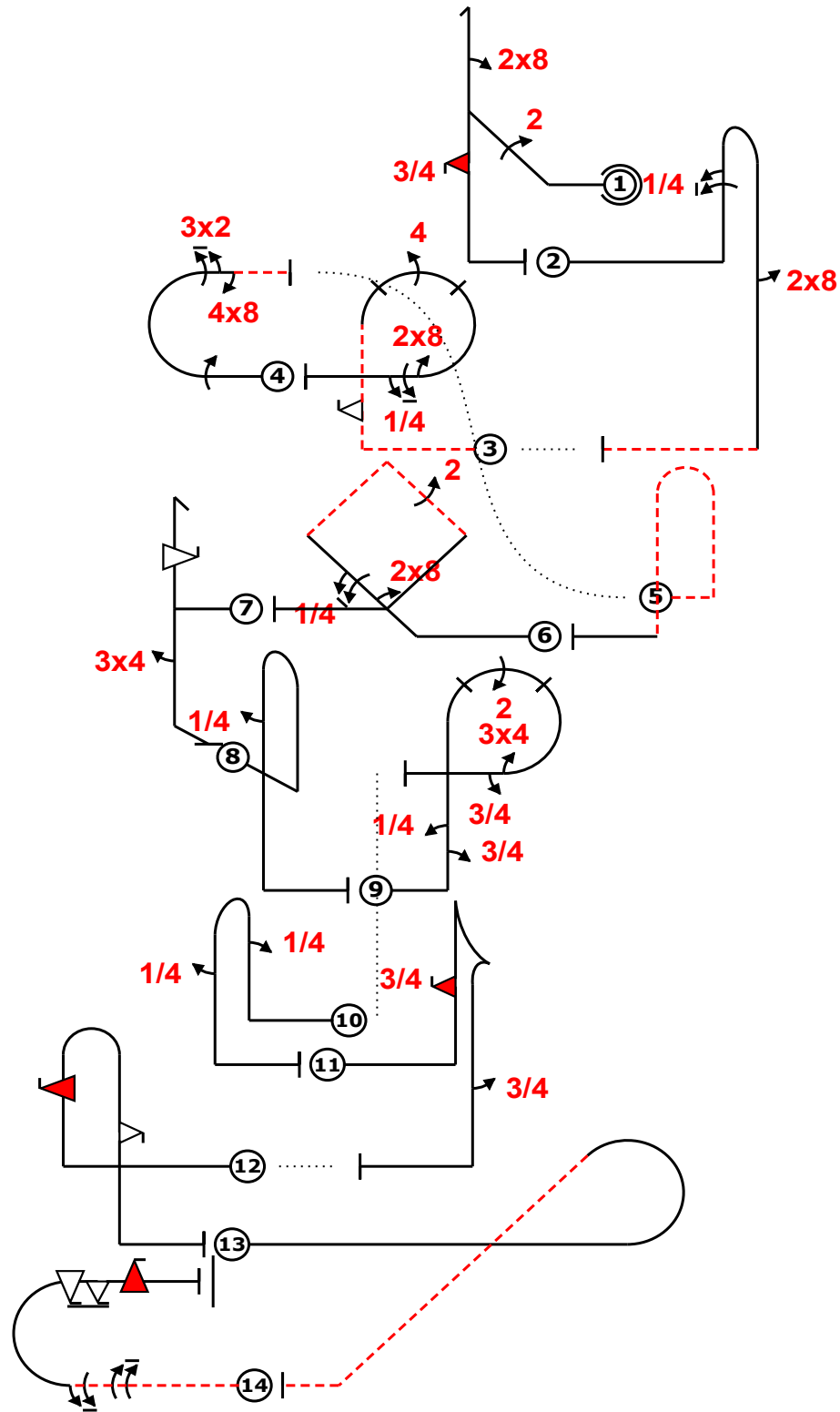
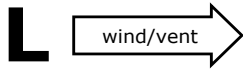

Fig	Grade	Pos	Remarks
1	.		
2	.		
3	.		
4	.		
5	.		
6	.		
7	.		
8	.		
9	.		
10	.		
11	.		
12	.		
13	.		
14	.		

Positioning
40

Too Low		Trg Violation	
Too High		Wing Rocks	
Interruptions		Disqual Fig	
Insertions		Other(note...)	

"@E" 22dh(8)3if.' " @H" ~+5b.,8..... (4,0) "@D" ~-',2frp(,44)8,5 " @I" 1m,32,48- (-22,25) "@L" ~-pb' "@J" 8,5dq,22 "@C" fh34. "@L" b`4... "@G" '3',4'rp(22)34,3 [0,19] "@L" /4b`4. "@F" /.'. 3ifta,3.' (4,0) "@A" ++,ifb,2f.' "@L"c..... "@B" -. '9,6m6f,if

Fig 1 E	K	Fig 2 H	K	Fig 3 D	K	Fig 4 I	K	Fig 5 L	K	Fig 6 J	K	Fig 7 C	K	Fig 8 L	K	Fig 9 G	K	Fig 10 L	K	Fig 11 F	K	Fig 12 A	K	Fig 13 L	K	Fig 14 B	K
5.3.1.1	18	8.4.2.1	14	8.6.3.2	13	7.2.1.1	6	8.4.2.2	17	7.4.5.1	15	5.2.1.1	17	8.4.1.1	13	8.6.1.1	11	8.4.1.1	13	6.2.1.1	15	8.4.1.1	13	8.5.5.1	10	7.2.4.2	6
9.2.2.4	11	9.1.1.5	14	9.9.6.2	17	9.1.3.4	8			9.8.2.1	5	9.9.1.4	15	9.1.5.1	2	9.1.1.3	10	9.1.1.1	6	9.10.6.3	19	9.10.6.4	19			9.1.3.8	12
9.8.1.1	7	9.8.5.1	3	9.4.3.4	11	9.2.3.6	12			9.1.2.5	11	9.4.5.3	8			9.1.1.1	9	9.1.5.1	2	9.1.5.3	6	9.9.5.2	11			9.1.3.6	10
9.10.5.3	13			9.8.3.1	3	9.8.3.2	7			9.2.4.4	9					9.2.3.4	6									9.9.3.6	14
				9.1.3.5	9											9.4.3.3	8									9.10.8.4	15
																9.1.3.3	6										
	49		31		53		33		6		40		40		6		50		6		40		43		6		57

Pilot: **PROPOSAL C**

A/C:

Team: **GER**

PROPOSAL D



CIVA	Unlimited	SEP 23
Programme2	EAC 23 PAVULLO, ITA	

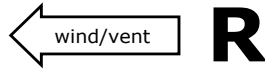

Figure K
460
Total K
500

Judges Name		Flight #
Signature	Number	

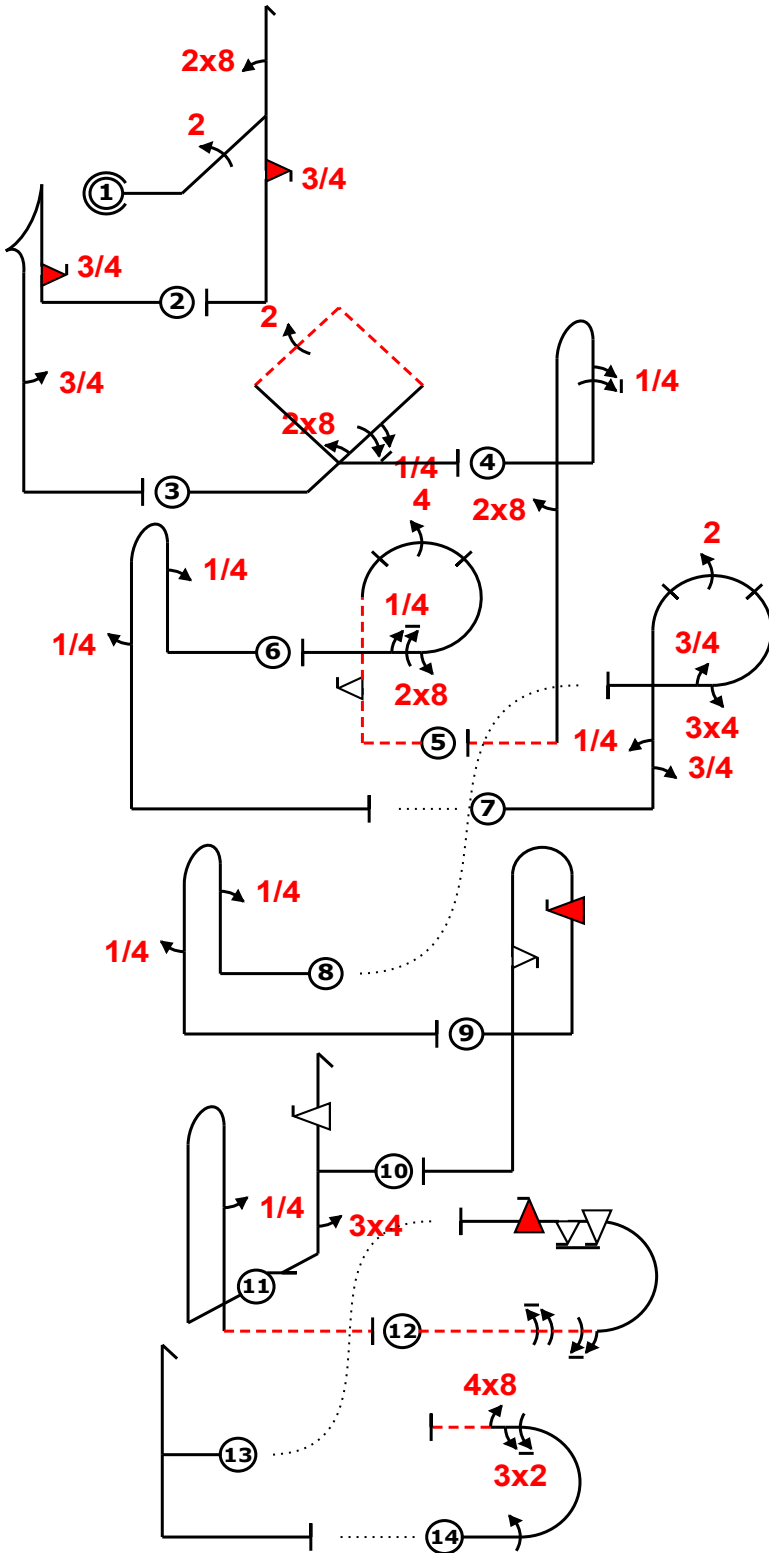

Fig	Grade	Pos	Remarks
1	.		
2	.		
3	.		
4	.		
5	.		
6	.		
7	.		
8	.		
9	.		
10	.		
11	.		
12	.		
13	.		
14	.		

Positioning
40

Too Low		Trg Violation	
Too High		Wing Rocks	
Interruptions		Disqual Fig	
Insertions		Other(note...)	

"@E" 22dh(8)3if..' "@F" ,3ifta3.. "@J" 8`),5dq,22 "@H" ,5b,'',8....' - "@D" -''2frp(44)8,5 "@L" ,4b, 4...'++~ (4,0) "@G" ++',3,4''rp(22)34,3 (-15,21) "@L" ,4b',4''++~ "@A" .ifb2f...' "@C" fh34 "@L " .''b4.'''~ "@B" -.'9,6m6f,if (-11,17) "@L" h++ (5,0) "@I" 1m32,48- eu eu eu eu eu eu eu

Fig 1 E	K	Fig 2 F	K	Fig 3 J	K	Fig 4 H	K	Fig 5 D	K	Fig 6 L	K	Fig 7 G	K	Fig 8 L	K	Fig 9 A	K	Fig 10 C	K	Fig 11 L	K	Fig 12 B	K	Fig 13 L	K	Fig 14 I	K
5.3.1.1	18	6.2.1.1	15	7.4.5.1	15	8.4.2.1	14	8.6.3.2	13	8.4.1.1	13	8.6.1.1	11	8.4.1.1	13	8.4.1.1	13	5.2.1.1	17	8.4.2.1	14	7.2.4.2	6	5.2.1.1	17	7.2.1.1	6
9.2.2.4	11	9.10.6.3	19	9.8.2.1	5	9.1.1.5	14	9.9.6.2	17	9.1.1.1	6	9.1.1.3	10	9.1.1.1	6	9.10.6.4	19	9.9.1.4	15	9.1.5.1	2	9.1.3.8	12			9.1.3.4	8
9.8.1.1	7	9.1.5.3	6	9.1.2.5	11	9.8.5.1	3	9.4.3.4	11	9.1.5.1	2	9.1.1.1	6	9.1.5.1	2	9.9.5.2	11	9.4.5.3	8			9.1.3.6	10			9.2.3.6	12
9.10.5.3	13			9.2.4.4	9			9.8.3.1	3			9.2.3.4	9									9.9.3.6	14			9.8.3.2	7
								9.1.3.5	9			9.4.3.3	8									9.10.8.4	15				
	49		40		40		31		53		6		50		6		43		40		6		57		6		33

Pilot: **PROPOSAL D**

A/C:

Team: **GER**

PROPOSAL D



CIVA Unlimited SEP 23
 Programme2 EAC 23 PAVULLO, ITA

Figure K
460
 Total K
500

Judges Name		Flight #
Signature	Number	

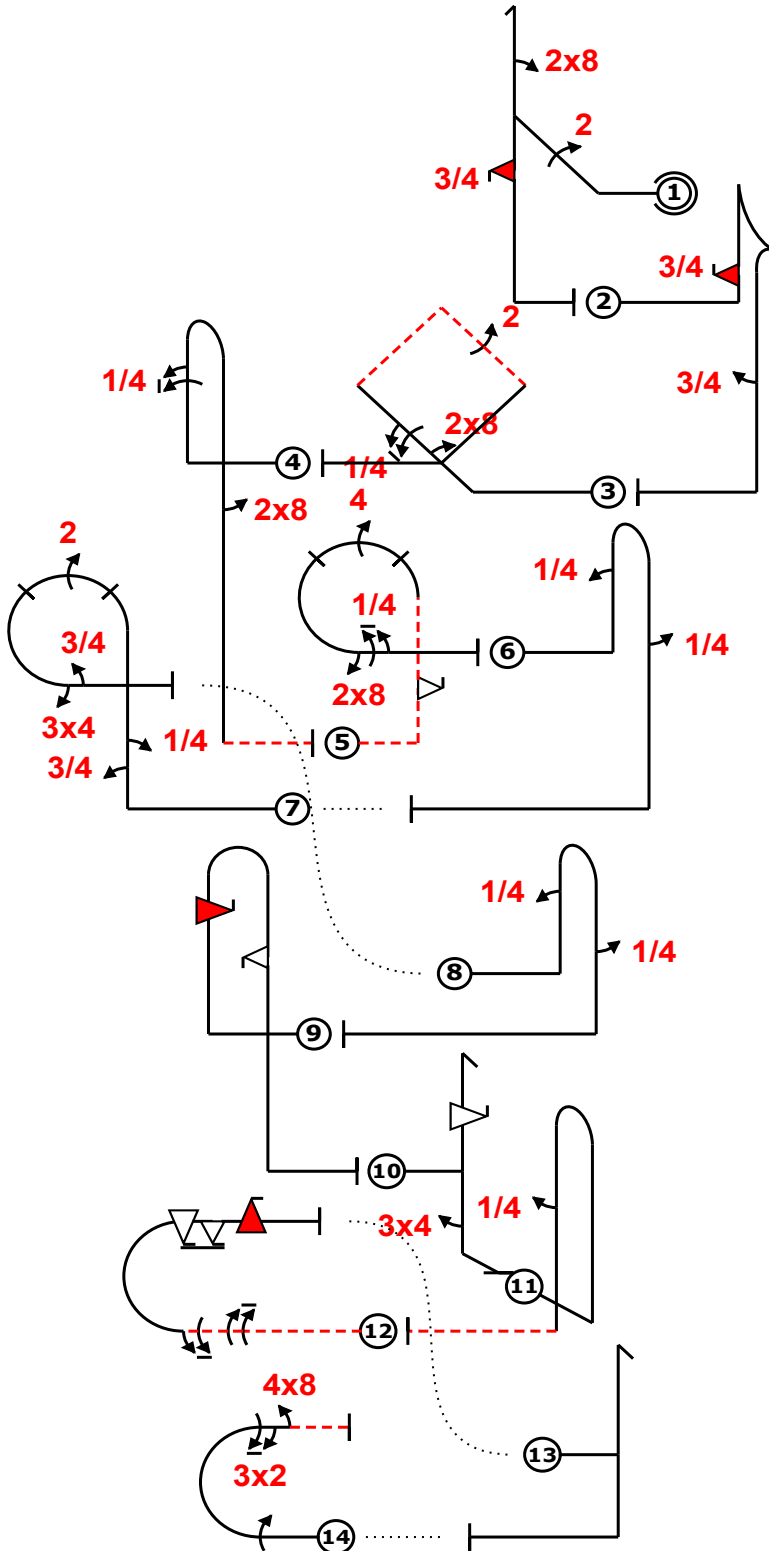
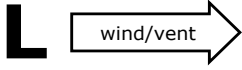

Fig	Grade	Pos	Remarks
1	.		
2	.		
3	.		
4	.		
5	.		
6	.		
7	.		
8	.		
9	.		
10	.		
11	.		
12	.		
13	.		
14	.		

Positioning **40**

Too Low		Trg Violation	
Too High		Wing Rocks	
Interruptions		Disqual Fig	
Insertions		Other(note...)	

"@E" 22dh(8)3if.. "eF" ,3ifta3.. "@J" 8`),5dq,22 "@H" ,5b,'"8...'- "@D" -'2frp(44)8,5 "@L" ,4b, 4...'+++~ (4,0) "@G" ++',3,4''rp(22)34,3 (-15,21) "@L" ,4b',4'++++~ "@A" .ifb2f...' "@C" fh34 "@L " .''b4.'---~ "@B" -.'9,6m6f,if (-11,17) "@L" h++ (5,0) "@I" 1m32,48- eu eu eu eu eu eu eu

Fig 1 E	K	Fig 2 F	K	Fig 3 J	K	Fig 4 H	K	Fig 5 D	K	Fig 6 L	K	Fig 7 G	K	Fig 8 L	K	Fig 9 A	K	Fig 10 C	K	Fig 11 L	K	Fig 12 B	K	Fig 13 L	K	Fig 14 I	K
5.3.1.1	18	6.2.1.1	15	7.4.5.1	15	8.4.2.1	14	8.6.3.2	13	8.4.1.1	13	8.6.1.1	11	8.4.1.1	13	8.4.1.1	13	5.2.1.1	17	8.4.2.1	14	7.2.4.2	6	5.2.1.1	17	7.2.1.1	6
9.2.2.4	11	9.10.6.3	19	9.8.2.1	5	9.1.1.5	14	9.9.6.2	17	9.1.1.1	6	9.1.1.3	10	9.1.1.1	6	9.10.6.4	19	9.9.1.4	15	9.1.5.1	2	9.1.3.8	12			9.1.3.4	8
9.8.1.1	7	9.1.5.3	6	9.1.2.5	11	9.8.5.1	3	9.4.3.4	11	9.1.5.1	2	9.1.1.1	6	9.1.5.1	2	9.9.5.2	11	9.4.5.3	8			9.1.3.6	10			9.2.3.6	12
9.10.5.3	13			9.2.4.4	9			9.8.3.1	3			9.2.3.4	9									9.9.3.6	14			9.8.3.2	7
								9.1.3.5	9			9.4.3.3	8									9.10.8.4	15				
	49		40		40		31		53		6		50		6		43		40		6		57		6		33

Pilot: **PROPOSAL D**

A/C:

Team: **GER**

PROPOSAL E



CIVA	Unlimited	SEP 23
Programme2	EAC 23 PAVULLO, ITA	

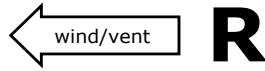

Figure K
460
Total K
500

Judges Name		Flight #
Signature	Number	

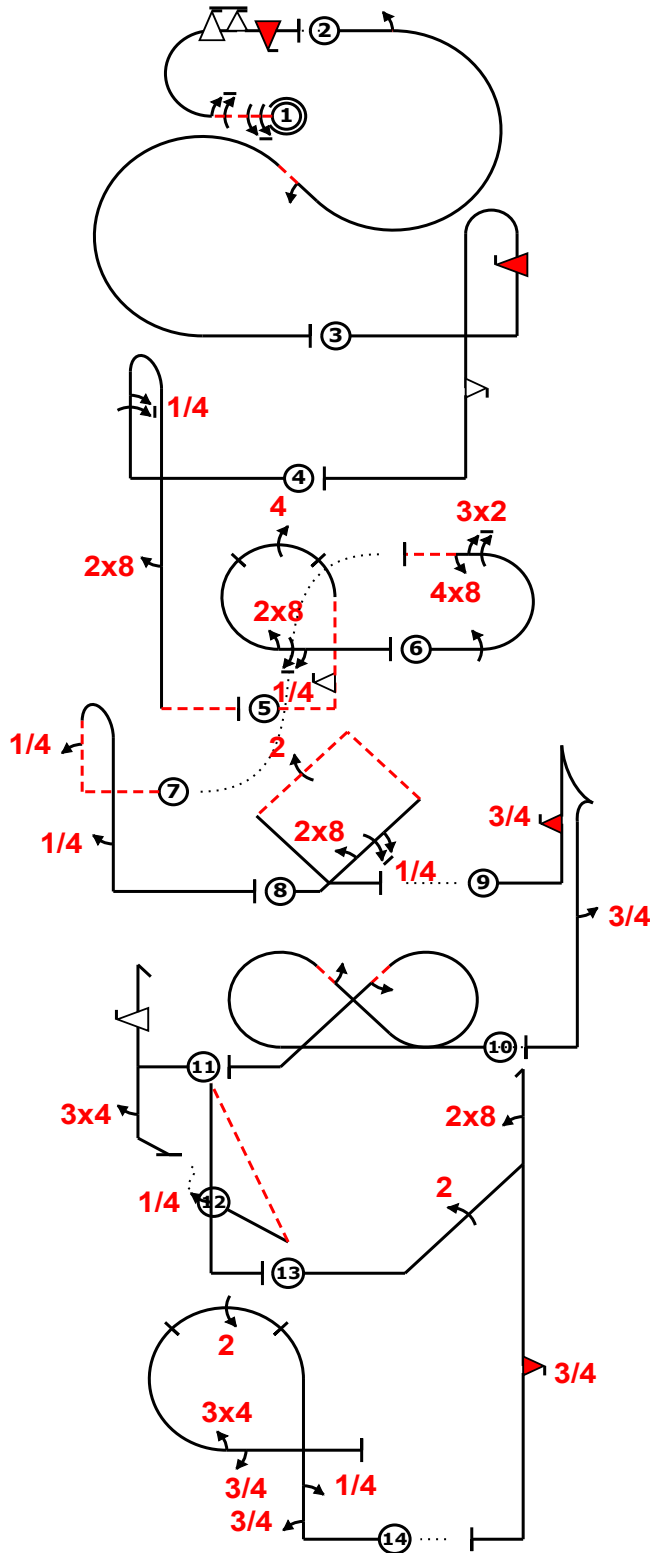

Fig	Grade	Pos	Remarks
1	.		
2	.		
3	.		
4	.		
5	.		
6	.		
7	.		
8	.		
9	.		
10	.		
11	.		
12	.		
13	.		
14	.		

Positioning
40

Too Low		Trg Violation	
Too High		Wing Rocks	
Interruptions		Disqual Fig	
Insertions		Other(note...)	

```
ed "@B" -1% /-~~~~9,6m6f,if+~ (-2,0) "@L" 11% ~~~~~2iac(~2~)+~~~~~ "@A" ~++ifb
..2f,+~ "OH" ++,5b...8... "eD" 1% -2frp(,44)8,5 "eI" 1m,32,48- (-14,20) "@L" -`4b.,4~ "eJ"
~~~~~+8,5dq',22'+~~~~ (4,0) "eF" ~~~~+.3iffta3...+~~~~ (2,0) "@L" cc(2)2+~~~~ "eC" fh,34 (0,2) "@L"
..zt...4' "eE" ~+.22'dh(8)...'3if.... (-2,0) "eG" 5% '3',4rp(22)34,3 eu eu eu eu eu eu eu eu
```

Fig 1 B	K	Fig 2 L	K	Fig 3 A	K	Fig 4 H	K	Fig 5 D	K	Fig 6 I	K	Fig 7 L	K	Fig 8 J	K	Fig 9 F	K	Fig 10 L	K	Fig 11 C	K	Fig 12 L	K	Fig 13 E	K	Fig 14 G	K
7.2.4.2	6	7.5.5.3	15	8.4.1.1	13	8.4.2.1	14	8.6.3.2	13	7.2.1.1	6	8.4.4.2	14	7.4.5.1	15	6.2.1.1	15	7.8.4.1	19	5.2.1.1	17	1.2.9.1	15	5.3.1.1	18	8.6.1.1	11
9.1.3.8	12	9.1.3.2	4	9.10.6.4	19	9.1.1.5	14	9.9.6.2	17	9.1.3.4	8	9.1.1.1	6	9.8.2.1	5	9.10.6.3	19	9.1.4.2	4	9.9.1.4	15	9.1.5.1	2	9.2.2.4	11	9.1.1.3	10
9.1.3.6	10	9.1.2.2	6	9.9.5.2	11	9.8.5.1	3	9.4.3.4	11	9.2.3.6	12	9.1.5.1	2	9.1.2.5	11	9.1.5.3	6	9.1.4.2	4	9.4.5.3	8			9.8.1.1	7	9.1.1.1	6
9.9.3.6	14							9.8.3.1	3	9.8.3.2	7			9.2.4.4	9									9.10.5.3	13	9.2.3.4	9
9.10.8.4	15							9.1.3.5	9																	9.4.3.3	8
	57		6		43		31		53		33		6		40		40		6		40		6		49		50

Pilot: **PROPOSAL E**

A/C:

Team: **GRE**

PROPOSAL E



CIVA Unlimited SEP 23
 Programme2 EAC 23 PAVULLO, ITA

Figure K
460
 Total K
500

Judges Name		Flight #
Signature	Number	

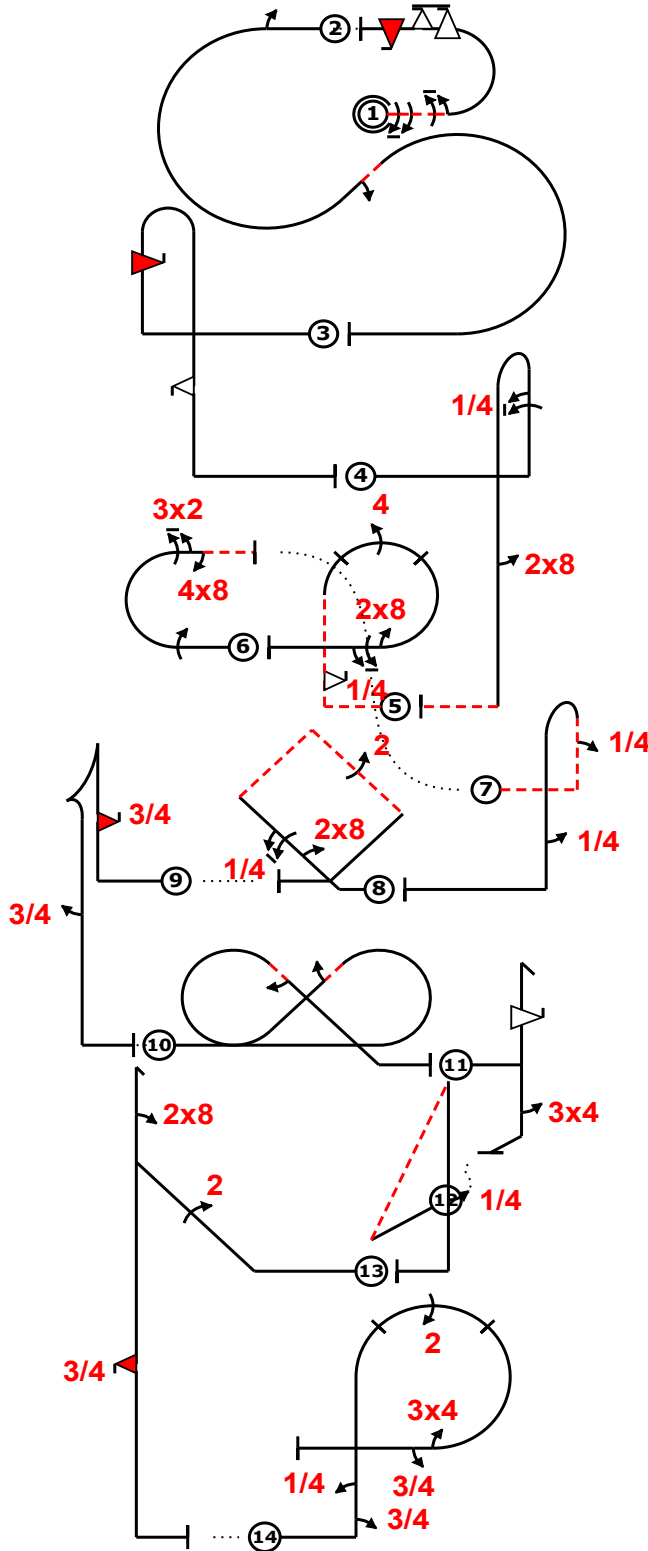
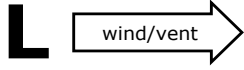

Fig	Grade	Pos	Remarks
1	.		
2	.		
3	.		
4	.		
5	.		
6	.		
7	.		
8	.		
9	.		
10	.		
11	.		
12	.		
13	.		
14	.		

Positioning
40 .

Too Low		Trg Violation	
Too High		Wing Rocks	
Interruptions		Disqual Fig	
Insertions		Other(note...)	

```
ed "@B" -1% /-~~~~9,6m6f,if+~ (-2,0) "@L" 11% ~~~~~2iac(``2`~)~ "@A" ~++ifb
..2f,+~ "OH" ++,5b...8... "eD" 1% -2frp(,44)8,5 "eI" 1m,32,48- (-14,20) "@L" -`4b.,4+~ "eJ"
~~~~~+8,5dq',22'+~~~~ (4,0) "eF" ~~~+.3iffta3...+~~~~ (2,0) "@L" cc(2)2+~~~~ "eC" fh,34 (0,2) "@L"
..zt...4' "eE" ~+.22'dh(8)... '3if.... (-2,0) "eG" 5% '3',4rp(22)34,3 eu eu eu eu eu eu eu eu
```

Fig 1 B	K	Fig 2 L	K	Fig 3 A	K	Fig 4 H	K	Fig 5 D	K	Fig 6 I	K	Fig 7 L	K	Fig 8 J	K	Fig 9 F	K	Fig 10 L	K	Fig 11 C	K	Fig 12 L	K	Fig 13 E	K	Fig 14 G	K
7.2.4.2	6	7.5.5.3	15	8.4.1.1	13	8.4.2.1	14	8.6.3.2	13	7.2.1.1	6	8.4.4.2	14	7.4.5.1	15	6.2.1.1	15	7.8.4.1	19	5.2.1.1	17	1.2.9.1	15	5.3.1.1	18	8.6.1.1	11
9.1.3.8	12	9.1.3.2	4	9.10.6.4	19	9.1.1.5	14	9.9.6.2	17	9.1.3.4	8	9.1.1.1	6	9.8.2.1	5	9.10.6.3	19	9.1.4.2	4	9.9.1.4	15	9.1.5.1	2	9.2.2.4	11	9.1.1.3	10
9.1.3.6	10	9.1.2.2	6	9.9.5.2	11	9.8.5.1	3	9.4.3.4	11	9.2.3.6	12	9.1.5.1	2	9.1.2.5	11	9.1.5.3	6	9.1.4.2	4	9.4.5.3	8			9.8.1.1	7	9.1.1.1	6
9.9.3.6	14							9.8.3.1	3	9.8.3.2	7			9.2.4.4	9									9.10.5.3	13	9.2.3.4	9
9.10.8.4	15							9.1.3.5	9																	9.4.3.3	8
	57		6		43		31		53		33		6		40		40		6		40		6		49		50

Pilot: **PROPOSAL E**

A/C:

Team: **GRE**

PROPOSAL F



CIVA	Unlimited	SEP 23
Programme2	EAC 23 PAVULLO, ITA	

Figure K
460
Total K
500

Judges Name		Flight #
Signature	Number	

← wind/vent **R**

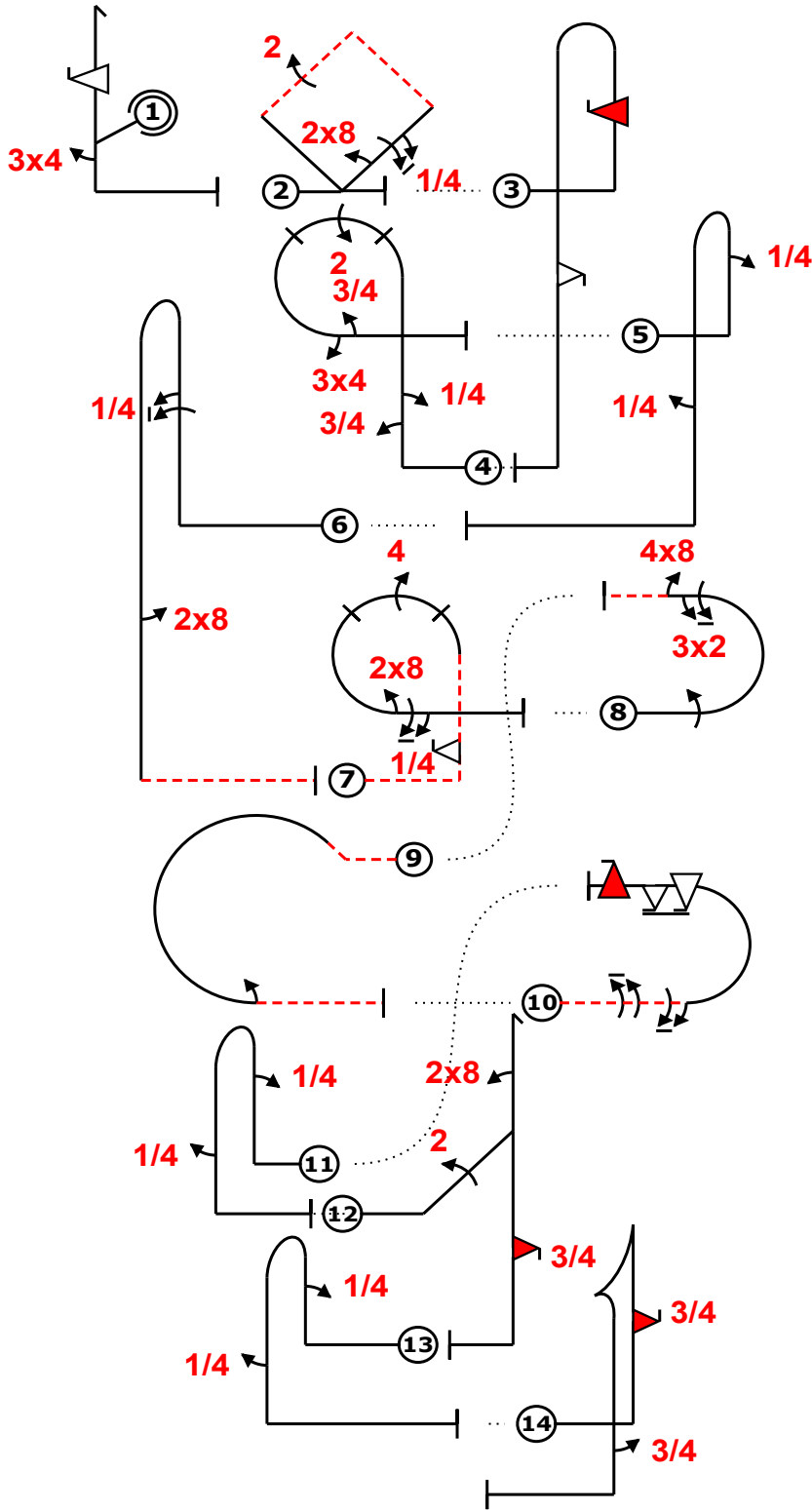

Fig	Grade	Pos	Remarks
1	.		
2	.		
3	.		
4	.		
5	.		
6	.		
7	.		
8	.		
9	.		
10	.		
11	.		
12	.		
13	.		
14	.		

Positioning
40 .

Too Low		Trg Violation	
Too High		Wing Rocks	
Interruptions		Disqual Fig	
Insertions		Other(note...)	

ej "@C" 1% fh...34+ "@J" 2> -1% ...+8,5'dq',22+ ... (4,0) "@A" -1% if'b...'2f...'+' (2,0) "@G" '3,4''rp(22),34,3~ (7,0) "@L" -1% '+,4b.,4.'+'++~ (-4,0) "@H" +'5.b...'8...'@D' ~-2fr p(,44)8,5 (2,0) "@I" 1m32,48- (-8,18) "@L" 6% ...rc2- ... (6,0) "@B" -9,6m6f,if+ ... (-13,19) "@L" ...+4b,4 (-2,0) "@E" 22dh(8).'3if.' "@L" ...4b,4++ (1,0) "@F" ...+'.',3if'ta'3' e

Fig 1 C	K	Fig 2 J	K	Fig 3 A	K	Fig 4 G	K	Fig 5 L	K	Fig 6 H	K	Fig 7 D	K	Fig 8 I	K	Fig 9 L	K	Fig 10 B	K	Fig 11 L	K	Fig 12 E	K	Fig 13 L	K	Fig 14 F	K
5.2.1.1	17	7.4.5.1	15	8.4.1.1	13	8.6.1.1	11	8.4.1.1	13	8.4.2.1	14	8.6.3.2	13	7.2.1.1	6	8.5.3.2	11	7.2.4.2	6	8.4.1.1	13	5.3.1.1	18	8.4.1.1	13	6.2.1.1	15
9.9.1.4	15	9.8.2.1	5	9.10.6.4	19	9.1.1.3	10	9.1.1.1	6	9.1.1.5	14	9.9.6.2	17	9.1.3.4	8	9.1.3.2	4	9.1.3.8	12	9.1.1.1	6	9.2.2.4	11	9.1.1.1	6	9.10.6.3	19
9.4.5.3	8	9.1.2.5	11	9.9.5.2	11	9.1.1.1	6	9.1.5.1	2	9.8.5.1	3	9.4.3.4	11	9.2.3.6	12			9.1.3.6	10	9.1.5.1	2	9.8.1.1	7	9.1.5.1	2	9.1.5.3	6
		9.2.4.4	9			9.2.3.4	9					9.1.3.5	9	9.8.3.1	3	9.8.3.2	7	9.9.3.6	14			9.10.5.3	13				
						9.4.3.3	8											9.10.8.4	15								
	40		40		43		50		6		31		53		33		6		57		6		49		6		40

Pilot: PROPOSAL F

A/C:

Team: HUN

PROPOSAL F



CIVA Unlimited SEP 23
 Programme2 EAC 23 PAVULLO, ITA

Figure K
460
 Total K
500

Judges Name		Flight #
Signature	Number	

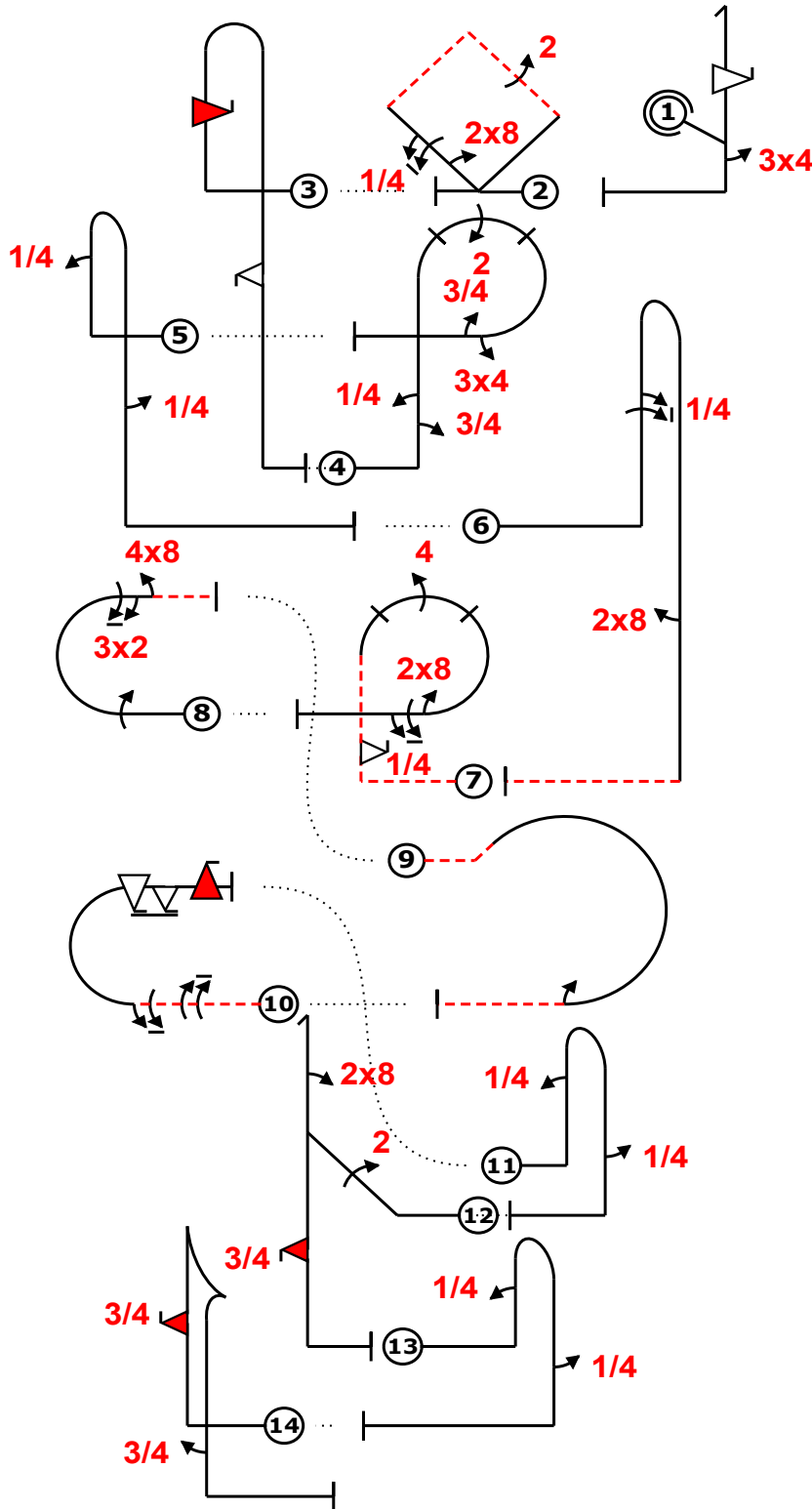
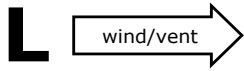

Fig	Grade	Pos	Remarks
1	.		
2	.		
3	.		
4	.		
5	.		
6	.		
7	.		
8	.		
9	.		
10	.		
11	.		
12	.		
13	.		
14	.		

Positioning **40** .

Too Low		Trg Violation	
Too High		Wing Rocks	
Interruptions		Disqual Fig	
Insertions		Other(note...)	

ej "@C" 1% fh...34+ "@J" 2> -1% ...+8,5'dq',22+ ... (4,0) "@A" -1% if'b...'2f...'+' (2,0) "@G" '3,4''rp(22),34,3~ (7,0) "@L" -1% '+,4b..,4.''+... (-4,0) "@H" +'5.b...'8..'~ "@D" ~-2fr p(,44)8,5 (2,0) "@I" 1m32,48- (-8,18) "@L" 6% ...rc2-... (6,0) "@B" -9,6m6f,if+ ... (-13,19) "@L" ...+4b,4 (-2,0) "@E" 22dh(8).'3if.' "@L" ...4b,4++ (1,0) "@F" ...+'3ifta'3'e

Fig 1 C	K	Fig 2 J	K	Fig 3 A	K	Fig 4 G	K	Fig 5 L	K	Fig 6 H	K	Fig 7 D	K	Fig 8 I	K	Fig 9 L	K	Fig 10 B	K	Fig 11 L	K	Fig 12 E	K	Fig 13 L	K	Fig 14 F	K
5.2.1.1	17	7.4.5.1	15	8.4.1.1	13	8.6.1.1	11	8.4.1.1	13	8.4.2.1	14	8.6.3.2	13	7.2.1.1	6	8.5.3.2	11	7.2.4.2	6	8.4.1.1	13	5.3.1.1	18	8.4.1.1	13	6.2.1.1	15
9.9.1.4	15	9.8.2.1	5	9.10.6.4	19	9.1.1.3	10	9.1.1.1	6	9.1.1.5	14	9.9.6.2	17	9.1.3.4	8	9.1.3.2	4	9.1.3.8	12	9.1.1.1	6	9.2.2.4	11	9.1.1.1	6	9.10.6.3	19
9.4.5.3	8	9.1.2.5	11	9.9.5.2	11	9.1.1.1	6	9.1.5.1	2	9.8.5.1	3	9.4.3.4	11	9.2.3.6	12			9.1.3.6	10	9.1.5.1	2	9.8.1.1	7	9.1.5.1	2	9.1.5.3	6
		9.2.4.4	9			9.2.3.4	9					9.1.3.5	9	9.8.3.1	3	9.8.3.2	7	9.9.3.6	14			9.10.5.3	13				
						9.4.3.3	8												9.10.8.4	15							
						9.1.3.3	6																				

PROPOSAL G



CIVA	Unlimited	SEP 23
Programme2	EAC 23 PAVULLO, ITA	

Figure K
460
Total K
500

Judges Name		Flight #
Signature	Number	

← wind/vent **R**

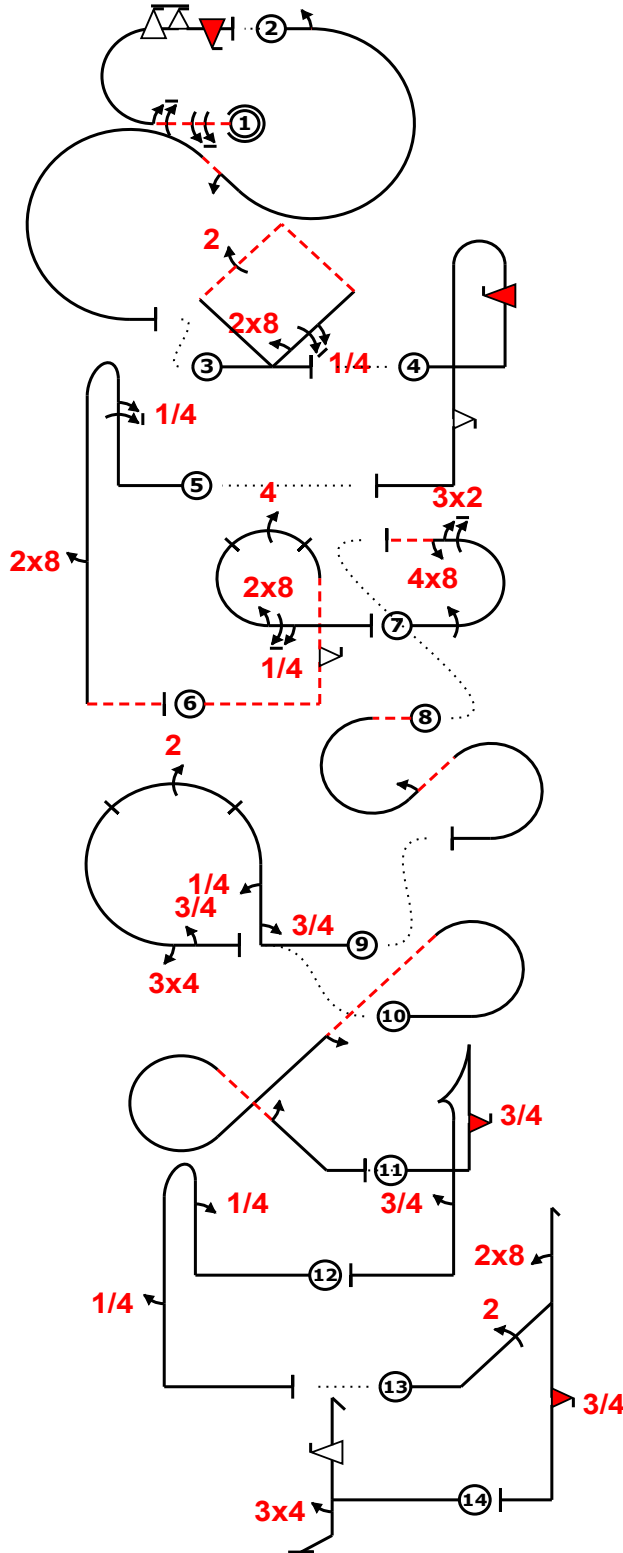

Fig	Grade	Pos	Remarks
1	.		
2	.		
3	.		
4	.		
5	.		
6	.		
7	.		
8	.		
9	.		
10	.		
11	.		
12	.		
13	.		
14	.		

Positioning **40** .

Too Low		Trg Violation	
Too High		Wing Rocks	
Interruptions		Disqual Fig	
Insertions		Other(note...)	

```
ed "@B" ~`9,6m6f,if+` (-1,0) "@L" 10% ~~~~~ 2iac("2") + ~~~~~ (0,4) "@J" ~~~~~
+`8,5dq',22+` (4,0) "@A" ifb..'2f' (-10,0) "@H" +,5b..'8..' "@D" ~~~~~,2frp,(44)8,5 "@
I" -1% 1m,32,48- (7,15) "@L" ~~~~~ iac("2")+ ~~~~~ (-3,9) "@G" 7% ~~~~~,3`
4`~~~~ rp,(22),34,3+` (8,6) "@L" ~~~~~ cc(...'2..)'2` +` (-2,0) "@F" ~~~~~ +',3ifta',3
```

Fig 1 B	K	Fig 2 L	K	Fig 3 J	K	Fig 4 A	K	Fig 5 H	K	Fig 6 D	K	Fig 7 I	K	Fig 8 L	K	Fig 9 G	K	Fig 10 L	K	Fig 11 F	K	Fig 12 L	K	Fig 13 E	K	Fig 14 C	K
7.2.4.2	6	7.5.5.3	15	7.4.5.1	15	8.4.1.1	13	8.4.2.1	14	8.6.3.2	13	7.2.1.1	6	7.5.2.4	15	8.6.1.1	11	7.8.4.1	19	6.2.1.1	15	8.4.1.1	13	5.3.1.1	18	5.2.1.1	17
9.1.3.8	12	9.1.3.2	4	9.8.2.1	5	9.10.6.4	19	9.1.1.5	14	9.9.6.2	17	9.1.3.4	8	9.1.2.2	6	9.1.1.3	10	9.1.4.2	4	9.10.6.3	19	9.1.1.1	6	9.2.2.4	11	9.9.1.4	15
9.1.3.6	10	9.1.2.2	6	9.1.2.5	11	9.9.5.2	11	9.8.5.1	3	9.4.3.4	11	9.2.3.6	12			9.1.1.1	6	9.1.4.2	4	9.1.5.3	6	9.1.5.1	2	9.8.1.1	7	9.4.5.3	8
9.9.3.6	14			9.2.4.4	9					9.8.3.1	3	9.8.3.2	7			9.2.3.4	9							9.10.5.3	13		
9.10.8.4	15									9.1.3.5	9					9.4.3.3	8										
	57		6		40		43		31		53		33		6		50		6		40		6		49		40

Pilot: **PROPOSAL G**

A/C:

Team: **HUN**

PROPOSAL G



CIVA Unlimited SEP 23
 Programme2 EAC 23 PAVULLO, ITA

Figure K
460
 Total K
500

Judges Name		Flight #
Signature	Number	

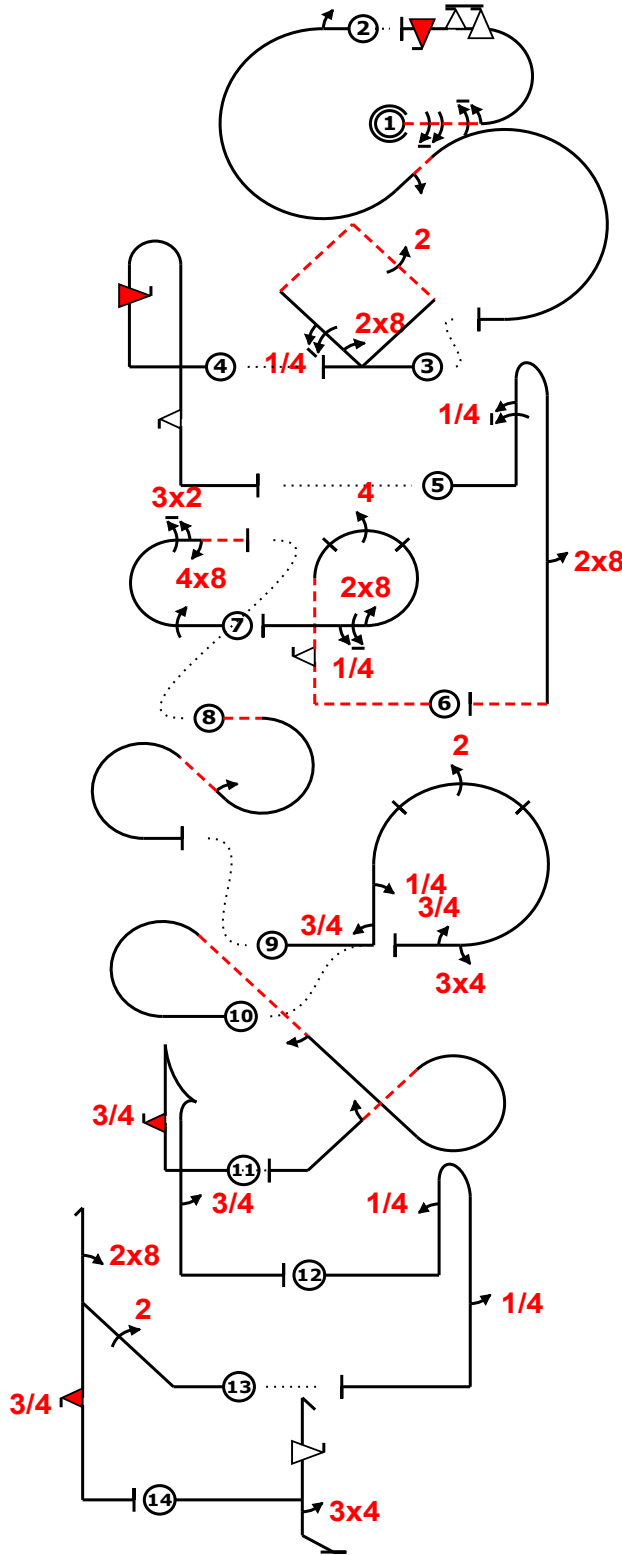
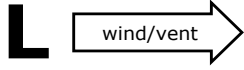

Fig	Grade	Pos	Remarks
1	.		
2	.		
3	.		
4	.		
5	.		
6	.		
7	.		
8	.		
9	.		
10	.		
11	.		
12	.		
13	.		
14	.		

Positioning **40**

Too Low		Trg Violation	
Too High		Wing Rocks	
Interruptions		Disqual Fig	
Insertions		Other(note...)	

```
ed "@B" ~`9,6m6f,if+` (-1,0) "@L" 10% ~~~~~ 2iac(`2`)+ ~~~~~ (0,4) "@J" ~`+` ~`8,5dq',22+` (4,0) "@A" ifb..'2f' (-10,0) "@H" ~`+,5b..'8..' "@D" ~`---',2frp,(44)8,5 "@I" ~`-1% 1m,32,48- (7,15) "@L" ~`~~~~ iac(`2`)+ ~~~~~ (-3,9) "@G" 7% ~`3` ~`4` ~`rp,(22),34,3+` (8,6) "@L" ~`~~~~ cc(...'2..)'2`+` ~~~~~ (-2,0) "@F" ~`+`',3ifta`,3
```

Fig 1 B	K	Fig 2 L	K	Fig 3 J	K	Fig 4 A	K	Fig 5 H	K	Fig 6 D	K	Fig 7 I	K	Fig 8 L	K	Fig 9 G	K	Fig 10 L	K	Fig 11 F	K	Fig 12 L	K	Fig 13 E	K	Fig 14 C	K
7.2.4.2	6	7.5.5.3	15	7.4.5.1	15	8.4.1.1	13	8.4.2.1	14	8.6.3.2	13	7.2.1.1	6	7.5.2.4	15	8.6.1.1	11	7.8.4.1	19	6.2.1.1	15	8.4.1.1	13	5.3.1.1	18	5.2.1.1	17
9.1.3.8	12	9.1.3.2	4	9.8.2.1	5	9.10.6.4	19	9.1.1.5	14	9.9.6.2	17	9.1.3.4	8	9.1.2.2	6	9.1.1.3	10	9.1.4.2	4	9.10.6.3	19	9.1.1.1	6	9.2.2.4	11	9.9.1.4	15
9.1.3.6	10	9.1.2.2	6	9.1.2.5	11	9.9.5.2	11	9.8.5.1	3	9.4.3.4	11	9.2.3.6	12			9.1.1.1	6	9.1.4.2	4	9.1.5.3	6	9.1.5.1	2	9.8.1.1	7	9.4.5.3	8
9.9.3.6	14			9.2.4.4	9					9.8.3.1	3	9.8.3.2	7			9.2.3.4	9							9.10.5.3	13		
9.10.8.4	15									9.1.3.5	9					9.4.3.3	8										
	57		6		40		43		31		53		33		6		50		6		40		6		49		40

Pilot: **PROPOSAL G**

A/C:

Team: **HUN**

PROPOSAL H



CIVA	Unlimited	SEP 23
Programme2	EAC 23 PAVULLO, ITA	

Figure K
460
Total K
500

Judges Name		Flight #
Signature	Number	

← wind/vent **R**

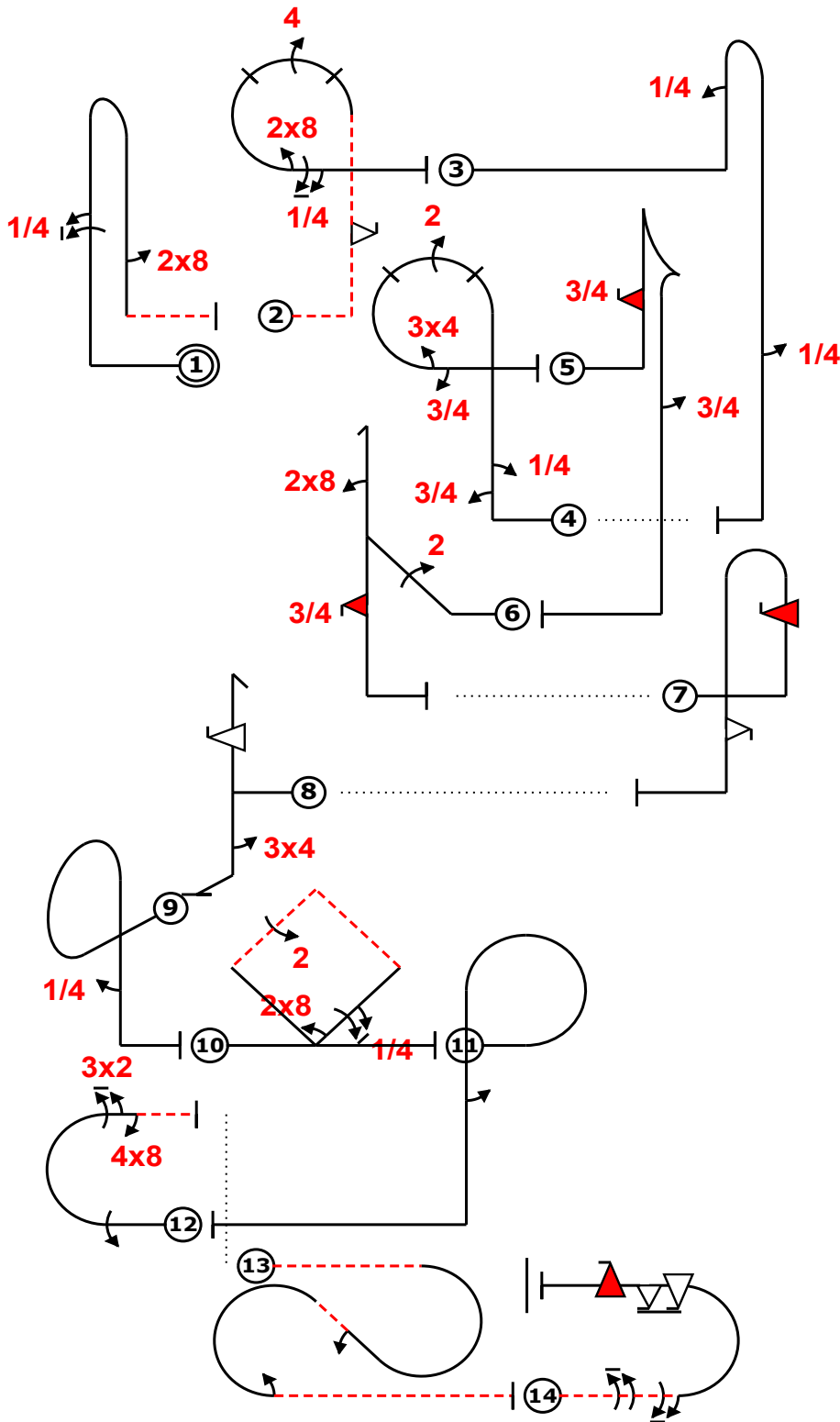

Fig	Grade	Pos	Remarks
1	.		
2	.		
3	.		
4	.		
5	.		
6	.		
7	.		
8	.		
9	.		
10	.		
11	.		
12	.		
13	.		
14	.		

Positioning **40**

Too Low	<input type="checkbox"/>	Trg Violation	<input type="checkbox"/>
Too High	<input type="checkbox"/>	Wing Rocks	<input type="checkbox"/>
Interruptions	<input type="checkbox"/>	Disqual Fig	<input type="checkbox"/>
Insertions	<input type="checkbox"/>	Other(note...)	<input type="checkbox"/>

ed "@H" /. '5.' 'b.8- 2> "@D" - .',2f'rp(,44)8,5~ "@L" ~~~++4b....'4....'++ (-6,0) "@G" 3,4.'rp(,2 2)34,3 "@F" ~~~~+.3iffta3....' "@E" ~~~+.22dh(8)',3if.' (13,0) "@A" ifb.'2f [-18,0] "@C" /fh34 "@L" p ,4' " @J" ~~~+8',5dq22 "@L" ~~~~p2..'+~+~ "@I" 1m32,48- [0,11] "@L" ~~~~iac(2)2- "@B" -9,6m6 f,if

Fig 1 H	K	Fig 2 D	K	Fig 3 L	K	Fig 4 G	K	Fig 5 F	K	Fig 6 E	K	Fig 7 A	K	Fig 8 C	K	Fig 9 L	K	Fig 10 J	K	Fig 11 L	K	Fig 12 I	K	Fig 13 L	K	Fig 14 B	K
8.4.2.1	14	8.6.3.2	13	8.4.1.1	13	8.6.1.1	11	6.2.1.1	15	5.3.1.1	18	8.4.1.1	13	5.2.1.1	17	8.6.5.1	11	7.4.5.1	15	8.6.5.1	11	7.2.1.1	6	7.5.7.4	15	7.2.4.2	6
9.1.1.5	14	9.9.6.2	17	9.1.1.1	6	9.1.1.3	10	9.10.6.3	19	9.2.2.4	11	9.10.6.4	19	9.9.1.4	15	9.1.5.1	2	9.8.2.1	5	9.1.5.2	4	9.1.3.4	8	9.1.2.2	6	9.1.3.8	12
9.8.5.1	3	9.4.3.4	11	9.1.5.1	2	9.1.1.1	6	9.1.5.3	6	9.8.1.1	7	9.9.5.2	11	9.4.5.3	8			9.1.2.5	11			9.2.3.6	12	9.1.3.2	4	9.1.3.6	10
		9.8.3.1	3			9.2.3.4	9			9.10.5.3	13							9.2.4.4	9			9.8.3.2	7			9.9.3.6	14
		9.1.3.5	9			9.4.3.3	8																			9.10.8.4	15
						9.1.3.3	6																				
	31		53		6		50		40		49		43		40		6		40		6		33		6		57

Pilot: **PROPOSAL H**

A/C:

Team: **LUX**

PROPOSAL H



CIVA Unlimited SEP 23
 Programme2 EAC 23 PAVULLO, ITA

Figure K
460
 Total K
500

Judges Name		Flight #
Signature	Number	

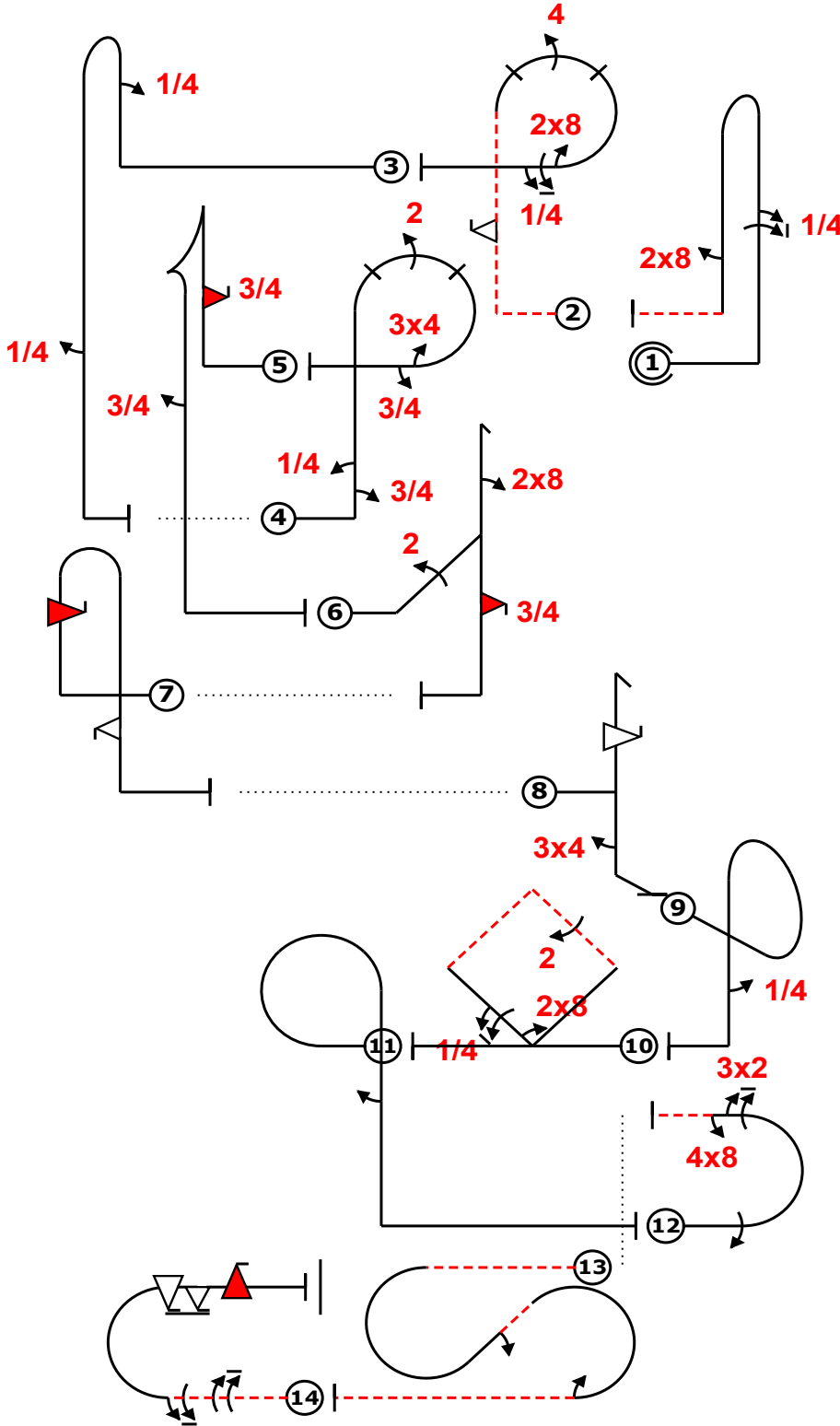
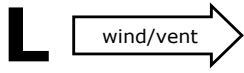

Fig	Grade	Pos	Remarks
1	.		
2	.		
3	.		
4	.		
5	.		
6	.		
7	.		
8	.		
9	.		
10	.		
11	.		
12	.		
13	.		
14	.		

Positioning **40** .

Too Low		Trg Violation	
Too High		Wing Rocks	
Interruptions		Disqual Fig	
Insertions		Other(note...)	

ed "@H" /.'5.'b.8- 2> "@D" -.',2f''rp(,44)8,5~ "@L" ~~~++4b....'4....'++ (-6,0) "@G" 3,4.'rp(,2
 2)34,3 "@F" ~~~~+.3iffta3....' "@E" ~+,22dh(8)',3if.' (13,0) "@A" ifb.'2f [-18,0] "@C" /fh34 "@L" p
 ,4' " "@J" ~~~+8',5dq22 "@L" ~~~~p2..'+~+~ "@I" 1m32,48- [0,11] "@L" ~~~~iac(2)2- "@B" -9,6m6
 f,if

Fig 1 H	K	Fig 2 D	K	Fig 3 L	K	Fig 4 G	K	Fig 5 F	K	Fig 6 E	K	Fig 7 A	K	Fig 8 C	K	Fig 9 L	K	Fig 10 J	K	Fig 11 L	K	Fig 12 I	K	Fig 13 L	K	Fig 14 B	K
8.4.2.1	14	8.6.3.2	13	8.4.1.1	13	8.6.1.1	11	6.2.1.1	15	5.3.1.1	18	8.4.1.1	13	5.2.1.1	17	8.6.5.1	11	7.4.5.1	15	8.6.5.1	11	7.2.1.1	6	7.5.7.4	15	7.2.4.2	6
9.1.1.5	14	9.9.6.2	17	9.1.1.1	6	9.1.1.3	10	9.10.6.3	19	9.2.2.4	11	9.10.6.4	19	9.9.1.4	15	9.1.5.1	2	9.8.2.1	5	9.1.5.2	4	9.1.3.4	8	9.1.2.2	6	9.1.3.8	12
9.8.5.1	3	9.4.3.4	11	9.1.5.1	2	9.1.1.1	6	9.1.5.3	6	9.8.1.1	7	9.9.5.2	11	9.4.5.3	8			9.1.2.5	11			9.2.3.6	12	9.1.3.2	4	9.1.3.6	10
		9.8.3.1	3			9.2.3.4	9			9.10.5.3	13							9.2.4.4	9			9.8.3.2	7			9.9.3.6	14
		9.1.3.5	9			9.4.3.3	8																			9.10.8.4	15
						9.1.3.3	6																				
	31		53		6		50		40		49		43		40		6		40		6		33		6		57

Pilot: PROPOSAL H

A/C:

Team: LUX

