

PROPOSAL A



CIVA Unlimited SEP 23
 Programme4 EAC 23 PAVULLO, ITA

Figure K
441
 Total K
481

| | | |
|-------------|--------|----------|
| Judges Name | | Flight # |
| Signature | Number | |

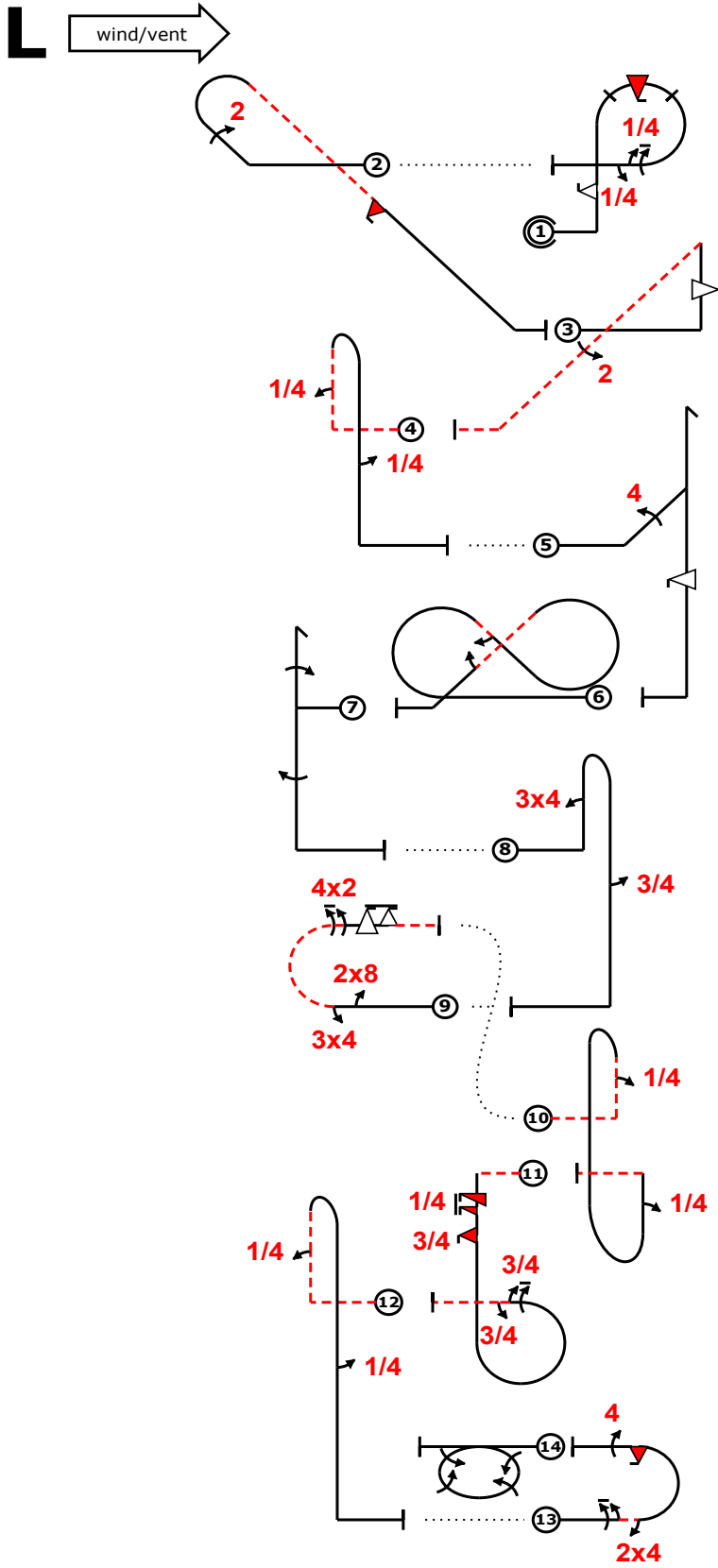

| Fig | Grade | Pos | Remarks |
|-----|-------|-----|---------|
| 1 | . | | |
| 2 | . | | |
| 3 | . | | |
| 4 | . | | |
| 5 | . | | |
| 6 | . | | |
| 7 | . | | |
| 8 | . | | |
| 9 | . | | |
| 10 | . | | |
| 11 | . | | |
| 12 | . | | |
| 13 | . | | |
| 14 | . | | |

Positioning
40

| | | | |
|---------------|--|----------------|--|
| Too Low | | Trg Violation | |
| Too High | | Wing Rocks | |
| Interruptions | | Disqual Fig | |
| Insertions | | Other(note...) | |

ed "@A" '2frp(if)5,4 (12,0) "@G" -3% +22db,....2if.....' "@F" ~+~fk.,22.- (0,0) "@L" ~,4
 'b.',4.~ (-5,0) "@B" ~,44dh.'f... (0,0) "@L" 1% ~cc(2)..'2~' (0,0) "@H" 1h.1.'+~
 (-7,0) "@J" ~,34'b.,3..'+ (2,0) "@C" .8,34m,42;6f- (-5,19) "@L" ~>4'bB(())'4'- (0,0) "@E" -5is;3
 if.'irp7,3- (0,0) "@L" ~,4'b..',4...'' (-9,0) "@D" -1% ',6,24m,2if,44 "@I" -1% 4j4 eu eu eu e

| Fig 1 A | K | Fig 2 G | K | Fig 3 F | K | Fig 4 L | K | Fig 5 B | K | Fig 6 L | K | Fig 7 H | K | Fig 8 J | K | Fig 9 C | K | Fig 10 L | K | Fig 11 E | K | Fig 12 L | K | Fig 13 D | K | Fig 14 I | K |
|----------|-----------|----------|-----------|---------|-----------|---------|----------|---------|-----------|---------|----------|---------|-----------|---------|-----------|---------|-----------|----------|----------|----------|-----------|----------|----------|----------|-----------|----------|-----------|
| 8.6.1.1 | 11 | 8.4.14.1 | 12 | 1.2.5.1 | 14 | 8.4.4.2 | 14 | 5.3.1.1 | 18 | 7.8.4.1 | 19 | 5.2.1.1 | 17 | 8.4.1.1 | 13 | 7.2.4.1 | 8 | 8.8.8.2 | 20 | 8.6.1.4 | 12 | 8.4.4.2 | 14 | 7.2.2.1 | 6 | 2.4.7.1 | 38 |
| 9.9.1.2 | 15 | 9.2.2.4 | 11 | 9.9.1.4 | 15 | 9.1.1.1 | 6 | 9.4.2.4 | 13 | 9.1.4.2 | 4 | 9.1.1.4 | 12 | 9.4.1.3 | 12 | 9.8.3.1 | 3 | 9.1.1.1 | 6 | 9.12.1.5 | 6 | 9.1.1.1 | 6 | 9.1.3.6 | 10 | | |
| 9.10.8.4 | 15 | 9.10.4.2 | 13 | 9.2.4.4 | 9 | 9.1.5.1 | 2 | 9.9.5.4 | 11 | 9.1.4.2 | 4 | 9.1.5.4 | 8 | 9.1.5.3 | 6 | 9.4.3.3 | 8 | 9.1.1.1 | 6 | 9.10.5.3 | 13 | 9.1.5.1 | 2 | 9.4.3.2 | 5 | | |
| 9.1.3.5 | 9 | | | | | | | | | | | | | | | 9.2.3.8 | 15 | | | 9.1.3.7 | 11 | | | 9.10.8.2 | 15 | | |
| 9.1.3.1 | 2 | | | | | | | | | | | | | | | 9.9.3.6 | 14 | | | 9.1.3.3 | 6 | | | 9.4.3.4 | 11 | | |
| | 52 | | 36 | | 38 | | 6 | | 42 | | 6 | | 37 | | 31 | | 48 | | 6 | | 48 | | 6 | | 47 | | 38 |

Pilot: **PROPOSAL A**

A/C:

Team: **FRA**

PROPOSAL B



| | | |
|------------|---------------------|--------|
| CIVA | Unlimited | SEP 23 |
| Programme4 | EAC 23 PAVULLO, ITA | |

← wind/vent **R**

Figure K
441
Total K
481

| | |
|-------------|--------|
| Judges Name | |
| Signature | Number |

Flight #

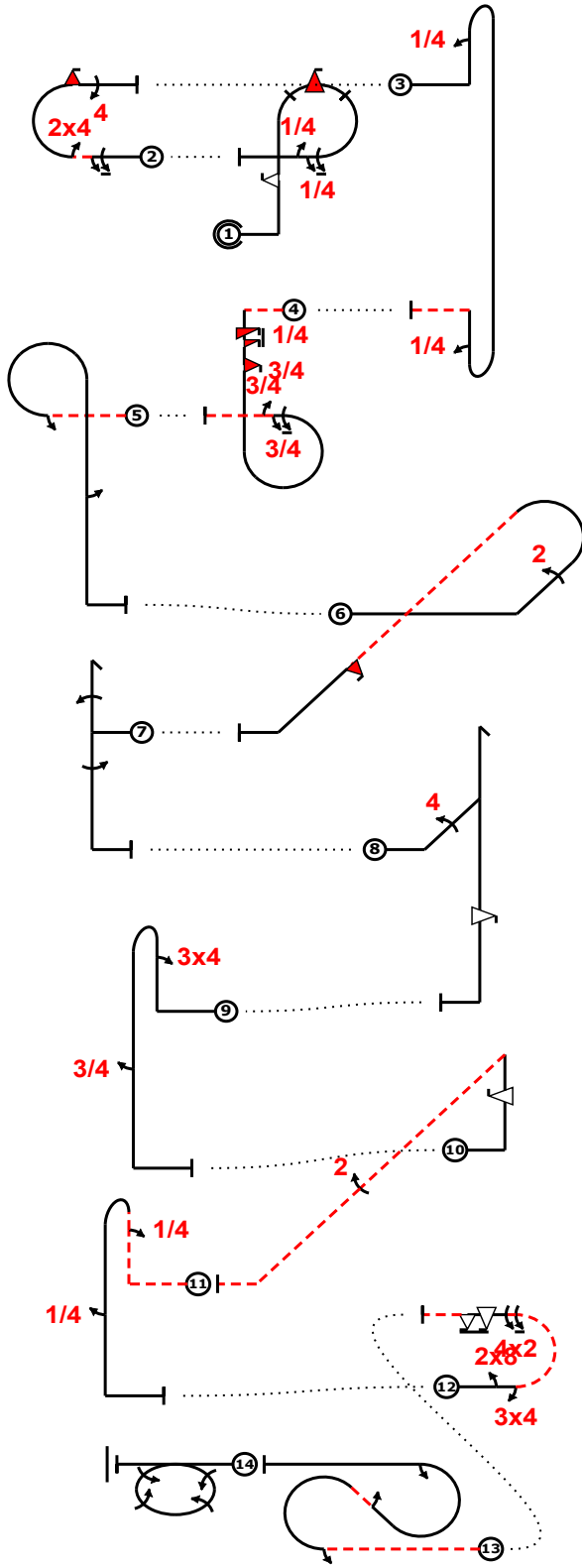

| Fig | Grade | Pos | Remarks |
|-----|-------|-----|---------|
| 1 | . | | |
| 2 | . | | |
| 3 | . | | |
| 4 | . | | |
| 5 | . | | |
| 6 | . | | |
| 7 | . | | |
| 8 | . | | |
| 9 | . | | |
| 10 | . | | |
| 11 | . | | |
| 12 | . | | |
| 13 | . | | |
| 14 | . | | |

Positioning **40**

| | | | |
|---------------|--|----------------|--|
| Too Low | | Trg Violation | |
| Too High | | Wing Rocks | |
| Interruptions | | Disqual Fig | |
| Insertions | | Other(note...) | |

"@A" . '2frp(if)5,4 (-5,0) "@D" 6,24m2if,44 (23,0) "@L" 4bb(.....)'4- (-8,0) "@E" -5is;3if.irp7, 3- (-3,0) "@L" -2p.'2... (18,1) "@G" ~+22db.....2if..' (-6,0) "@H" 1h1..' (21,0) "@B" 44dh...f ..' (-18,1) "@J" ,34b..'3..' (23,-2) "@F" fk.....',22... "@L" -,4b.,4..' (25,-1) "@C" 8,34m42;6f- (11,26) "@L" -2ac(2)2 "@I" 4j4

| Fig 1 A | K | Fig 2 D | K | Fig 3 L | K | Fig 4 E | K | Fig 5 L | K | Fig 6 G | K | Fig 7 H | K | Fig 8 B | K | Fig 9 J | K | Fig 10 F | K | Fig 11 L | K | Fig 12 C | K | Fig 13 L | K | Fig 14 I | K |
|----------|-----------|----------|-----------|---------|----------|----------|-----------|---------|----------|----------|-----------|---------|-----------|---------|-----------|---------|-----------|----------|-----------|----------|----------|----------|-----------|----------|----------|----------|-----------|
| 8.6.1.1 | 11 | 7.2.2.1 | 6 | 8.8.1.1 | 18 | 8.6.1.4 | 12 | 8.6.7.2 | 12 | 8.4.14.1 | 12 | 5.2.1.1 | 17 | 5.3.1.1 | 18 | 8.4.1.1 | 13 | 1.2.5.1 | 14 | 8.4.4.2 | 14 | 7.2.4.1 | 8 | 7.5.8.2 | 15 | 2.4.7.1 | 38 |
| 9.9.1.2 | 15 | 9.1.3.6 | 10 | 9.1.1.1 | 6 | 9.12.1.5 | 6 | 9.1.3.2 | 4 | 9.2.2.4 | 11 | 9.1.1.4 | 12 | 9.4.2.4 | 13 | 9.4.1.3 | 12 | 9.9.1.4 | 15 | 9.1.1.1 | 6 | 9.8.3.1 | 3 | 9.1.3.2 | 4 | | |
| 9.10.8.4 | 15 | 9.4.3.2 | 5 | 9.1.1.1 | 6 | 9.10.5.3 | 13 | 9.1.5.2 | 4 | 9.10.4.2 | 13 | 9.1.5.4 | 8 | 9.9.5.4 | 11 | 9.1.5.3 | 6 | 9.2.4.4 | 9 | 9.1.5.1 | 2 | 9.4.3.3 | 8 | 9.1.4.2 | 4 | | |
| 9.1.3.5 | 9 | 9.10.8.2 | 15 | | | 9.1.3.7 | 11 | | | | | | | | | | | | | | | 9.2.3.8 | 15 | 9.1.3.2 | 4 | | |
| 9.1.3.1 | 2 | 9.4.3.4 | 11 | | | 9.1.3.3 | 6 | | | | | | | | | | | | | | | 9.9.3.6 | 14 | | | | |
| | 52 | | 47 | | 6 | | 48 | | 6 | | 36 | | 37 | | 42 | | 31 | | 38 | | 6 | | 48 | | 6 | | 38 |

Pilot: **PROPOSAL B**

A/C:

Team: **FRA**

PROPOSAL B



CIVA Unlimited SEP 23
 Programme4 EAC 23 PAVULLO, ITA

Figure K
441
 Total K
481

| | | |
|-------------|--------|----------|
| Judges Name | | Flight # |
| Signature | Number | |

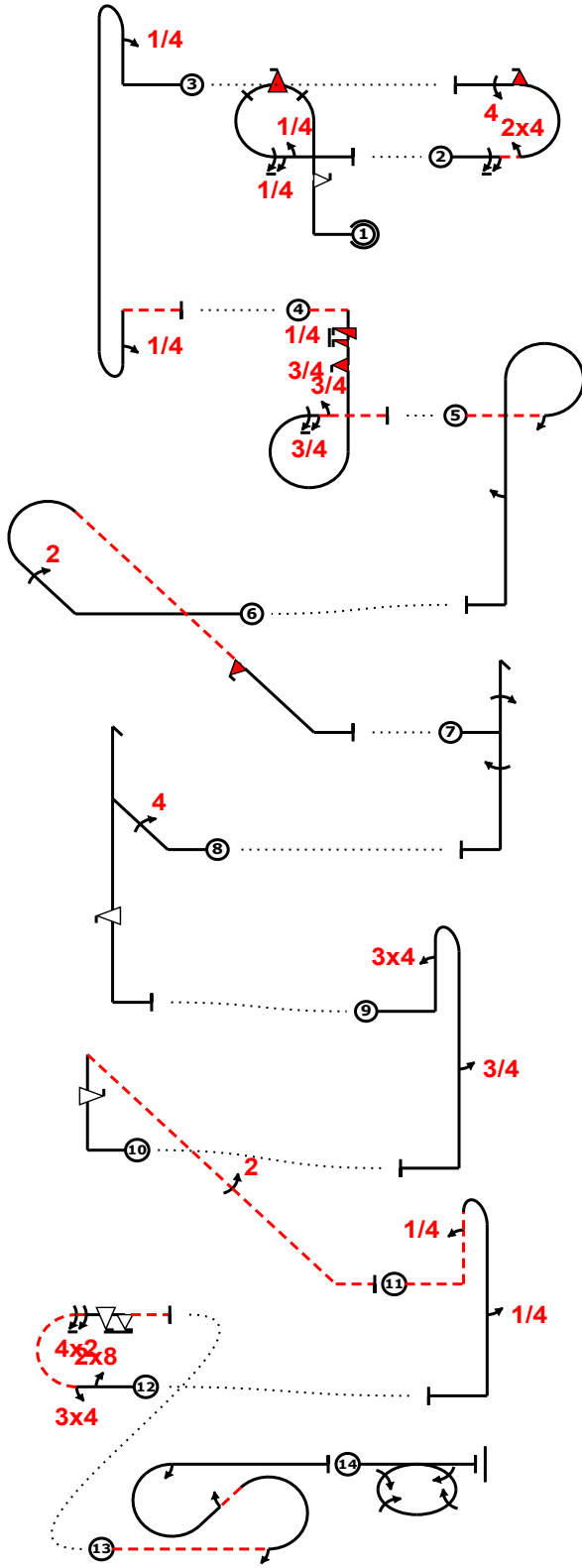
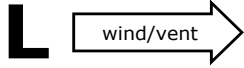

| Fig | Grade | Pos | Remarks |
|-----|-------|-----|---------|
| 1 | . | | |
| 2 | . | | |
| 3 | . | | |
| 4 | . | | |
| 5 | . | | |
| 6 | . | | |
| 7 | . | | |
| 8 | . | | |
| 9 | . | | |
| 10 | . | | |
| 11 | . | | |
| 12 | . | | |
| 13 | . | | |
| 14 | . | | |

Positioning
40

| | | | |
|---------------|--|----------------|--|
| Too Low | | Trg Violation | |
| Too High | | Wing Rocks | |
| Interruptions | | Disqual Fig | |
| Insertions | | Other(note...) | |

"@A" . '2frp(if)5,4 (-5,0) "@D" 6,24m2if,44 (23,0) "@L" 4bb(.....)'4- (-8,0) "@E" -5is;3if.irp7, 3- (-3,0) "@L" -2p.'2... (18,1) "@G" ~+22db.....2if..' (-6,0) "@H" 1h1..' (21,0) "@B" 44dh...f ..' (-18,1) "@J" ,34b..'3..' (23,-2) "@F" fk.....',22...' "@L" -,4b.,',4..' (25,-1) "@C" 8,34m42;6f- (11,26) "@L" -2ac(2)2 "@I" 4j4

| Fig 1 A | K | Fig 2 D | K | Fig 3 L | K | Fig 4 E | K | Fig 5 L | K | Fig 6 G | K | Fig 7 H | K | Fig 8 B | K | Fig 9 J | K | Fig 10 F | K | Fig 11 L | K | Fig 12 C | K | Fig 13 L | K | Fig 14 I | K |
|----------|-----------|----------|-----------|---------|----------|-----------|-----------|---------|----------|----------|-----------|---------|-----------|---------|-----------|---------|-----------|----------|-----------|----------|----------|----------|-----------|----------|----------|----------|-----------|
| 8.6.1.1 | 11 | 7.2.2.1 | 6 | 8.8.1.1 | 18 | 8.6.1.4 | 12 | 8.6.7.2 | 12 | 8.4.14.1 | 12 | 5.2.1.1 | 17 | 5.3.1.1 | 18 | 8.4.1.1 | 13 | 1.2.5.1 | 14 | 8.4.4.2 | 14 | 7.2.4.1 | 8 | 7.5.8.2 | 15 | 2.4.7.1 | 38 |
| 9.9.1.2 | 15 | 9.1.3.6 | 10 | 9.1.1.1 | 6 | 9.1.2.1.5 | 6 | 9.1.3.2 | 4 | 9.2.2.4 | 11 | 9.1.1.4 | 12 | 9.4.2.4 | 13 | 9.4.1.3 | 12 | 9.9.1.4 | 15 | 9.1.1.1 | 6 | 9.8.3.1 | 3 | 9.1.3.2 | 4 | | |
| 9.10.8.4 | 15 | 9.4.3.2 | 5 | 9.1.1.1 | 6 | 9.10.5.3 | 13 | 9.1.5.2 | 4 | 9.10.4.2 | 13 | 9.1.5.4 | 8 | 9.9.5.4 | 11 | 9.1.5.3 | 6 | 9.2.4.4 | 9 | 9.1.5.1 | 2 | 9.4.3.3 | 8 | 9.1.4.2 | 4 | | |
| 9.1.3.5 | 9 | 9.10.8.2 | 15 | | | 9.1.3.7 | 11 | | | | | | | | | | | | | | | 9.2.3.8 | 15 | 9.1.3.2 | 4 | | |
| 9.1.3.1 | 2 | 9.4.3.4 | 11 | | | 9.1.3.3 | 6 | | | | | | | | | | | | | | | 9.9.3.6 | 14 | | | | |
| | 52 | | 47 | | 6 | | 48 | | 6 | | 36 | | 37 | | 42 | | 31 | | 38 | | 6 | | 48 | | 6 | | 38 |

Pilot: **PROPOSAL B**

A/C:

Team: **FRA**

PROPOSAL C



CIVA Unlimited SEP 23
 Programme4 EAC 23 PAVULLO, ITA

Figure K
441
 Total K
481

Judges Name
 Signature Number

Flight #

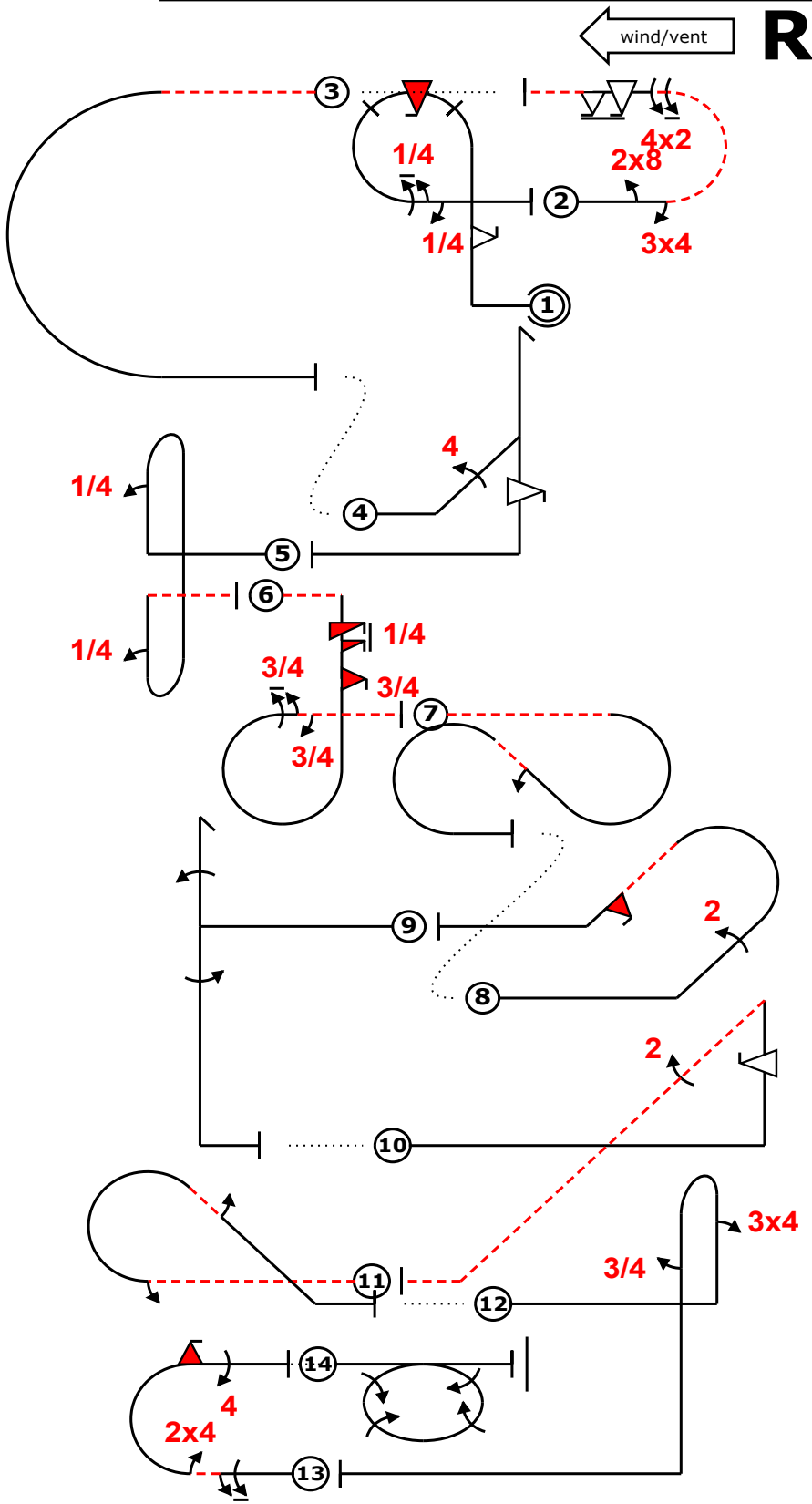

| Fig | Grade | Pos | Remarks |
|-----|-------|-----|---------|
| 1 | . | | |
| 2 | . | | |
| 3 | . | | |
| 4 | . | | |
| 5 | . | | |
| 6 | . | | |
| 7 | . | | |
| 8 | . | | |
| 9 | . | | |
| 10 | . | | |
| 11 | . | | |
| 12 | . | | |
| 13 | . | | |
| 14 | . | | |

Positioning
40

| | | | |
|---------------|--|----------------|--|
| Too Low | | Trg Violation | |
| Too High | | Wing Rocks | |
| Interruptions | | Disqual Fig | |
| Insertions | | Other(note...) | |

ed "@A" -,2frp(if)5,4 "@C" 8,34m42;6f- (-9,0) "@L" 16% -a (-1,10) "@B" 44dhf'++~+~ "@L" ~4bb(')4-
 "@E" ~5is;3ifirp7,3- "@L" ~~~~~iac('2)+~~~~~ (-6,12) "@G" 22db2if++ "@H" +++h1...' (5,0) "
 @F" ~+++++fk,22....' - "@L" ~2c2 (4,0) "@J" ~+++,34b'~,3...'+++++~ "@D" 6,24m2if,44 (-2,0) "@I"
 4j4

| Fig 1 A | K | Fig 2 C | K | Fig 3 L | K | Fig 4 B | K | Fig 5 L | K | Fig 6 E | K | Fig 7 L | K | Fig 8 G | K | Fig 9 H | K | Fig 10 F | K | Fig 11 L | K | Fig 12 J | K | Fig 13 D | K | Fig 14 I | K |
|----------|-----------|---------|-----------|---------|----------|---------|-----------|---------|----------|----------|-----------|---------|----------|----------|-----------|---------|-----------|----------|-----------|----------|----------|----------|-----------|----------|-----------|----------|-----------|
| 8.6.1.1 | 11 | 7.2.4.1 | 8 | 7.2.1.4 | 6 | 5.3.1.1 | 18 | 8.8.1.1 | 18 | 8.6.1.4 | 12 | 7.5.2.4 | 15 | 8.4.1.4 | 12 | 5.2.1.1 | 17 | 1.2.5.1 | 14 | 8.5.8.2 | 11 | 8.4.1.1 | 13 | 7.2.2.1 | 6 | 2.4.7.1 | 38 |
| 9.9.1.2 | 15 | 9.8.3.1 | 3 | | | 9.4.2.4 | 13 | 9.1.1.1 | 6 | 9.12.1.5 | 6 | 9.1.2.2 | 6 | 9.2.2.4 | 11 | 9.1.1.4 | 12 | 9.9.1.4 | 15 | 9.1.3.2 | 4 | 9.4.1.3 | 12 | 9.1.3.6 | 10 | | |
| 9.10.8.4 | 15 | 9.4.3.3 | 8 | | | 9.9.5.4 | 11 | 9.1.1.1 | 6 | 9.10.5.3 | 13 | | | 9.10.4.2 | 13 | 9.1.5.4 | 8 | 9.2.4.4 | 9 | 9.1.4.2 | 4 | 9.1.5.3 | 6 | 9.4.3.2 | 5 | | |
| 9.1.3.5 | 9 | 9.2.3.8 | 15 | | | | | | | 9.1.3.7 | 11 | | | | | | | | | | | | | 9.10.8.2 | 15 | | |
| 9.1.3.1 | 2 | 9.9.3.6 | 14 | | | | | | | 9.1.3.3 | 6 | | | | | | | | | | | | | 9.4.3.4 | 11 | | |
| | 52 | | 48 | | 6 | | 42 | | 6 | | 48 | | 6 | | 36 | | 37 | | 38 | | 6 | | 31 | | 47 | | 38 |

Pilot: **PROPOSAL C**

A/C:

Team: **GER**

PROPOSAL C



CIVA Unlimited SEP 23
 Programme4 EAC 23 PAVULLO, ITA

Figure K
441
 Total K
481

| | | |
|-------------|--------|----------|
| Judges Name | | Flight # |
| Signature | Number | |

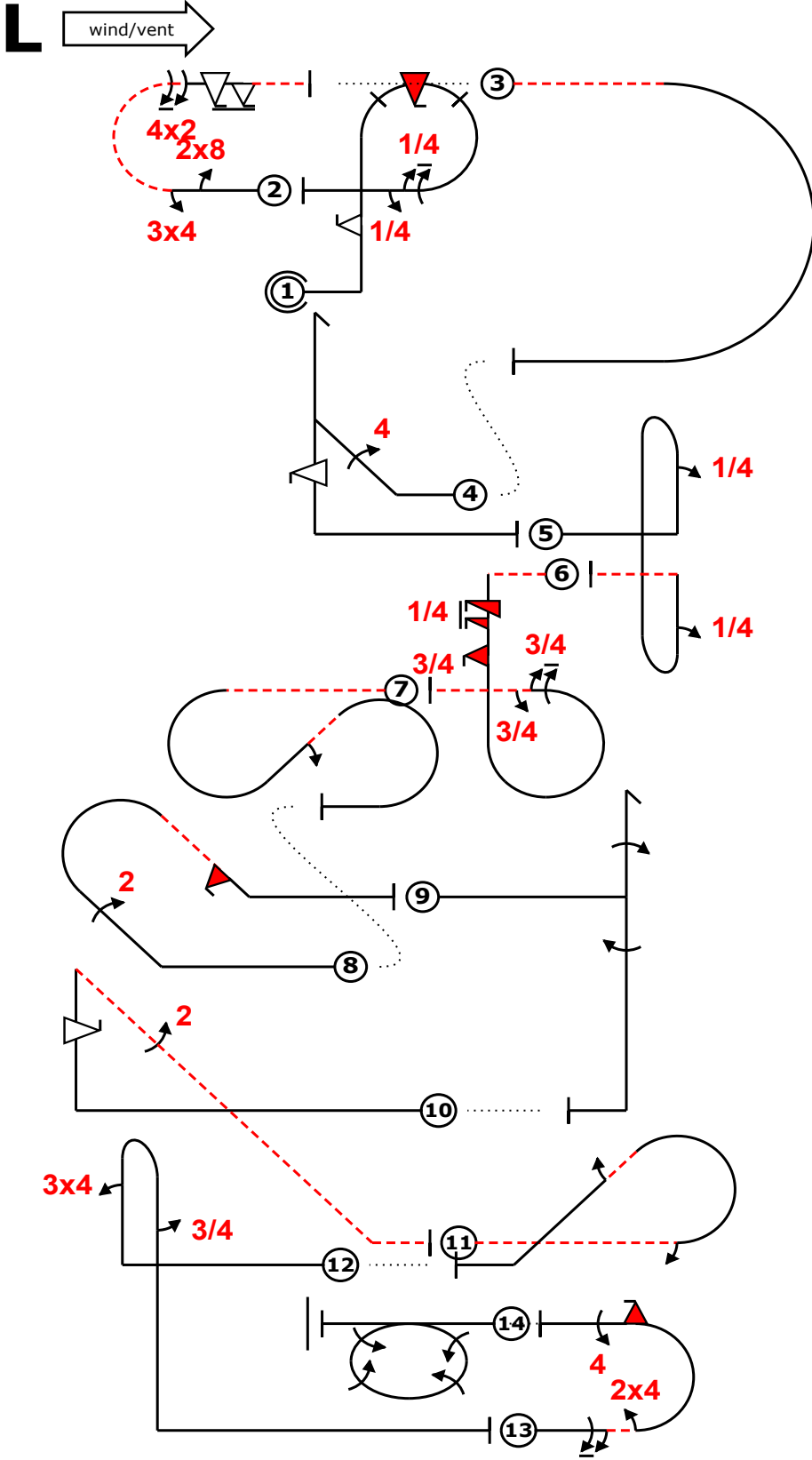

| Fig | Grade | Pos | Remarks |
|-----|-------|-----|---------|
| 1 | . | | |
| 2 | . | | |
| 3 | . | | |
| 4 | . | | |
| 5 | . | | |
| 6 | . | | |
| 7 | . | | |
| 8 | . | | |
| 9 | . | | |
| 10 | . | | |
| 11 | . | | |
| 12 | . | | |
| 13 | . | | |
| 14 | . | | |

Positioning
40

| | | | |
|---------------|--|----------------|--|
| Too Low | | Trg Violation | |
| Too High | | Wing Rocks | |
| Interruptions | | Disqual Fig | |
| Insertions | | Other(note...) | |

ed "@A" .,2frp(if)5,4 "@C" 8,34m42;6f- (-9,0) "@L" 16% -a (-1,10) "@B" 44dhf'++~ "@L" ~4bb(')4-
 "@E" -5is;3ifirp7,3- "@L" -~~~~iac('2)+~~~~~ (-6,12) "@G" 22db2if++ "@H" +++h1...' (5,0) "
 "@F" ~+++++fk,22.....' "@L" -2c2 (4,0) "@J" ~+++,34b`',3...'+++++~ "@D" 6,24m2if,44 (-2,0) "@I"
 4j4

| Fig 1 A | K | Fig 2 C | K | Fig 3 L | K | Fig 4 B | K | Fig 5 L | K | Fig 6 E | K | Fig 7 L | K | Fig 8 G | K | Fig 9 H | K | Fig 10 F | K | Fig 11 L | K | Fig 12 J | K | Fig 13 D | K | Fig 14 I | K |
|----------|-----------|---------|-----------|---------|----------|---------|-----------|---------|----------|----------|-----------|---------|----------|-----------|-----------|---------|-----------|----------|-----------|----------|----------|----------|-----------|----------|-----------|----------|-----------|
| 8.6.1.1 | 11 | 7.2.4.1 | 8 | 7.2.1.4 | 6 | 5.3.1.1 | 18 | 8.8.1.1 | 18 | 8.6.1.4 | 12 | 7.5.2.4 | 15 | 8.4.1.4.1 | 12 | 5.2.1.1 | 17 | 1.2.5.1 | 14 | 8.5.8.2 | 11 | 8.4.1.1 | 13 | 7.2.2.1 | 6 | 2.4.7.1 | 38 |
| 9.9.1.2 | 15 | 9.8.3.1 | 3 | | | 9.4.2.4 | 13 | 9.1.1.1 | 6 | 9.12.1.5 | 6 | 9.1.2.2 | 6 | 9.2.2.4 | 11 | 9.1.1.4 | 12 | 9.9.1.4 | 15 | 9.1.3.2 | 4 | 9.4.1.3 | 12 | 9.1.3.6 | 10 | | |
| 9.10.8.4 | 15 | 9.4.3.3 | 8 | | | 9.9.5.4 | 11 | 9.1.1.1 | 6 | 9.10.5.3 | 13 | | | 9.10.4.2 | 13 | 9.1.5.4 | 8 | 9.2.4.4 | 9 | 9.1.4.2 | 4 | 9.1.5.3 | 6 | 9.4.3.2 | 5 | | |
| 9.1.3.5 | 9 | 9.2.3.8 | 15 | | | | | | | 9.1.3.7 | 11 | | | | | | | | | | | | | 9.10.8.2 | 15 | | |
| 9.1.3.1 | 2 | 9.9.3.6 | 14 | | | | | | | 9.1.3.3 | 6 | | | | | | | | | | | | 9.4.3.4 | 11 | | | |
| | 52 | | 48 | | 6 | | 42 | | 6 | | 48 | | 6 | | 36 | | 37 | | 38 | | 6 | | 31 | | 47 | | 38 |

Pilot: **PROPOSAL C**

A/C:

Team: **GER**

PROPOSAL D



CIVA Unlimited SEP 23
 Programme4 EAC 23 PAVULLO, ITA

Figure K
441
 Total K
481

| | |
|-------------|--------|
| Judges Name | |
| Signature | Number |

| |
|----------|
| Flight # |
|----------|

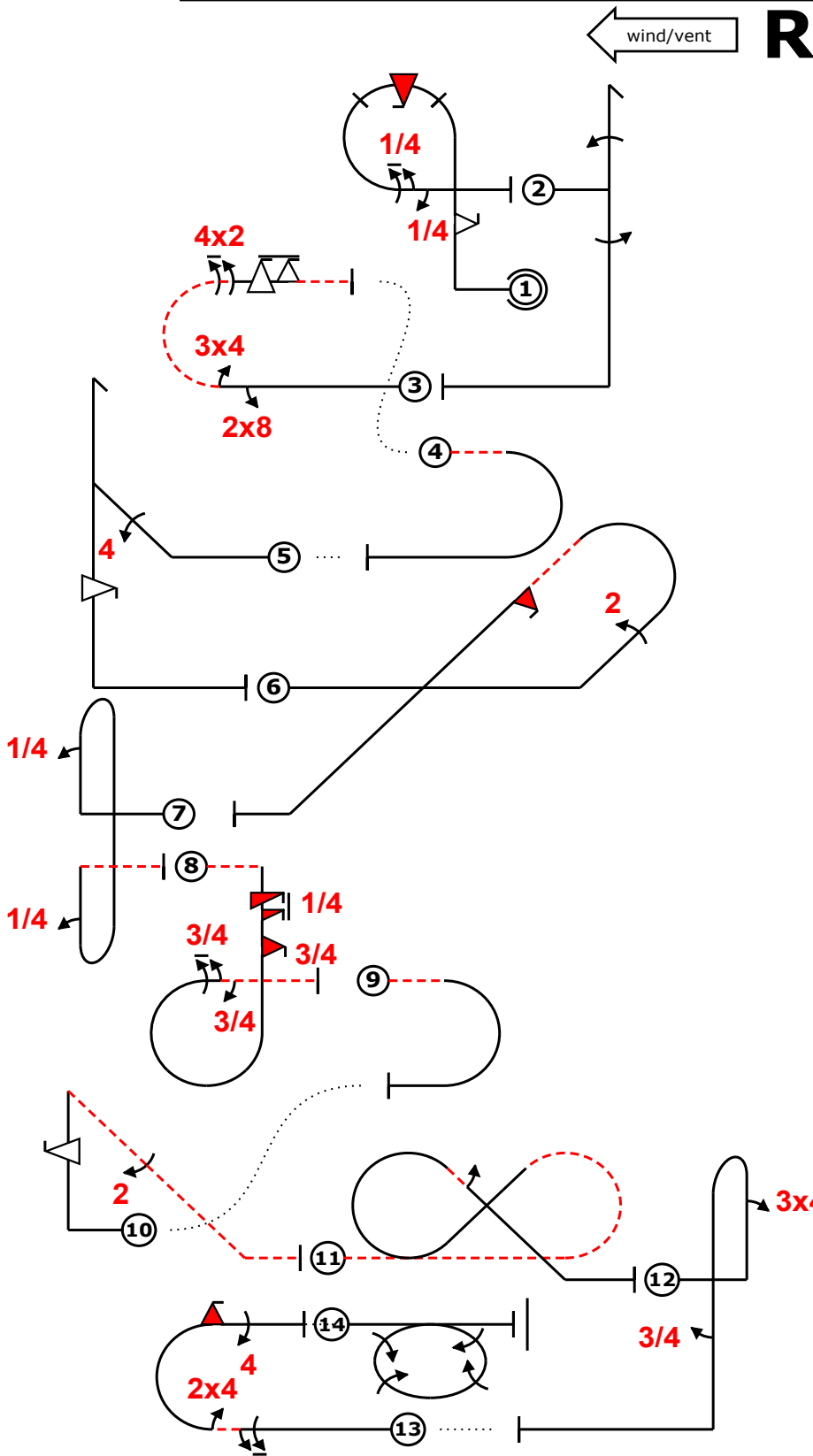

| Fig | Grade | Pos | Remarks |
|-----|-------|-----|---------|
| 1 | . | | |
| 2 | . | | |
| 3 | . | | |
| 4 | . | | |
| 5 | . | | |
| 6 | . | | |
| 7 | . | | |
| 8 | . | | |
| 9 | . | | |
| 10 | . | | |
| 11 | . | | |
| 12 | . | | |
| 13 | . | | |
| 14 | . | | |

Positioning
40

| | | | |
|---------------|--|----------------|--|
| Too Low | | Trg Violation | |
| Too High | | Wing Rocks | |
| Interruptions | | Disqual Fig | |
| Insertions | | Other(note...) | |

ed "@A" .,2frp(if)5,4 "@H" 1h1...+~ "@C" ..'8,34m42;6f- (2,13) "@L" -a++ (-2,0) "@B" +44dh.'f.''+
 +~ "@G" +++22db2if..... > "@L" 4bb(')4- "@E" -5is;3ifirp7,3- 2> "@L" -a (-14,11) "@F" fk,22'-'
 "@L" -cc2+' "@J" ^+,34b.'',3,+~ (-4,0) "@D" ..6,24m2if,44 (-2,0) "@I" 4j4

| Fig 1 A | K | Fig 2 H | K | Fig 3 C | K | Fig 4 L | K | Fig 5 B | K | Fig 6 G | K | Fig 7 L | K | Fig 8 E | K | Fig 9 L | K | Fig 10 F | K | Fig 11 L | K | Fig 12 J | K | Fig 13 D | K | Fig 14 I | K |
|----------|-----------|---------|-----------|---------|-----------|---------|----------|---------|-----------|----------|-----------|---------|----------|----------|-----------|---------|----------|----------|-----------|----------|----------|----------|-----------|----------|-----------|----------|-----------|
| 8.6.1.1 | 11 | 5.2.1.1 | 17 | 7.2.4.1 | 8 | 7.2.1.4 | 6 | 5.3.1.1 | 18 | 8.4.14.1 | 12 | 8.8.1.1 | 18 | 8.6.1.4 | 12 | 7.2.1.4 | 6 | 1.2.5.1 | 14 | 7.8.2.2 | 20 | 8.4.1.1 | 13 | 7.2.2.1 | 6 | 2.4.7.1 | 38 |
| 9.9.1.2 | 15 | 9.1.1.4 | 12 | 9.8.3.1 | 3 | | | 9.4.2.4 | 13 | 9.2.2.4 | 11 | 9.1.1.1 | 6 | 9.12.1.5 | 6 | | | 9.9.1.4 | 15 | 9.1.4.2 | 4 | 9.4.1.3 | 12 | 9.1.3.6 | 10 | | |
| 9.10.8.4 | 15 | 9.1.5.4 | 8 | 9.4.3.3 | 8 | | | 9.9.5.4 | 11 | 9.10.4.2 | 13 | 9.1.1.1 | 6 | 9.10.5.3 | 13 | | | 9.2.4.4 | 9 | | | 9.1.5.3 | 6 | 9.4.3.2 | 5 | | |
| 9.1.3.5 | 9 | | | 9.2.3.8 | 15 | | | | | | | | | 9.1.3.7 | 11 | | | | | | | | | 9.10.8.2 | 15 | | |
| 9.1.3.1 | 2 | | | 9.9.3.6 | 14 | | | | | | | | | 9.1.3.3 | 6 | | | | | | | | | 9.4.3.4 | 11 | | |
| | 52 | | 37 | | 48 | | 6 | | 42 | | 36 | | 6 | | 48 | | 6 | | 38 | | 6 | | 31 | | 47 | | 38 |

Pilot: **PROPOSAL D**

A/C:

Team: **GER**

PROPOSAL D



CIVA Unlimited SEP 23
 Programme4 EAC 23 PAVULLO, ITA

Figure K
441
 Total K
481

| | | |
|-------------|--------|----------|
| Judges Name | | Flight # |
| Signature | Number | |

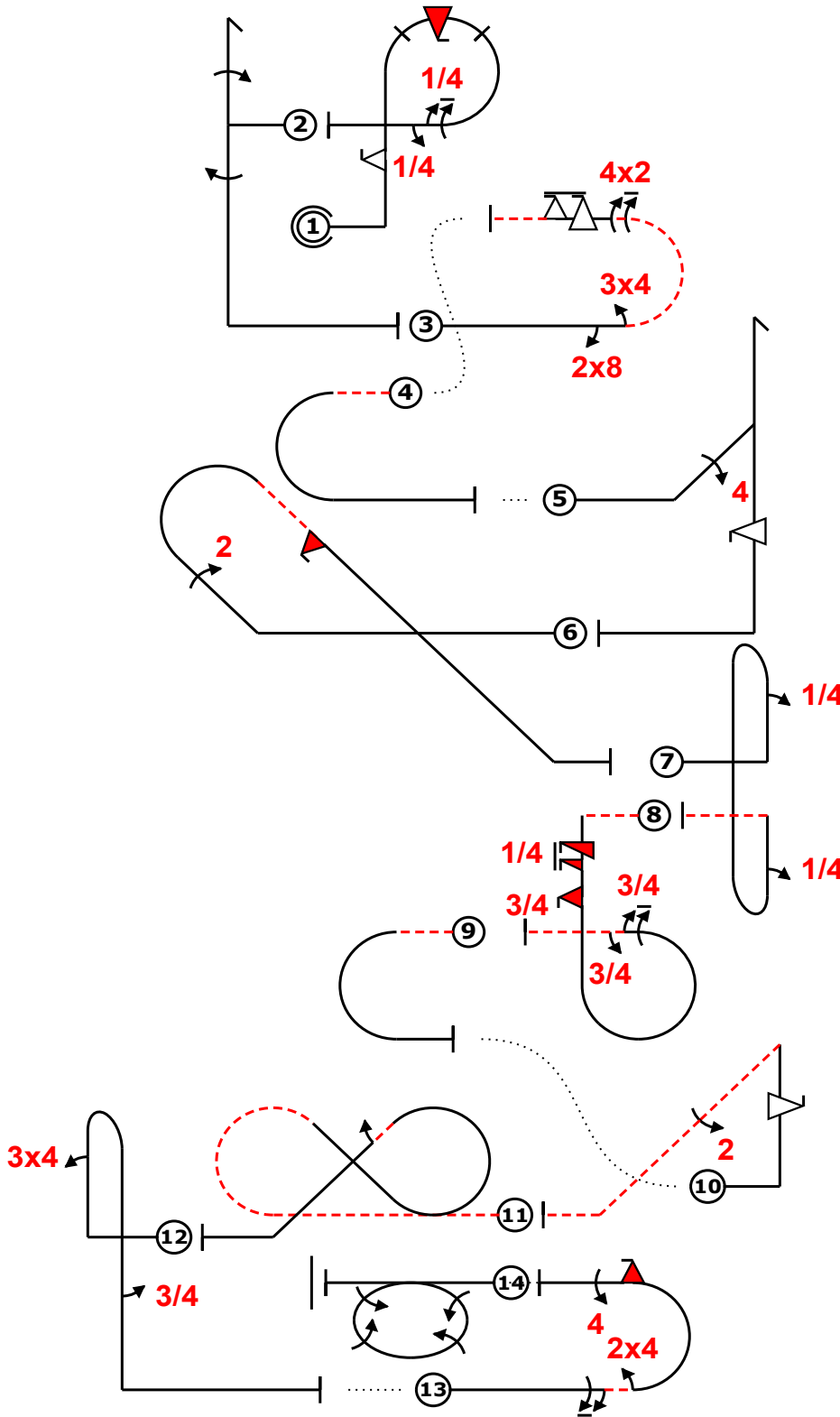
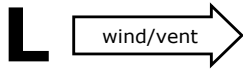

| Fig | Grade | Pos | Remarks |
|-----|-------|-----|---------|
| 1 | . | | |
| 2 | . | | |
| 3 | . | | |
| 4 | . | | |
| 5 | . | | |
| 6 | . | | |
| 7 | . | | |
| 8 | . | | |
| 9 | . | | |
| 10 | . | | |
| 11 | . | | |
| 12 | . | | |
| 13 | . | | |
| 14 | . | | |

Positioning
40

| | | | |
|---------------|--|----------------|--|
| Too Low | | Trg Violation | |
| Too High | | Wing Rocks | |
| Interruptions | | Disqual Fig | |
| Insertions | | Other(note...) | |

ed "@A" .,2frp(if)5,4 "@H" 1h1...+~ "@C" ..'8,34m42;6f- (2,13) "@L" -a++ (-2,0) "@B" +44dh.'f.''+
 +- "@G" +++22db2if..... 2> "@L" 4bb(')4- "@E" -5is;3ifirp7,3- 2> "@L" -a (-14,11) "@F" fk,22'-
 "@L" -cc2+' "@J" '+,34b.'',3,+~ (-4,0) "@D" ..6,24m2if,44 (-2,0) "@I" 4j4

| Fig 1 A | K | Fig 2 H | K | Fig 3 C | K | Fig 4 L | K | Fig 5 B | K | Fig 6 G | K | Fig 7 L | K | Fig 8 E | K | Fig 9 L | K | Fig 10 F | K | Fig 11 L | K | Fig 12 J | K | Fig 13 D | K | Fig 14 I | K |
|----------|-----------|---------|-----------|---------|-----------|---------|----------|---------|-----------|----------|-----------|---------|----------|----------|-----------|---------|----------|----------|-----------|----------|----------|----------|-----------|----------|-----------|----------|-----------|
| 8.6.1.1 | 11 | 5.2.1.1 | 17 | 7.2.4.1 | 8 | 7.2.1.4 | 6 | 5.3.1.1 | 18 | 8.4.14.1 | 12 | 8.8.1.1 | 18 | 8.6.1.4 | 12 | 7.2.1.4 | 6 | 1.2.5.1 | 14 | 7.8.2.2 | 20 | 8.4.1.1 | 13 | 7.2.2.1 | 6 | 2.4.7.1 | 38 |
| 9.9.1.2 | 15 | 9.1.1.4 | 12 | 9.8.3.1 | 3 | | | 9.4.2.4 | 13 | 9.2.2.4 | 11 | 9.1.1.1 | 6 | 9.12.1.5 | 6 | | | 9.9.1.4 | 15 | 9.1.4.2 | 4 | 9.4.1.3 | 12 | 9.1.3.6 | 10 | | |
| 9.10.8.4 | 15 | 9.1.5.4 | 8 | 9.4.3.3 | 8 | | | 9.9.5.4 | 11 | 9.10.4.2 | 13 | 9.1.1.1 | 6 | 9.10.5.3 | 13 | | | 9.2.4.4 | 9 | | | 9.1.5.3 | 6 | 9.4.3.2 | 5 | | |
| 9.1.3.5 | 9 | | | 9.2.3.8 | 15 | | | | | | | | | 9.1.3.7 | 11 | | | | | | | | | 9.10.8.2 | 15 | | |
| 9.1.3.1 | 2 | | | 9.9.3.6 | 14 | | | | | | | | | 9.1.3.3 | 6 | | | | | | | | | 9.4.3.4 | 11 | | |
| | 52 | | 37 | | 48 | | 6 | | 42 | | 36 | | 6 | | 48 | | 6 | | 38 | | 6 | | 31 | | 47 | | 38 |

Pilot: **PROPOSAL D**

A/C:

Team: **GER**

PROPOSAL E



| | | |
|------------|---------------------|--------|
| CIVA | Unlimited | SEP 23 |
| Programme4 | EAC 23 PAVULLO, ITA | |

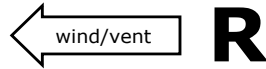
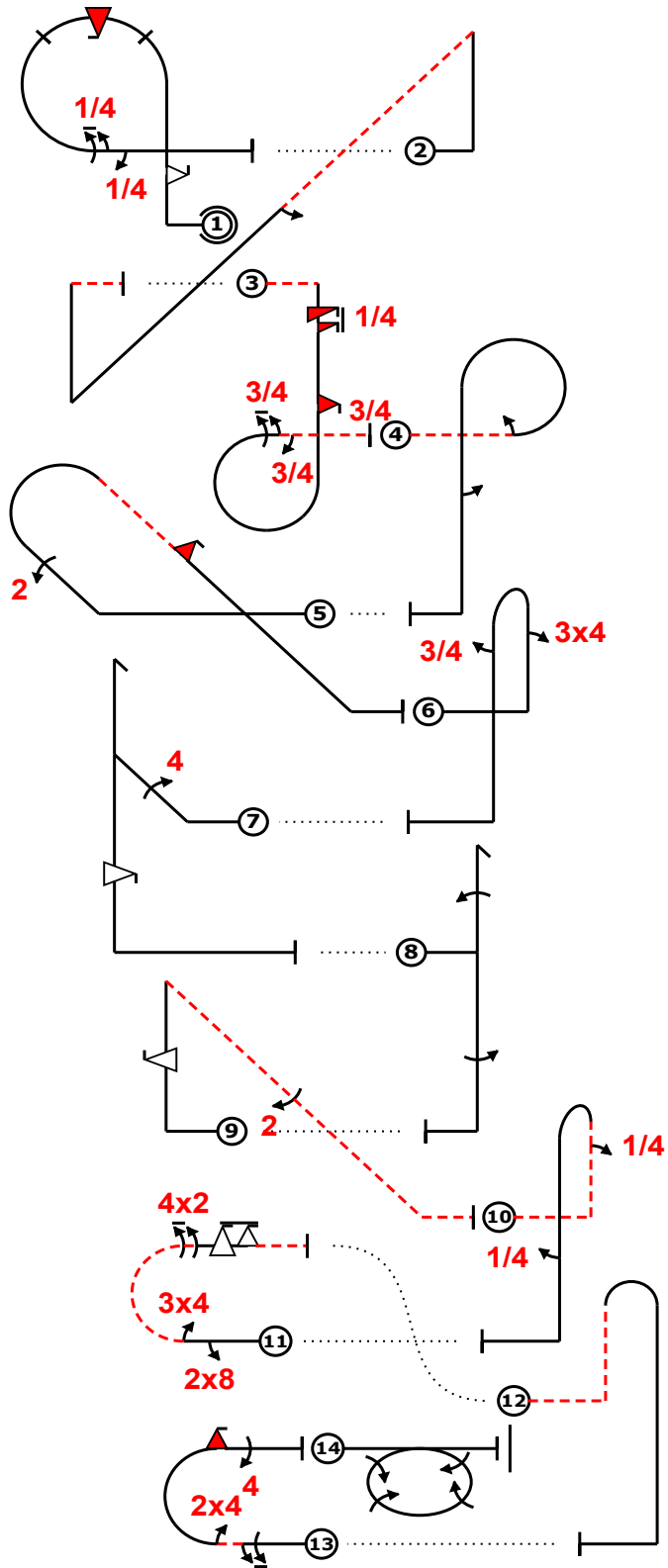

Figure K
441
Total K
481

| | |
|-------------|--------|
| Judges Name | |
| Signature | Number |

Flight #



| Fig | Grade | Pos | Remarks |
|-----|-------|-----|---------|
| 1 | . | | |
| 2 | . | | |
| 3 | . | | |
| 4 | . | | |
| 5 | . | | |
| 6 | . | | |
| 7 | . | | |
| 8 | . | | |
| 9 | . | | |
| 10 | . | | |
| 11 | . | | |
| 12 | . | | |
| 13 | . | | |
| 14 | . | | |

Positioning
40

| | | | |
|---------------|--|----------------|--|
| Too Low | | Trg Violation | |
| Too High | | Wing Rocks | |
| Interruptions | | Disqual Fig | |
| Insertions | | Other(note...) | |

ed "@A" 4% ``+',2f`rp(if)5,4~ (9,0) "@L" `+n(....'2.....')- (6,0) "@E" -5is.!'3ifirp7,3- "@L" -2p' 2..!' (-3,0) "@G" ~+22db.2if.....! "@j" 1% ,34b`'',3... (-8,0) "@B" ,44dh..f.'++++ (5,0) "@H" '1h. '1.' (-11,0) "@F" f''k...22.- "@L" -,4b.'.4. (-12,0) "@C" 8,34m42;6f- (12,13) "@L" -b...' (-16,0) "@D" 6,24m2if,44 "@I" 4j4

| Fig 1 A | K | Fig 2 L | K | Fig 3 E | K | Fig 4 L | K | Fig 5 G | K | Fig 6 J | K | Fig 7 B | K | Fig 8 H | K | Fig 9 F | K | Fig 10 L | K | Fig 11 C | K | Fig 12 L | K | Fig 13 D | K | Fig 14 I | K |
|----------|-----------|----------|----------|----------|-----------|---------|----------|----------|-----------|---------|-----------|---------|-----------|---------|-----------|---------|-----------|----------|----------|----------|-----------|----------|----------|----------|-----------|----------|-----------|
| 8.6.1.1 | 11 | 1.3.11.1 | 20 | 8.6.1.4 | 12 | 8.6.7.2 | 12 | 8.4.14.1 | 12 | 8.4.1.1 | 13 | 5.3.1.1 | 18 | 5.2.1.1 | 17 | 1.2.5.1 | 14 | 8.4.4.2 | 14 | 7.2.4.1 | 8 | 8.4.4.2 | 14 | 7.2.2.1 | 6 | 2.4.7.1 | 38 |
| 9.9.1.2 | 15 | 9.1.4.2 | 4 | 9.12.1.5 | 6 | 9.1.3.2 | 4 | 9.2.2.4 | 11 | 9.4.1.3 | 12 | 9.4.2.4 | 13 | 9.1.1.4 | 12 | 9.9.1.4 | 15 | 9.1.1.1 | 6 | 9.8.3.1 | 3 | | | 9.1.3.6 | 10 | | |
| 9.10.8.4 | 15 | | | 9.10.5.3 | 13 | 9.1.5.2 | 4 | 9.10.4.2 | 13 | 9.1.5.3 | 6 | 9.9.5.4 | 11 | 9.1.5.4 | 8 | 9.2.4.4 | 9 | 9.1.5.1 | 2 | 9.4.3.3 | 8 | | | 9.4.3.2 | 5 | | |
| 9.1.3.5 | 9 | | | 9.1.3.7 | 11 | | | | | | | | | | | | | | | 9.2.3.8 | 15 | | | 9.10.8.2 | 15 | | |
| 9.1.3.1 | 2 | | | 9.1.3.3 | 6 | | | | | | | | | | | | | | | 9.9.3.6 | 14 | | | 9.4.3.4 | 11 | | |
| | 52 | | 6 | | 48 | | 6 | | 36 | | 31 | | 42 | | 37 | | 38 | | 6 | | 48 | | 6 | | 47 | | 38 |

Pilot: **PROPOSAL E**

A/C:

Team: **HUN**

PROPOSAL E



CIVA Unlimited SEP 23
 Programme4 EAC 23 PAVULLO, ITA

Figure K
441
 Total K
481

| | | |
|-------------|--------|----------|
| Judges Name | | Flight # |
| Signature | Number | |

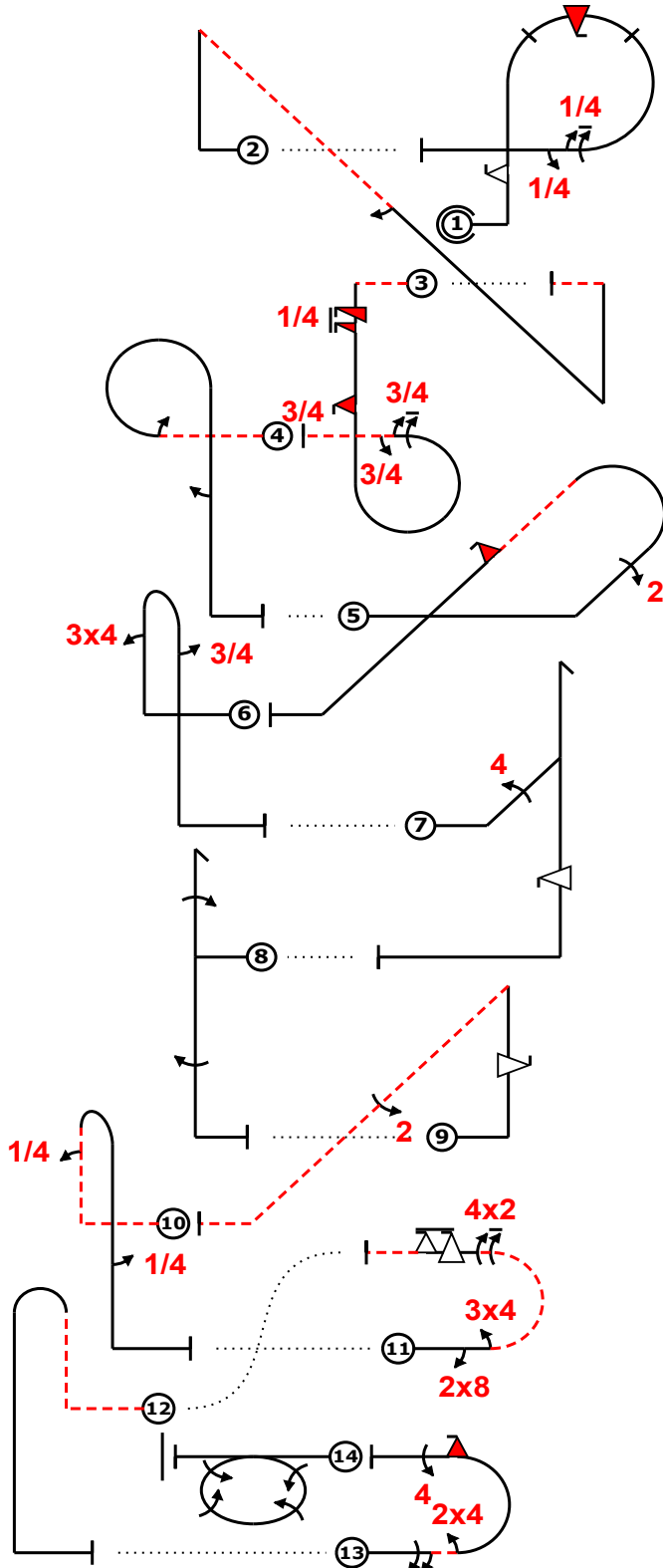
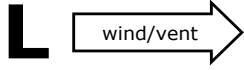

| Fig | Grade | Pos | Remarks |
|-----|-------|-----|---------|
| 1 | . | | |
| 2 | . | | |
| 3 | . | | |
| 4 | . | | |
| 5 | . | | |
| 6 | . | | |
| 7 | . | | |
| 8 | . | | |
| 9 | . | | |
| 10 | . | | |
| 11 | . | | |
| 12 | . | | |
| 13 | . | | |
| 14 | . | | |

Positioning **40**

| | | | |
|---------------|--|----------------|--|
| Too Low | | Trg Violation | |
| Too High | | Wing Rocks | |
| Interruptions | | Disqual Fig | |
| Insertions | | Other(note...) | |

ed "@A" 4% `+',2f`rp(if)5,4~ (9,0) "@L" `+n(....'2.....')- (6,0) "@E" -5is.;3ifirp7,3- "@L" -2p' 2..!' (-3,0) "@G" ~+22db.2if....." "@j" 1% ,34b`'',3... (-8,0) "@B" ,44dh..f.'++++ (5,0) "@H" '1h. '1.' (-11,0) "@F" f''k...22...- "@L" -,4b.',4. (-12,0) "@C" 8,34m42;6f- (12,13) "@L" -b...' (-16,0) "@D" 6,24m2if,44 "@I" 4j4

| Fig 1 A | K | Fig 2 L | K | Fig 3 E | K | Fig 4 L | K | Fig 5 G | K | Fig 6 J | K | Fig 7 B | K | Fig 8 H | K | Fig 9 F | K | Fig 10 L | K | Fig 11 C | K | Fig 12 L | K | Fig 13 D | K | Fig 14 I | K |
|----------|-----------|----------|----------|----------|-----------|---------|----------|----------|-----------|---------|-----------|---------|-----------|---------|-----------|---------|-----------|----------|----------|----------|-----------|----------|----------|----------|-----------|----------|-----------|
| 8.6.1.1 | 11 | 1.3.11.1 | 20 | 8.6.1.4 | 12 | 8.6.7.2 | 12 | 8.4.14.1 | 12 | 8.4.1.1 | 13 | 5.3.1.1 | 18 | 5.2.1.1 | 17 | 1.2.5.1 | 14 | 8.4.4.2 | 14 | 7.2.4.1 | 8 | 8.4.4.2 | 14 | 7.2.2.1 | 6 | 2.4.7.1 | 38 |
| 9.9.1.2 | 15 | 9.1.4.2 | 4 | 9.12.1.5 | 6 | 9.1.3.2 | 4 | 9.2.2.4 | 11 | 9.4.1.3 | 12 | 9.4.2.4 | 13 | 9.1.1.4 | 12 | 9.9.1.4 | 15 | 9.1.1.1 | 6 | 9.8.3.1 | 3 | | | 9.1.3.6 | 10 | | |
| 9.10.8.4 | 15 | | | 9.10.5.3 | 13 | 9.1.5.2 | 4 | 9.10.4.2 | 13 | 9.1.5.3 | 6 | 9.9.5.4 | 11 | 9.1.5.4 | 8 | 9.2.4.4 | 9 | 9.1.5.1 | 2 | 9.4.3.3 | 8 | | | 9.4.3.2 | 5 | | |
| 9.1.3.5 | 9 | | | 9.1.3.7 | 11 | | | | | | | | | | | | | | | 9.2.3.8 | 15 | | | 9.10.8.2 | 15 | | |
| 9.1.3.1 | 2 | | | 9.1.3.3 | 6 | | | | | | | | | | | | | | | 9.9.3.6 | 14 | | | 9.4.3.4 | 11 | | |
| | 52 | | 6 | | 48 | | 6 | | 36 | | 31 | | 42 | | 37 | | 38 | | 6 | | 48 | | 6 | | 47 | | 38 |

PROPOSAL F



| | | |
|------------|---------------------|--------|
| CIVA | Unlimited | SEP 23 |
| Programme4 | EAC 23 PAVULLO, ITA | |

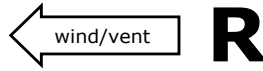
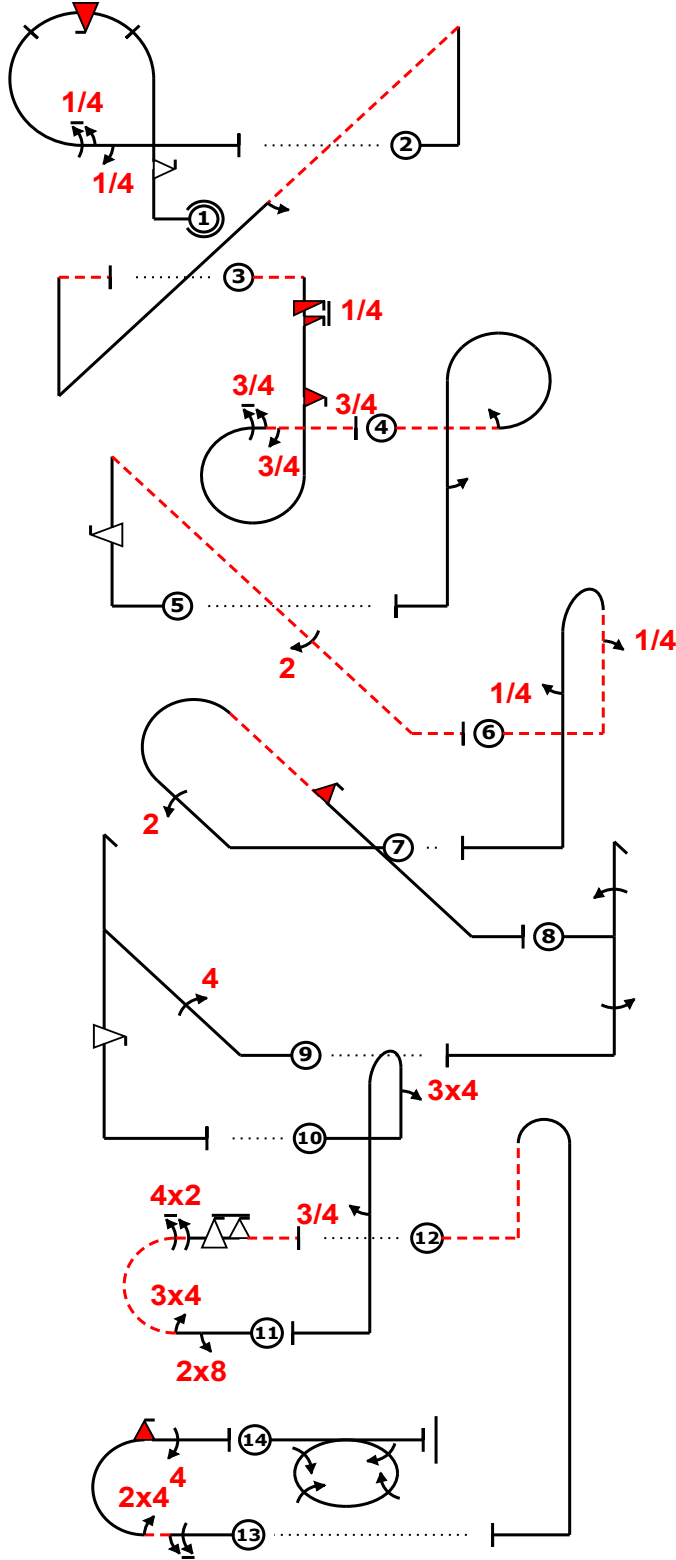

Figure K
441
Total K
481

| | |
|-------------|--------|
| Judges Name | |
| Signature | Number |

| |
|----------|
| Flight # |
|----------|



| Fig | Grade | Pos | Remarks |
|-----|-------|-----|---------|
| 1 | . | | |
| 2 | . | | |
| 3 | . | | |
| 4 | . | | |
| 5 | . | | |
| 6 | . | | |
| 7 | . | | |
| 8 | . | | |
| 9 | . | | |
| 10 | . | | |
| 11 | . | | |
| 12 | . | | |
| 13 | . | | |
| 14 | . | | |

| | |
|-------------|-----------|
| Positioning | 40 |
|-------------|-----------|

| | | | |
|---------------|--|----------------|--|
| Too Low | | Trg Violation | |
| Too High | | Wing Rocks | |
| Interruptions | | Disqual Fig | |
| Insertions | | Other(note...) | |

ed "@A" 4% ``+,2f`rp(if)5,4~ (9,0) "@L" `+n(....'2.....')- (6,0) "@E" -5is.;3ifirp7,3- "@L" -2p' 2..'' (-13,0) "@F" f''k....'',22.- "@L" 3% -,4b`',4.. "@G" (-1,0) 22db.'2if.....' "@H" 1h''1''+++ (-7,0) "@B" ''',44.'dh.'f..+~ (4,0) "@J" ''',34b.'',3.. "@C" 8,34m42;6f- "@L" (6,0) -b.....' (-15,0) "@D" 6,24m2if,44 "@I" 4j4

| Fig 1 A | K | Fig 2 L | K | Fig 3 E | K | Fig 4 L | K | Fig 5 F | K | Fig 6 L | K | Fig 7 G | K | Fig 8 H | K | Fig 9 B | K | Fig 10 J | K | Fig 11 C | K | Fig 12 L | K | Fig 13 D | K | Fig 14 I | K |
|----------|-----------|----------|----------|----------|-----------|---------|----------|---------|-----------|---------|----------|----------|-----------|---------|-----------|---------|-----------|----------|-----------|----------|-----------|----------|----------|----------|-----------|----------|-----------|
| 8.6.1.1 | 11 | 1.3.11.1 | 20 | 8.6.1.4 | 12 | 8.6.7.2 | 12 | 1.2.5.1 | 14 | 8.4.4.2 | 14 | 8.4.14.1 | 12 | 5.2.1.1 | 17 | 5.3.1.1 | 18 | 8.4.1.1 | 13 | 7.2.4.1 | 8 | 8.4.4.2 | 14 | 7.2.2.1 | 6 | 2.4.7.1 | 38 |
| 9.9.1.2 | 15 | 9.1.4.2 | 4 | 9.12.1.5 | 6 | 9.1.3.2 | 4 | 9.9.1.4 | 15 | 9.1.1.1 | 6 | 9.2.2.4 | 11 | 9.1.1.4 | 12 | 9.4.2.4 | 13 | 9.4.1.3 | 12 | 9.8.3.1 | 3 | | | 9.1.3.6 | 10 | | |
| 9.10.8.4 | 15 | | | 9.10.5.3 | 13 | 9.1.5.2 | 4 | 9.2.4.4 | 9 | 9.1.5.1 | 2 | 9.10.4.2 | 13 | 9.1.5.4 | 8 | 9.9.5.4 | 11 | 9.1.5.3 | 6 | 9.4.3.3 | 8 | | | 9.4.3.2 | 5 | | |
| 9.1.3.5 | 9 | | | 9.1.3.7 | 11 | | | | | | | | | | | | | | | 9.2.3.8 | 15 | | | 9.10.8.2 | 15 | | |
| 9.1.3.1 | 2 | | | 9.1.3.3 | 6 | | | | | | | | | | | | | | | 9.9.3.6 | 14 | | | 9.4.3.4 | 11 | | |
| | 52 | | 6 | | 48 | | 6 | | 38 | | 6 | | 36 | | 37 | | 42 | | 31 | | 48 | | 6 | | 47 | | 38 |

Pilot: **PROPOSAL F**

A/C:

Team: **HUN**

PROPOSAL F



CIVA Unlimited SEP 23
 Programme4 EAC 23 PAVULLO, ITA

Figure K
441
 Total K
481

| | | |
|-------------|--------|----------|
| Judges Name | | Flight # |
| Signature | Number | |

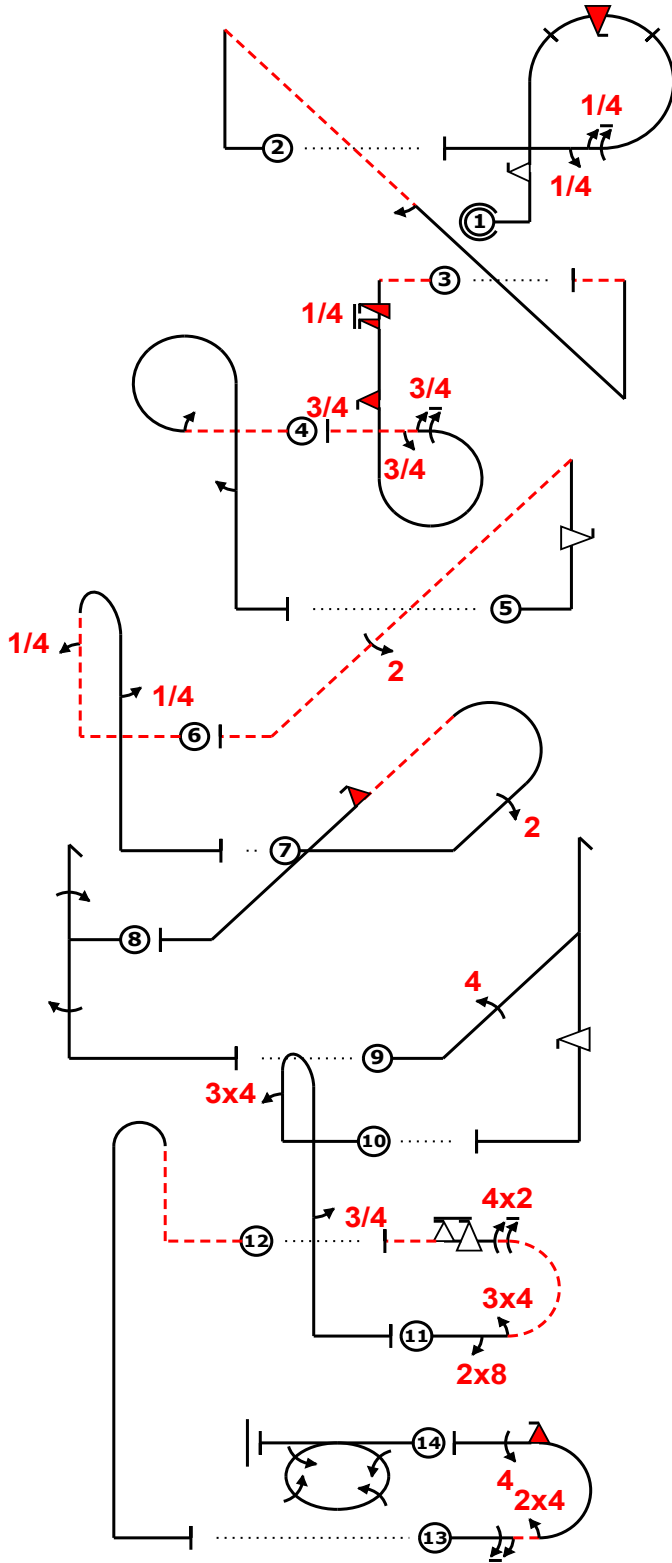
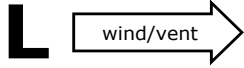

| Fig | Grade | Pos | Remarks |
|-----|-------|-----|---------|
| 1 | . | | |
| 2 | . | | |
| 3 | . | | |
| 4 | . | | |
| 5 | . | | |
| 6 | . | | |
| 7 | . | | |
| 8 | . | | |
| 9 | . | | |
| 10 | . | | |
| 11 | . | | |
| 12 | . | | |
| 13 | . | | |
| 14 | . | | |

Positioning **40**

| | | | |
|---------------|--|----------------|--|
| Too Low | | Trg Violation | |
| Too High | | Wing Rocks | |
| Interruptions | | Disqual Fig | |
| Insertions | | Other(note...) | |

ed "@A" 4% `'+,2f`rp(if)5,4~ (9,0) "@L" `+n(....'2.....')- (6,0) "@E" -5is.;3ifirp7,3- "@L" -2p' 2..'' (-13,0) "@F" f''k....'',22.- "@L" 3% -,4b`',4.. "@G" (-1,0) 22db.'2if.....' "@H" 1h''1''+++ (-7,0) "@B" ''',44.'dh.'f..+~ (4,0) "@J" ''',34b.'',3.. "@C" 8,34m42;6f- "@L" (6,0) -b.....' (-15,0) "@D" 6,24m2if,44 "@I" 4j4

| Fig 1 A | K | Fig 2 L | K | Fig 3 E | K | Fig 4 L | K | Fig 5 F | K | Fig 6 L | K | Fig 7 G | K | Fig 8 H | K | Fig 9 B | K | Fig 10 J | K | Fig 11 C | K | Fig 12 L | K | Fig 13 D | K | Fig 14 I | K |
|----------|-----------|----------|----------|----------|-----------|---------|----------|---------|-----------|---------|----------|----------|-----------|---------|-----------|---------|-----------|----------|-----------|----------|-----------|----------|----------|----------|-----------|----------|-----------|
| 8.6.1.1 | 11 | 1.3.11.1 | 20 | 8.6.1.4 | 12 | 8.6.7.2 | 12 | 1.2.5.1 | 14 | 8.4.4.2 | 14 | 8.4.14.1 | 12 | 5.2.1.1 | 17 | 5.3.1.1 | 18 | 8.4.1.1 | 13 | 7.2.4.1 | 8 | 8.4.4.2 | 14 | 7.2.2.1 | 6 | 2.4.7.1 | 38 |
| 9.9.1.2 | 15 | 9.1.4.2 | 4 | 9.12.1.5 | 6 | 9.1.3.2 | 4 | 9.9.1.4 | 15 | 9.1.1.1 | 6 | 9.2.2.4 | 11 | 9.1.1.4 | 12 | 9.4.2.4 | 13 | 9.4.1.3 | 12 | 9.8.3.1 | 3 | | | 9.1.3.6 | 10 | | |
| 9.10.8.4 | 15 | | | 9.10.5.3 | 13 | 9.1.5.2 | 4 | 9.2.4.4 | 9 | 9.1.5.1 | 2 | 9.10.4.2 | 13 | 9.1.5.4 | 8 | 9.9.5.4 | 11 | 9.1.5.3 | 6 | 9.4.3.3 | 8 | | | 9.4.3.2 | 5 | | |
| 9.1.3.5 | 9 | | | 9.1.3.7 | 11 | | | | | | | | | | | | | | | 9.2.3.8 | 15 | | | 9.10.8.2 | 15 | | |
| 9.1.3.1 | 2 | | | 9.1.3.3 | 6 | | | | | | | | | | | | | | | 9.9.3.6 | 14 | | | 9.4.3.4 | 11 | | |
| | 52 | | 6 | | 48 | | 6 | | 38 | | 6 | | 36 | | 37 | | 42 | | 31 | | 48 | | 6 | | 47 | | 38 |

Pilot: **PROPOSAL F**

A/C:

Team: **HUN**

PROPOSAL G



CIVA Unlimited SEP 23
 Programme4 EAC 23 PAVULLO, ITA

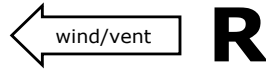
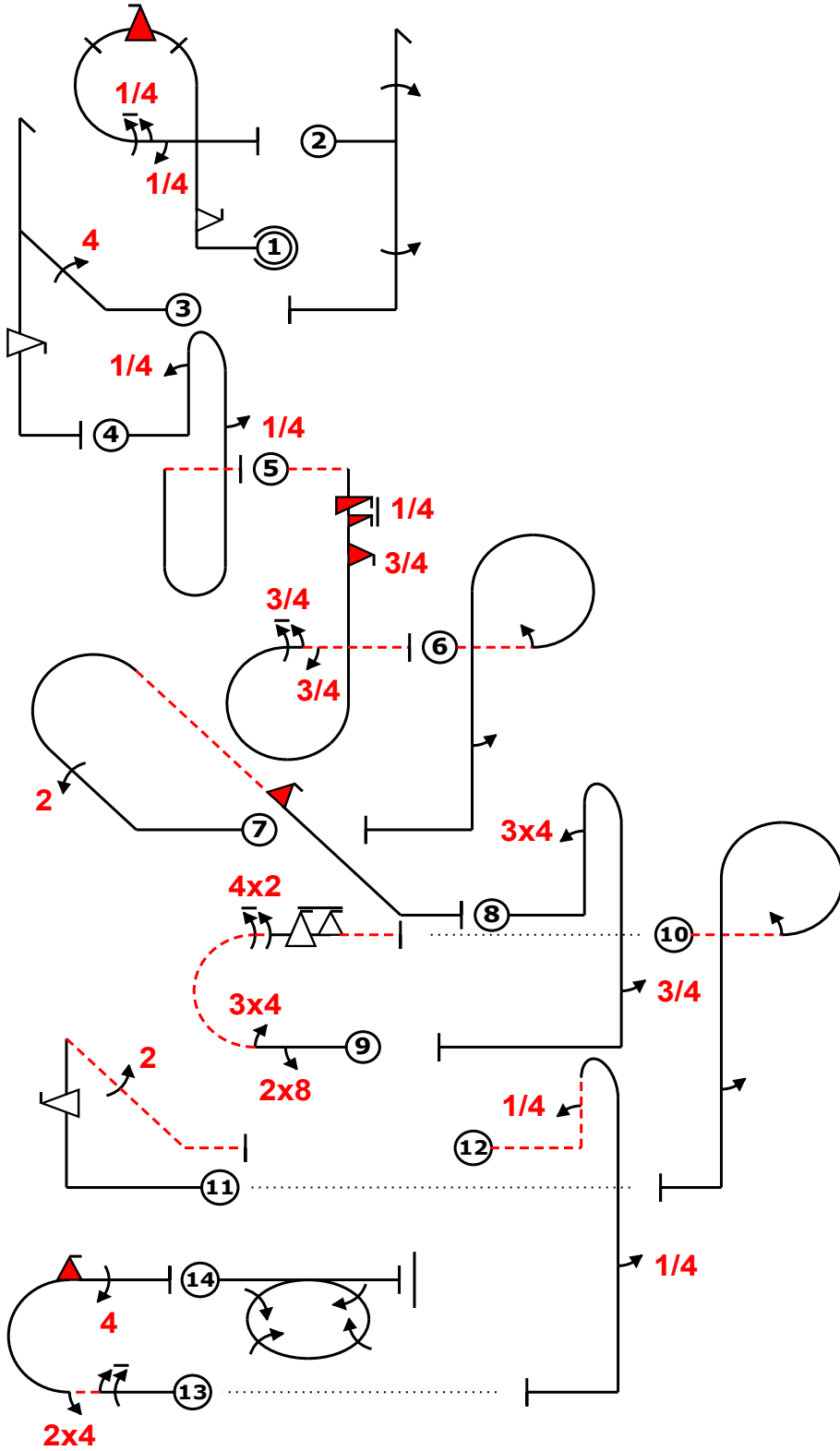

Figure K
441
 Total K
481

| | |
|-------------|--------|
| Judges Name | |
| Signature | Number |

Flight #



| Fig | Grade | Pos | Remarks |
|-----|-------|-----|---------|
| 1 | . | | |
| 2 | . | | |
| 3 | . | | |
| 4 | . | | |
| 5 | . | | |
| 6 | . | | |
| 7 | . | | |
| 8 | . | | |
| 9 | . | | |
| 10 | . | | |
| 11 | . | | |
| 12 | . | | |
| 13 | . | | |
| 14 | . | | |

Positioning **40**

| | | | |
|---------------|--|----------------|--|
| Too Low | | Trg Violation | |
| Too High | | Wing Rocks | |
| Interruptions | | Disqual Fig | |
| Insertions | | Other(note...) | |

ed "@A" ,2f.rp(,if)5,4 "@H" 2> ,1h.'1'+ "@B" 5> ,44dh.'f.' "@L" /'+4bb(''4..)'-> "@E" -5is;3
 if.'irp7,3- "@L" -''2p.2.'+ "@G" 5> '''+22db..'2if... "@J" '+34b..3++ "@C" 3> 8,34m42;6f- (14,0)
 "@L" -''2p..'2.' (-25,0) "@F" ~+fk''22''- "@L" 13> -''4b..4.' (-18,0) "@D" ,6,24m2if,44 "@I"
 4j4

| Fig 1 A | K | Fig 2 H | K | Fig 3 B | K | Fig 4 L | K | Fig 5 E | K | Fig 6 L | K | Fig 7 G | K | Fig 8 J | K | Fig 9 C | K | Fig 10 L | K | Fig 11 F | K | Fig 12 L | K | Fig 13 D | K | Fig 14 I | K |
|----------|-----------|---------|-----------|---------|-----------|---------|----------|----------|-----------|---------|----------|----------|-----------|---------|-----------|---------|-----------|----------|----------|----------|-----------|----------|----------|----------|-----------|----------|-----------|
| 8.6.1.1 | 11 | 5.2.1.1 | 17 | 5.3.1.1 | 18 | 8.8.1.1 | 18 | 8.6.1.4 | 12 | 8.6.7.2 | 12 | 8.4.14.1 | 12 | 8.4.1.1 | 13 | 7.2.4.1 | 8 | 8.6.7.2 | 12 | 1.2.5.1 | 14 | 8.4.4.2 | 14 | 7.2.2.1 | 6 | 2.4.7.1 | 38 |
| 9.9.1.2 | 15 | 9.1.1.4 | 12 | 9.4.2.4 | 13 | 9.1.1.1 | 6 | 9.12.1.5 | 6 | 9.1.3.2 | 4 | 9.2.2.4 | 11 | 9.4.1.3 | 12 | 9.8.3.1 | 3 | 9.1.3.2 | 4 | 9.9.1.4 | 15 | 9.1.1.1 | 6 | 9.1.3.6 | 10 | | |
| 9.10.8.4 | 15 | 9.1.5.4 | 8 | 9.9.5.4 | 11 | 9.1.5.1 | 2 | 9.10.5.3 | 13 | 9.1.5.2 | 4 | 9.10.4.2 | 13 | 9.1.5.3 | 6 | 9.4.3.3 | 8 | 9.1.5.2 | 4 | 9.2.4.4 | 9 | 9.1.5.1 | 2 | 9.4.3.2 | 5 | | |
| 9.1.3.5 | 9 | | | | | | | 9.1.3.7 | 11 | | | | | | | 9.2.3.8 | 15 | | | | | | | 9.10.8.2 | 15 | | |
| 9.1.3.1 | 2 | | | | | | | 9.1.3.3 | 6 | | | | | | | 9.9.3.6 | 14 | | | | | | | 9.4.3.4 | 11 | | |
| | 52 | | 37 | | 42 | | 6 | | 48 | | 6 | | 36 | | 31 | | 48 | | 6 | | 38 | | 6 | | 47 | | 38 |

Pilot: PROPSAL G

A/C: Over the clouds F-HIST Team: LUX

PROPOSAL G



CIVA Unlimited SEP 23
 Programme4 EAC 23 PAVULLO, ITA

Figure K
441
 Total K
481

| | | |
|-------------|--------|----------|
| Judges Name | | Flight # |
| Signature | Number | |

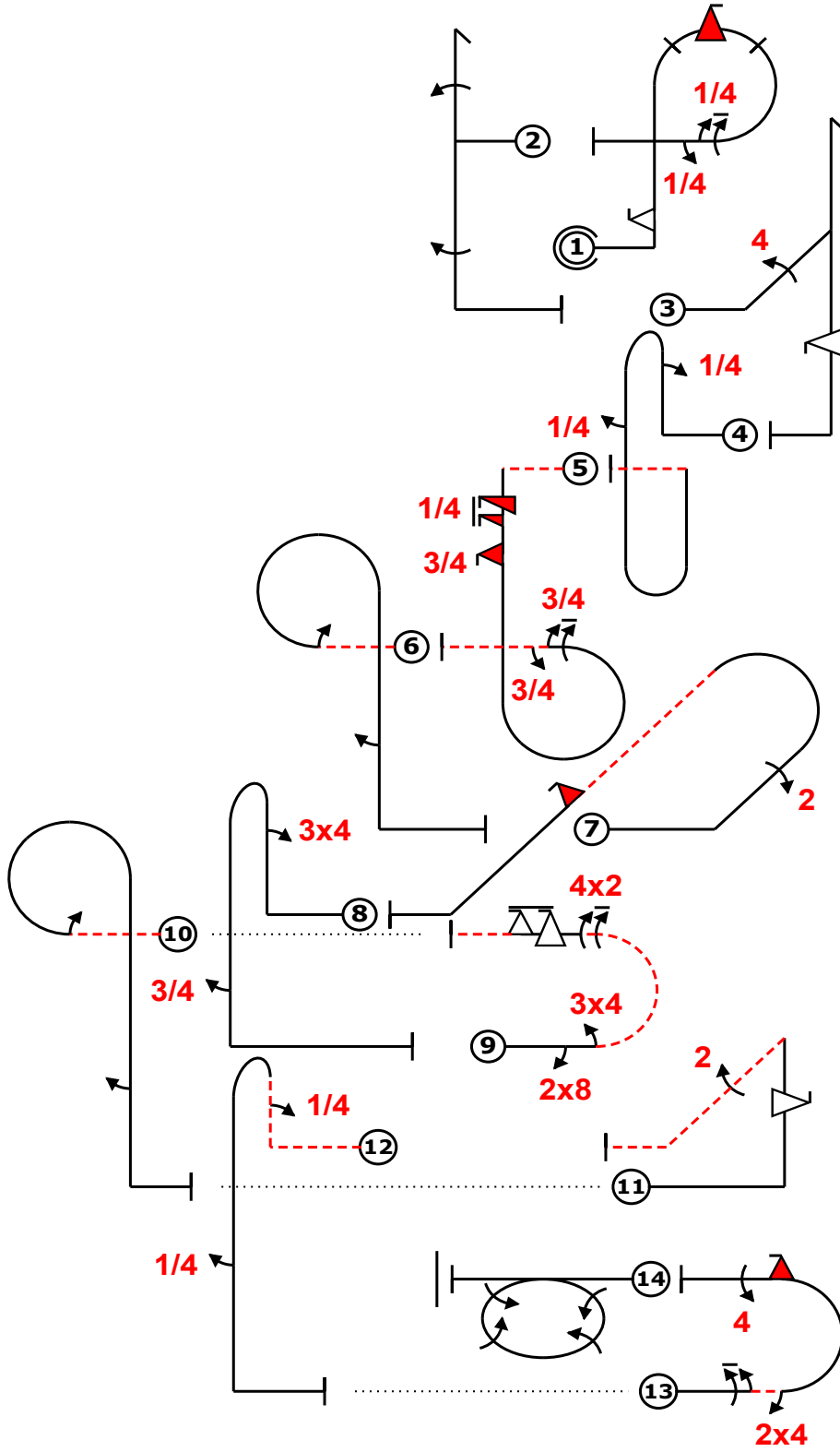
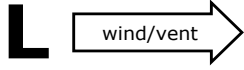

| Fig | Grade | Pos | Remarks |
|-----|-------|-----|---------|
| 1 | . | | |
| 2 | . | | |
| 3 | . | | |
| 4 | . | | |
| 5 | . | | |
| 6 | . | | |
| 7 | . | | |
| 8 | . | | |
| 9 | . | | |
| 10 | . | | |
| 11 | . | | |
| 12 | . | | |
| 13 | . | | |
| 14 | . | | |

Positioning
40

| | | | |
|---------------|--|----------------|--|
| Too Low | | Trg Violation | |
| Too High | | Wing Rocks | |
| Interruptions | | Disqual Fig | |
| Insertions | | Other(note...) | |

ed "@A" ,2f.rp(,if)5,4 "@H" 2> ,1h.'1'+ "@B" 5> ,44dh.'f.' "@L" /'+4bb(''4..)'-> "@E" -5is;3
 if.'irp7,3- "@L" -''2p.2.'+ "@G" 5> ''''+22db..'2if... "@J" ^'+34b..3++ "@C" 3> 8,34m42;6f- (14,0)
 "@L" -''2p..'2.' (-25,0) "@F" ~+fk''22''- "@L" 13> -''4b..4.' (-18,0) "@D" ,6,24m2if,44 "@I"
 4j4

| Fig 1 A | K | Fig 2 H | K | Fig 3 B | K | Fig 4 L | K | Fig 5 E | K | Fig 6 L | K | Fig 7 G | K | Fig 8 J | K | Fig 9 C | K | Fig 10 L | K | Fig 11 F | K | Fig 12 L | K | Fig 13 D | K | Fig 14 I | K |
|----------|-----------|---------|-----------|---------|-----------|---------|----------|----------|-----------|---------|----------|----------|-----------|---------|-----------|---------|-----------|----------|----------|----------|-----------|----------|----------|----------|-----------|----------|-----------|
| 8.6.1.1 | 11 | 5.2.1.1 | 17 | 5.3.1.1 | 18 | 8.8.1.1 | 18 | 8.6.1.4 | 12 | 8.6.7.2 | 12 | 8.4.14.1 | 12 | 8.4.1.1 | 13 | 7.2.4.1 | 8 | 8.6.7.2 | 12 | 1.2.5.1 | 14 | 8.4.4.2 | 14 | 7.2.2.1 | 6 | 2.4.7.1 | 38 |
| 9.9.1.2 | 15 | 9.1.1.4 | 12 | 9.4.2.4 | 13 | 9.1.1.1 | 6 | 9.12.1.5 | 6 | 9.1.3.2 | 4 | 9.2.2.4 | 11 | 9.4.1.3 | 12 | 9.8.3.1 | 3 | 9.1.3.2 | 4 | 9.9.1.4 | 15 | 9.1.1.1 | 6 | 9.1.3.6 | 10 | | |
| 9.10.8.4 | 15 | 9.1.5.4 | 8 | 9.9.5.4 | 11 | 9.1.5.1 | 2 | 9.10.5.3 | 13 | 9.1.5.2 | 4 | 9.10.4.2 | 13 | 9.1.5.3 | 6 | 9.4.3.3 | 8 | 9.1.5.2 | 4 | 9.2.4.4 | 9 | 9.1.5.1 | 2 | 9.4.3.2 | 5 | | |
| 9.1.3.5 | 9 | | | | | | | 9.1.3.7 | 11 | | | | | | | 9.2.3.8 | 15 | | | | | | | 9.10.8.2 | 15 | | |
| 9.1.3.1 | 2 | | | | | | | 9.1.3.3 | 6 | | | | | | | 9.9.3.6 | 14 | | | | | | | 9.4.3.4 | 11 | | |
| | 52 | | 37 | | 42 | | 6 | | 48 | | 6 | | 36 | | 31 | | 48 | | 6 | | 38 | | 6 | | 47 | | 38 |

Pilot: PROPSAL G

A/C: Over the clouds F-HIST Team: LUX

PROPOSAL H



| | | |
|------------|---------------------|--------|
| CIVA | Unlimited | SEP 23 |
| Programme4 | EAC 23 PAVULLO, ITA | |

Figure K
441
Total K
481

| | | |
|-------------|--------|----------|
| Judges Name | | Flight # |
| Signature | Number | |

← wind/vent **R**

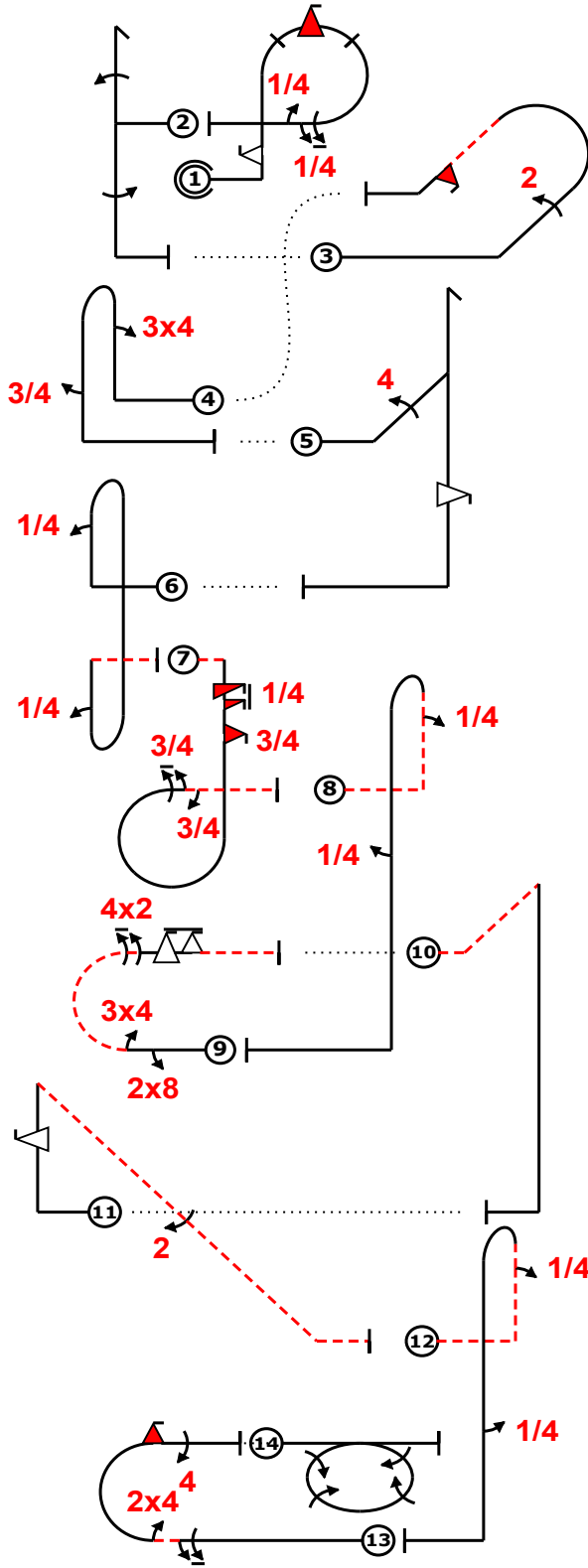

| Fig | Grade | Pos | Remarks |
|-----|-------|-----|---------|
| 1 | . | | |
| 2 | . | | |
| 3 | . | | |
| 4 | . | | |
| 5 | . | | |
| 6 | . | | |
| 7 | . | | |
| 8 | . | | |
| 9 | . | | |
| 10 | . | | |
| 11 | . | | |
| 12 | . | | |
| 13 | . | | |
| 14 | . | | |

Positioning **40**

| | | | |
|---------------|--|----------------|--|
| Too Low | | Trg Violation | |
| Too High | | Wing Rocks | |
| Interruptions | | Disqual Fig | |
| Insertions | | Other(note...) | |

"@A" 2frp(if)5,4 "@H" 1h'1. (8,0) "@G" 22db2if (-8,17) "@J" ,34b,3+- (3,0) "@B" 44dh().f.''+~ (-6,0) "@L" ^+4bb(.)4- "@E" ^-5is;3if'irp7,3- 2> "@L" -,4b...4...+~ "@C" 8,34m42;6f-~ (7,0) "@L" ^-t.....' (-25,0) "@F" fk...'22... (0,0) "@L" -,4b...'4...' "@D" ...6,24m2if,44 (-2,0) "@I" 4 j4 eu eu eu eu eu eu eu

| Fig 1 A | K | Fig 2 H | K | Fig 3 G | K | Fig 4 J | K | Fig 5 B | K | Fig 6 L | K | Fig 7 E | K | Fig 8 L | K | Fig 9 C | K | Fig 10 L | K | Fig 11 F | K | Fig 12 L | K | Fig 13 D | K | Fig 14 I | K |
|----------|-----------|---------|-----------|----------|-----------|---------|-----------|---------|-----------|---------|----------|----------|-----------|---------|----------|---------|-----------|----------|----------|----------|-----------|----------|----------|----------|-----------|----------|-----------|
| 8.6.1.1 | 11 | 5.2.1.1 | 17 | 8.4.14.1 | 12 | 8.4.1.1 | 13 | 5.3.1.1 | 18 | 8.8.1.1 | 18 | 8.6.1.4 | 12 | 8.4.4.2 | 14 | 7.2.4.1 | 8 | 1.2.2.2 | 13 | 1.2.5.1 | 14 | 8.4.4.2 | 14 | 7.2.2.1 | 6 | 2.4.7.1 | 38 |
| 9.9.1.2 | 15 | 9.1.1.4 | 12 | 9.2.2.4 | 11 | 9.4.1.3 | 12 | 9.4.2.4 | 13 | 9.1.1.1 | 6 | 9.12.1.5 | 6 | 9.1.1.1 | 6 | 9.8.3.1 | 3 | | | 9.9.1.4 | 15 | 9.1.1.1 | 6 | 9.1.3.6 | 10 | | |
| 9.10.8.4 | 15 | 9.1.5.4 | 8 | 9.10.4.2 | 13 | 9.1.5.3 | 6 | 9.9.5.4 | 11 | 9.1.1.1 | 6 | 9.10.5.3 | 13 | 9.1.5.1 | 2 | 9.4.3.3 | 8 | | | 9.2.4.4 | 9 | 9.1.5.1 | 2 | 9.4.3.2 | 5 | | |
| 9.1.3.5 | 9 | | | | | | | | | | | 9.1.3.7 | 11 | | | 9.2.3.8 | 15 | | | | | | | 9.10.8.2 | 15 | | |
| 9.1.3.1 | 2 | | | | | | | | | | | 9.1.3.3 | 6 | | | 9.9.3.6 | 14 | | | | | | | 9.4.3.4 | 11 | | |
| | 52 | | 37 | | 36 | | 31 | | 42 | | 6 | | 48 | | 6 | | 48 | | 6 | | 38 | | 6 | | 47 | | 38 |

Pilot: **PROPOSAL H**

A/C:

Team: **POL**

PROPOSAL H



CIVA Unlimited SEP 23
 Programme4 EAC 23 PAVULLO, ITA

Figure K
441
 Total K
481

| | | |
|-------------|--------|----------|
| Judges Name | | Flight # |
| Signature | Number | |

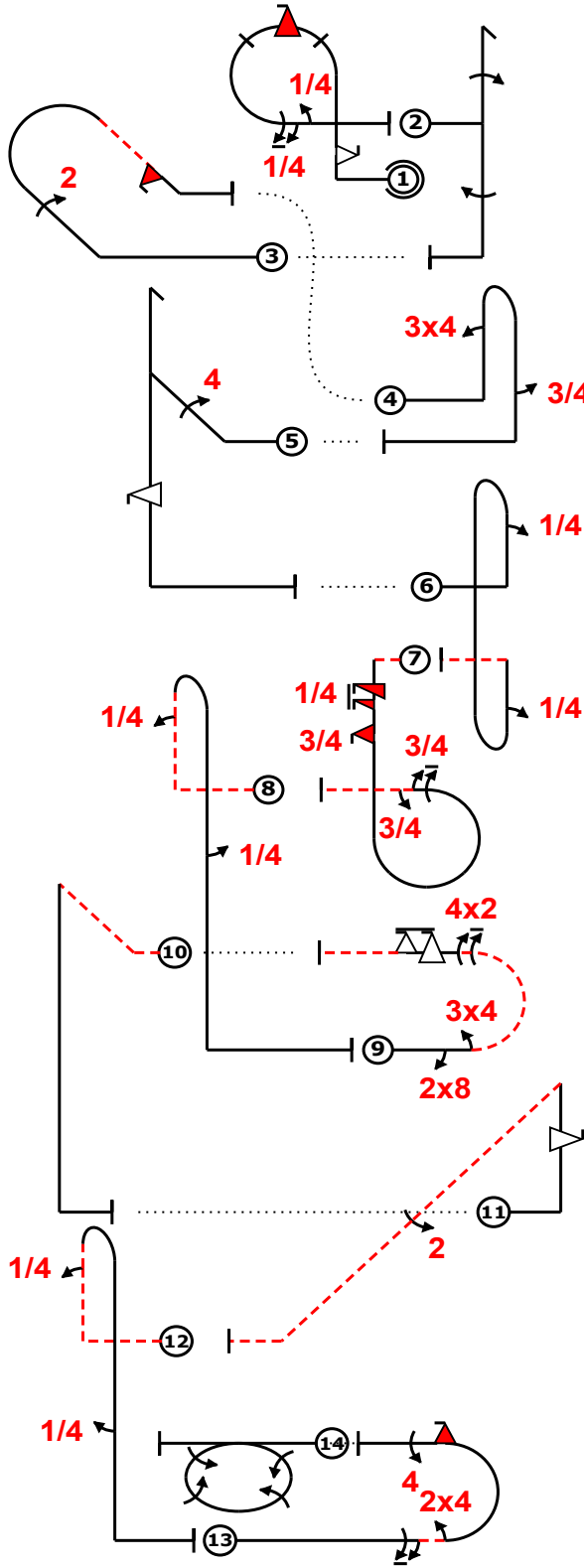
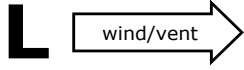

| Fig | Grade | Pos | Remarks |
|-----|-------|-----|---------|
| 1 | . | | |
| 2 | . | | |
| 3 | . | | |
| 4 | . | | |
| 5 | . | | |
| 6 | . | | |
| 7 | . | | |
| 8 | . | | |
| 9 | . | | |
| 10 | . | | |
| 11 | . | | |
| 12 | . | | |
| 13 | . | | |
| 14 | . | | |

Positioning
40

| | | | |
|---------------|--|----------------|--|
| Too Low | | Trg Violation | |
| Too High | | Wing Rocks | |
| Interruptions | | Disqual Fig | |
| Insertions | | Other(note...) | |

"@A" 2frp(if)5,4 "@H" 1h"1. (8,0) "@G" 22db2if (-8,17) "@J" ,34b,3+- (3,0) "@B" 44dh().f.''+~ (-6,0) "@L" ^+4bb(.)4- "@E" ^-5is;3if"irp7,3- 2> "@L" -,4b...,4...+~ "@C" 8,34m42;6f-~ (7,0) "@L" ^-t.....' (-25,0) "@F" fk...'22... (0,0) "@L" -,4b...'4.' "@D" ...6,24m2if,44 (-2,0) "@I" 4 j4 eu eu eu eu eu eu eu

| Fig 1 A | K | Fig 2 H | K | Fig 3 G | K | Fig 4 J | K | Fig 5 B | K | Fig 6 L | K | Fig 7 E | K | Fig 8 L | K | Fig 9 C | K | Fig 10 L | K | Fig 11 F | K | Fig 12 L | K | Fig 13 D | K | Fig 14 I | K |
|----------|-----------|---------|-----------|----------|-----------|---------|-----------|---------|-----------|---------|----------|----------|-----------|---------|----------|---------|-----------|----------|----------|----------|-----------|----------|----------|----------|-----------|----------|-----------|
| 8.6.1.1 | 11 | 5.2.1.1 | 17 | 8.4.14.1 | 12 | 8.4.1.1 | 13 | 5.3.1.1 | 18 | 8.8.1.1 | 18 | 8.6.1.4 | 12 | 8.4.4.2 | 14 | 7.2.4.1 | 8 | 1.2.2.2 | 13 | 1.2.5.1 | 14 | 8.4.4.2 | 14 | 7.2.2.1 | 6 | 2.4.7.1 | 38 |
| 9.9.1.2 | 15 | 9.1.1.4 | 12 | 9.2.2.4 | 11 | 9.4.1.3 | 12 | 9.4.2.4 | 13 | 9.1.1.1 | 6 | 9.12.1.5 | 6 | 9.1.1.1 | 6 | 9.8.3.1 | 3 | | | 9.9.1.4 | 15 | 9.1.1.1 | 6 | 9.1.3.6 | 10 | | |
| 9.10.8.4 | 15 | 9.1.5.4 | 8 | 9.10.4.2 | 13 | 9.1.5.3 | 6 | 9.9.5.4 | 11 | 9.1.1.1 | 6 | 9.10.5.3 | 13 | 9.1.5.1 | 2 | 9.4.3.3 | 8 | | | 9.2.4.4 | 9 | 9.1.5.1 | 2 | 9.4.3.2 | 5 | | |
| 9.1.3.5 | 9 | | | | | | | | | | | 9.1.3.7 | 11 | | | 9.2.3.8 | 15 | | | | | | | 9.10.8.2 | 15 | | |
| 9.1.3.1 | 2 | | | | | | | | | | | 9.1.3.3 | 6 | | | 9.9.3.6 | 14 | | | | | | | 9.4.3.4 | 11 | | |
| | 52 | | 37 | | 36 | | 31 | | 42 | | 6 | | 48 | | 6 | | 48 | | 6 | | 38 | | 6 | | 47 | | 38 |

Pilot: **PROPOSAL H**

A/C:

Team: **POL**

PROPOSAL I



| | | |
|------------|---------------------|--------|
| CIVA | Unlimited | SEP 23 |
| Programme4 | EAC 23 PAVULLO, ITA | |

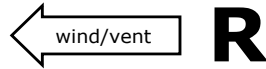
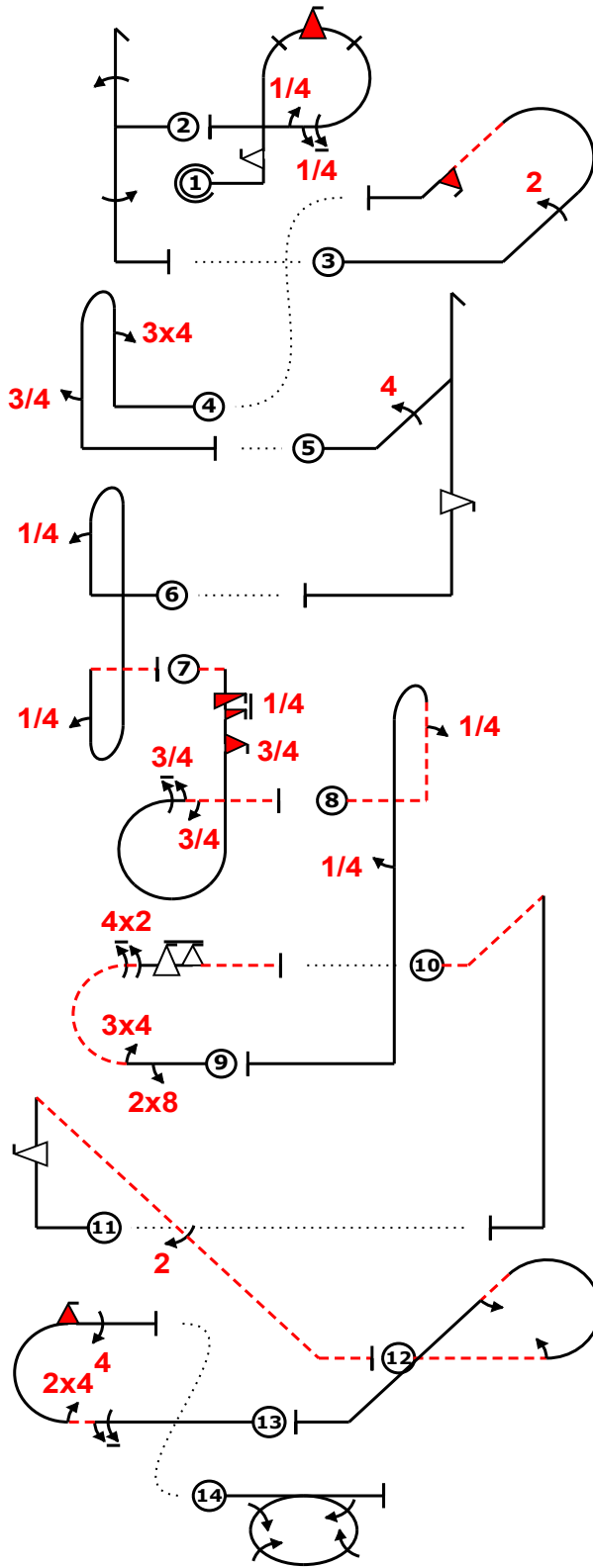

Figure K
441
Total K
481

| | | |
|-------------|--------|----------|
| Judges Name | | Flight # |
| Signature | Number | |



| Fig | Grade | Pos | Remarks |
|-----|-------|-----|---------|
| 1 | . | | |
| 2 | . | | |
| 3 | . | | |
| 4 | . | | |
| 5 | . | | |
| 6 | . | | |
| 7 | . | | |
| 8 | . | | |
| 9 | . | | |
| 10 | . | | |
| 11 | . | | |
| 12 | . | | |
| 13 | . | | |
| 14 | . | | |

Positioning
40

| | | | |
|---------------|--|----------------|--|
| Too Low | | Trg Violation | |
| Too High | | Wing Rocks | |
| Interruptions | | Disqual Fig | |
| Insertions | | Other(note...) | |

"@A" 2frp(if)5,4 "@H" 1h"1. (8,0) "@G" 22db2if (-8,17) "@J" ,34b,3+- (3,0) "@B" 44dh().f.''+~ (~-6,0) "@L" ^+4bb(.)4- "@E" ^-5is;3if"irp7,3- 2> "@L" ^-,4b.,,4....+~ "@C" 8,34m42;6f~ (7,0) "@L" ^-t.....' (-25,0) "@F" fk.'',22... "@L" ^-""2c2.' ..'6,24m2if,44 (0,14) "@I" 4j4 eu eu eu eu eu eu eu

| Fig 1 A | K | Fig 2 H | K | Fig 3 G | K | Fig 4 J | K | Fig 5 B | K | Fig 6 L | K | Fig 7 E | K | Fig 8 L | K | Fig 9 C | K | Fig 10 L | K | Fig 11 F | K | Fig 12 L | K | Fig 13 | K | Fig 14 I | K |
|----------|-----------|---------|-----------|----------|-----------|---------|-----------|---------|-----------|---------|----------|----------|-----------|---------|----------|---------|-----------|----------|----------|----------|-----------|----------|----------|----------|-----------|----------|-----------|
| 8.6.1.1 | 11 | 5.2.1.1 | 17 | 8.4.14.1 | 12 | 8.4.1.1 | 13 | 5.3.1.1 | 18 | 8.8.1.1 | 18 | 8.6.1.4 | 12 | 8.4.4.2 | 14 | 7.2.4.1 | 8 | 1.2.2.2 | 13 | 1.2.5.1 | 14 | 8.5.8.2 | 11 | 7.2.2.1 | 6 | 2.4.7.1 | 38 |
| 9.9.1.2 | 15 | 9.1.1.4 | 12 | 9.2.2.4 | 11 | 9.4.1.3 | 12 | 9.4.2.4 | 13 | 9.1.1.1 | 6 | 9.12.1.5 | 6 | 9.1.1.1 | 6 | 9.8.3.1 | 3 | | | 9.9.1.4 | 15 | 9.1.3.2 | 4 | 9.1.3.6 | 10 | | |
| 9.10.8.4 | 15 | 9.1.5.4 | 8 | 9.10.4.2 | 13 | 9.1.5.3 | 6 | 9.9.5.4 | 11 | 9.1.1.1 | 6 | 9.10.5.3 | 13 | 9.1.5.1 | 2 | 9.4.3.3 | 8 | | | 9.2.4.4 | 9 | 9.1.4.2 | 4 | 9.4.3.2 | 5 | | |
| 9.1.3.5 | 9 | | | | | | | | | | | 9.1.3.7 | 11 | | | 9.2.3.8 | 15 | | | | | | | 9.10.8.2 | 15 | | |
| 9.1.3.1 | 2 | | | | | | | | | | | 9.1.3.3 | 6 | | | 9.9.3.6 | 14 | | | | | | | 9.4.3.4 | 11 | | |
| | 52 | | 37 | | 36 | | 31 | | 42 | | 6 | | 48 | | 6 | | 48 | | 6 | | 38 | | 6 | | 47 | | 38 |

Pilot: **PROPOSAL I**

A/C:

Team: **POL**

PROPOSAL I



CIVA Unlimited SEP 23
 Programme4 EAC 23 PAVULLO, ITA

Figure K
441
 Total K
481

| | | |
|-------------|--------|----------|
| Judges Name | | Flight # |
| Signature | Number | |

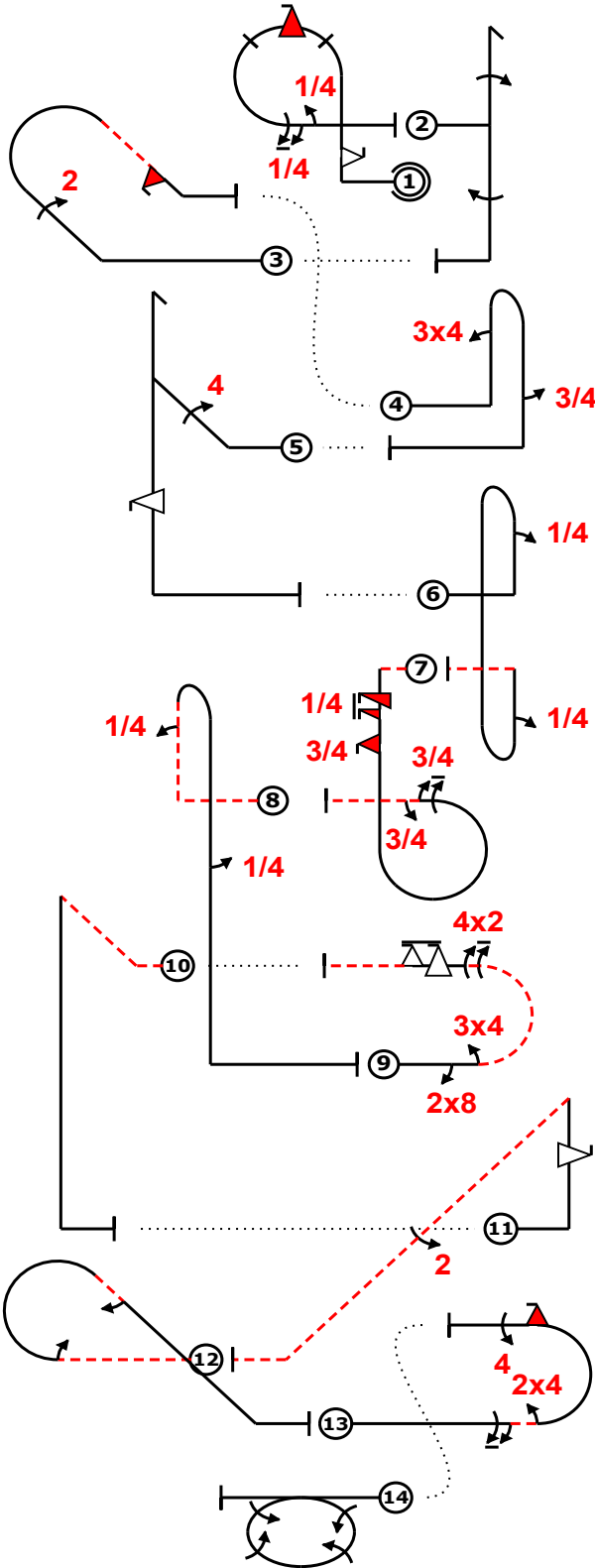
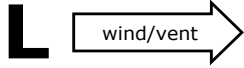

| Fig | Grade | Pos | Remarks |
|-----|-------|-----|---------|
| 1 | . | | |
| 2 | . | | |
| 3 | . | | |
| 4 | . | | |
| 5 | . | | |
| 6 | . | | |
| 7 | . | | |
| 8 | . | | |
| 9 | . | | |
| 10 | . | | |
| 11 | . | | |
| 12 | . | | |
| 13 | . | | |
| 14 | . | | |

Positioning
40

| | | | |
|---------------|--|----------------|--|
| Too Low | | Trg Violation | |
| Too High | | Wing Rocks | |
| Interruptions | | Disqual Fig | |
| Insertions | | Other(note...) | |

"@A" 2frp(if)5,4 "@H" 1h"1. (8,0) "@G" 22db2if (-8,17) "@J" ,34b,3+- (3,0) "@B" 44dh().f.''+- (-6,0) "@L" ^+4bb(.)4- "@E" ^-5is;3if"irp7,3- 2> "@L" ^-,4b.,4.....+~ "@C" 8,34m42;6f~ (7,0) "@L" ^-t.....' (-25,0) "@F" fk...'22... "@L" ^-''2c2.' '...'6,24m2if,44 (0,14) "@I" 4j4 eu eu eu eu eu eu eu eu

| Fig 1 A | K | Fig 2 H | K | Fig 3 G | K | Fig 4 J | K | Fig 5 B | K | Fig 6 L | K | Fig 7 E | K | Fig 8 L | K | Fig 9 C | K | Fig 10 L | K | Fig 11 F | K | Fig 12 L | K | Fig 13 | K | Fig 14 I | K |
|----------|-----------|---------|-----------|----------|-----------|---------|-----------|---------|-----------|---------|----------|----------|-----------|---------|----------|---------|-----------|----------|----------|----------|-----------|----------|----------|----------|-----------|----------|-----------|
| 8.6.1.1 | 11 | 5.2.1.1 | 17 | 8.4.14.1 | 12 | 8.4.1.1 | 13 | 5.3.1.1 | 18 | 8.8.1.1 | 18 | 8.6.1.4 | 12 | 8.4.4.2 | 14 | 7.2.4.1 | 8 | 1.2.2.2 | 13 | 1.2.5.1 | 14 | 8.5.8.2 | 11 | 7.2.2.1 | 6 | 2.4.7.1 | 38 |
| 9.9.1.2 | 15 | 9.1.1.4 | 12 | 9.2.2.4 | 11 | 9.4.1.3 | 12 | 9.4.2.4 | 13 | 9.1.1.1 | 6 | 9.12.1.5 | 6 | 9.1.1.1 | 6 | 9.8.3.1 | 3 | | | 9.9.1.4 | 15 | 9.1.3.2 | 4 | 9.1.3.6 | 10 | | |
| 9.10.8.4 | 15 | 9.1.5.4 | 8 | 9.10.4.2 | 13 | 9.1.5.3 | 6 | 9.9.5.4 | 11 | 9.1.1.1 | 6 | 9.10.5.3 | 13 | 9.15.1 | 2 | 9.4.3.3 | 8 | | | 9.2.4.4 | 9 | 9.1.4.2 | 4 | 9.4.3.2 | 5 | | |
| 9.1.3.5 | 9 | | | | | | | | | | | 9.1.3.7 | 11 | | | 9.2.3.8 | 15 | | | | | | | 9.10.8.2 | 15 | | |
| 9.1.3.1 | 2 | | | | | | | | | | | 9.1.3.3 | 6 | | | 9.9.3.6 | 14 | | | | | | | 9.4.3.4 | 11 | | |
| | 52 | | 37 | | 36 | | 31 | | 42 | | 6 | | 48 | | 6 | | 48 | | 6 | | 38 | | 6 | | 47 | | 38 |

Pilot: **PROPOSAL I**

A/C:

Team: **POL**

PROPOSAL J



| | | |
|------------|---------------------|--------|
| CIVA | Unlimited | SEP 23 |
| Programme4 | EAC 23 PAVULLO, ITA | |

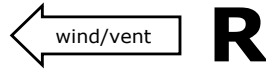
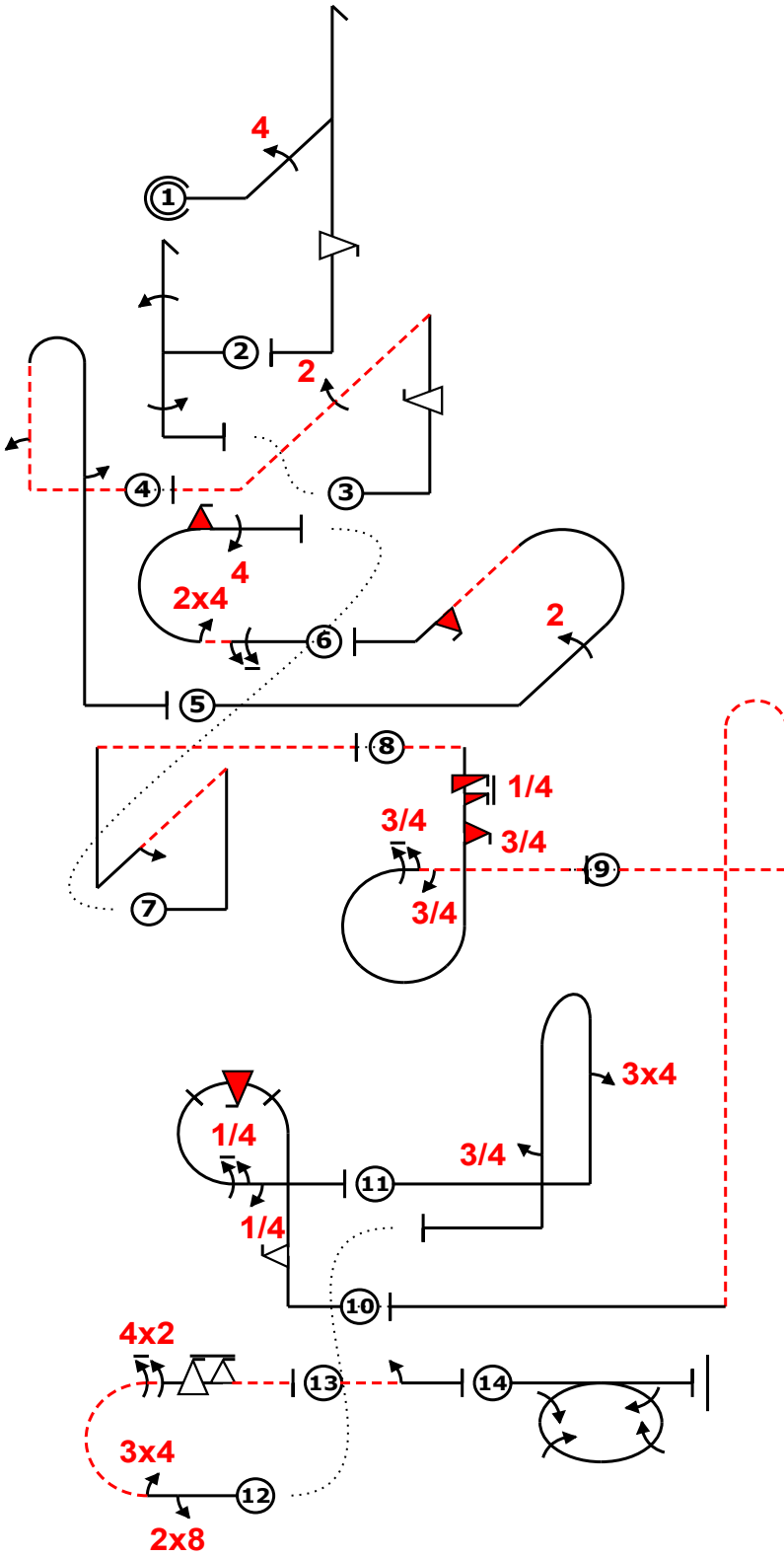

Figure K
441
Total K
481

| | | |
|-------------|--------|----------|
| Judges Name | | Flight # |
| Signature | Number | |



| Fig | Grade | Pos | Remarks |
|-----|-------|-----|---------|
| 1 | . | | |
| 2 | . | | |
| 3 | . | | |
| 4 | . | | |
| 5 | . | | |
| 6 | . | | |
| 7 | . | | |
| 8 | . | | |
| 9 | . | | |
| 10 | . | | |
| 11 | . | | |
| 12 | . | | |
| 13 | . | | |
| 14 | . | | |

Positioning
40

| | | | |
|---------------|--|----------------|--|
| Too Low | | Trg Violation | |
| Too High | | Wing Rocks | |
| Interruptions | | Disqual Fig | |
| Insertions | | Other(note...) | |

"@B" 44dh.'f.' " @H" 1h1 (4,4) "@F" 1% f'k,22- (-2,0) "@L" -1% ~-2.'b.2....' " @G" ~++22db'2if " @D" 6,24m2if,44 (-14,27) "@L" n(2)----- (-2,0) "@E" -5is;3ifirp7,3--- (-3,0) "@L" ~---'pb..... ..'+++++~ (2,0) "@A" -1% '2f.rp(iff)5,4 "@J" 3% ~+,34'b,3 (-7,19) "@C" 8,34m42;6f- "@L" -2 " @I" 4j4

| Fig 1 B | K | Fig 2 H | K | Fig 3 F | K | Fig 4 L | K | Fig 5 G | K | Fig 6 D | K | Fig 7 L | K | Fig 8 E | K | Fig 9 L | K | Fig 10 A | K | Fig 11 J | K | Fig 12 C | K | Fig 13 L | K | Fig 14 I | K |
|---------|-----------|---------|-----------|---------|-----------|----------|----------|----------|-----------|----------|-----------|----------|----------|----------|-----------|---------|----------|----------|-----------|----------|-----------|----------|-----------|----------|----------|----------|-----------|
| 5.3.1.1 | 18 | 5.2.1.1 | 17 | 1.2.5.1 | 14 | 8.4.4.2 | 14 | 8.4.14.1 | 12 | 7.2.2.1 | 6 | 1.3.11.1 | 20 | 8.6.1.4 | 12 | 8.4.2.2 | 17 | 8.6.1.1 | 11 | 8.4.1.1 | 13 | 7.2.4.1 | 8 | 1.1.1.4 | 2 | 2.4.7.1 | 38 |
| 9.4.2.4 | 13 | 9.1.1.4 | 12 | 9.9.1.4 | 15 | 9.1.1.2 | 8 | 9.2.2.4 | 11 | 9.1.3.6 | 10 | 9.1.4.2 | 4 | 9.12.1.5 | 6 | | | 9.9.1.2 | 15 | 9.4.1.3 | 12 | 9.8.3.1 | 3 | 9.1.3.2 | 4 | | |
| 9.9.5.4 | 11 | 9.1.5.4 | 8 | 9.2.4.4 | 9 | 9.1.5.2 | 4 | 9.10.4.2 | 13 | 9.4.3.2 | 5 | | | 9.10.5.3 | 13 | | | 9.10.8.4 | 15 | 9.1.5.3 | 6 | 9.4.3.3 | 8 | | | | |
| | | | | | | 9.10.8.2 | 15 | | | 9.10.8.2 | 15 | | | 9.1.3.7 | 11 | | | 9.1.3.5 | 9 | | | 9.2.3.8 | 15 | | | | |
| | | | | | | 9.4.3.4 | 11 | | | 9.4.3.4 | 11 | | | 9.1.3.3 | 6 | | | 9.1.3.1 | 2 | | | 9.9.3.6 | 14 | | | | |
| | 42 | | 37 | | 38 | | 6 | | 36 | | 47 | | 6 | | 48 | | 6 | | 52 | | 31 | | 48 | | 6 | | 38 |

Pilot: **PROPOSAL J**

A/C:

Team: **SUI**

PROPOSAL J



CIVA Unlimited SEP 23
 Programme4 EAC 23 PAVULLO, ITA

Figure K
441
 Total K
481

| | | |
|-------------|--------|----------|
| Judges Name | | Flight # |
| Signature | Number | |

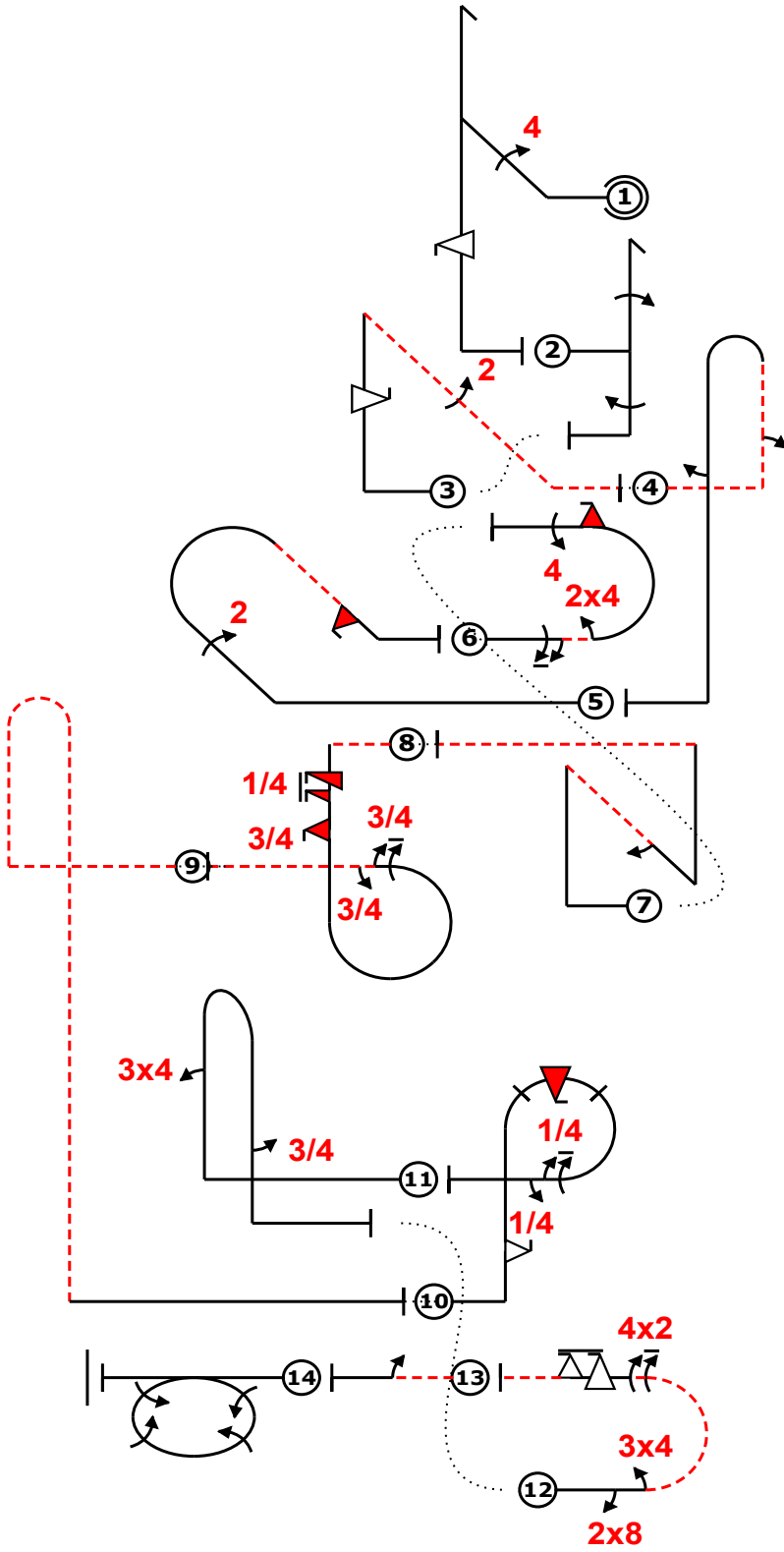
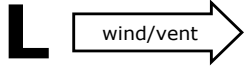

| Fig | Grade | Pos | Remarks |
|-----|-------|-----|---------|
| 1 | . | | |
| 2 | . | | |
| 3 | . | | |
| 4 | . | | |
| 5 | . | | |
| 6 | . | | |
| 7 | . | | |
| 8 | . | | |
| 9 | . | | |
| 10 | . | | |
| 11 | . | | |
| 12 | . | | |
| 13 | . | | |
| 14 | . | | |

Positioning **40**

| | | | |
|---------------|--|----------------|--|
| Too Low | | Trg Violation | |
| Too High | | Wing Rocks | |
| Interruptions | | Disqual Fig | |
| Insertions | | Other(note...) | |

"@B" 44dh.'f.' " @H" 1h1 (4,4) "@F" 1% f'k,22- (2,0) "@L" -1% ~-2.'b.2....' " @G" ~++22db'zif "
 @D" 6,24m2if,44 (-14,27) "@L" n(2)----- (-2,0) "@E" -5is;3ifirp7,3--- (-3,0) "@L" ~---'pb.....
 ..'+++++~ (2,0) "@A" -1% '2f.rp(if)5,4 "@J" 3% ~+,34'b,3 (-7,19) "@C" 8,34m42;6f- "@L" -2 " @I" 4j4

| Fig 1 B | K | Fig 2 H | K | Fig 3 F | K | Fig 4 L | K | Fig 5 G | K | Fig 6 D | K | Fig 7 L | K | Fig 8 E | K | Fig 9 L | K | Fig 10 A | K | Fig 11 J | K | Fig 12 C | K | Fig 13 L | K | Fig 14 I | K |
|---------|-----------|---------|-----------|---------|-----------|---------|----------|----------|-----------|----------|-----------|----------|----------|----------|-----------|---------|----------|----------|-----------|----------|-----------|----------|-----------|----------|----------|----------|-----------|
| 5.3.1.1 | 18 | 5.2.1.1 | 17 | 1.2.5.1 | 14 | 8.4.4.2 | 14 | 8.4.14.1 | 12 | 7.2.2.1 | 6 | 1.3.11.1 | 20 | 8.6.1.4 | 12 | 8.4.2.2 | 17 | 8.6.1.1 | 11 | 8.4.1.1 | 13 | 7.2.4.1 | 8 | 1.1.1.4 | 2 | 2.4.7.1 | 38 |
| 9.4.2.4 | 13 | 9.1.1.4 | 12 | 9.9.1.4 | 15 | 9.1.1.2 | 8 | 9.2.2.4 | 11 | 9.1.3.6 | 10 | 9.1.4.2 | 4 | 9.12.1.5 | 6 | | | 9.9.1.2 | 15 | 9.4.1.3 | 12 | 9.8.3.1 | 3 | 9.1.3.2 | 4 | | |
| 9.9.5.4 | 11 | 9.1.5.4 | 8 | 9.2.4.4 | 9 | 9.1.5.2 | 4 | 9.10.4.2 | 13 | 9.4.3.2 | 5 | | | 9.10.5.3 | 13 | | | 9.10.8.4 | 15 | 9.1.5.3 | 6 | 9.4.3.3 | 8 | | | | |
| | | | | | | | | | | 9.10.8.2 | 15 | | | 9.1.3.7 | 11 | | | 9.1.3.5 | 9 | | | 9.2.3.8 | 15 | | | | |
| | | | | | | | | | | 9.4.3.4 | 11 | | | 9.1.3.3 | 6 | | | 9.1.3.1 | 2 | | | 9.9.3.6 | 14 | | | | |
| | 42 | | 37 | | 38 | | 6 | | 36 | | 47 | | 6 | | 48 | | 6 | | 52 | | 31 | | 48 | | 6 | | 38 |



PAVULLO

CIVA Unlimited Programme4

| | | | | |
|---|--|---|---|--|
| <p>Fig A 8.6.1.1(11) 9.9.1.2(15) 9.10.8.4(15) 9.1.3.5(9) 9.1.3.1(2) K: 52</p> <p>HUN</p> | <p>Fig B 5.3.1.1(18) 9.4.2.4(13) 9.9.5.4(11) K: 42</p> <p>ROU</p> | <p>Fig C 7.2.4.1(8) 9.8.3.1(3) 9.4.3.3(8) 9.2.3.8(15) 9.9.3.6(14) K: 48</p> <p>GER</p> | <p>Fig D 7.2.2.1(6) 9.1.3.6(10) 9.4.3.2(5) 9.10.8.2(15) 9.4.3.4(11) K: 47</p> <p>GRE</p> | <p>Fig E 8.6.1.4(12) 9.12.1.5(6) 9.10.5.3(13) 9.1.3.7(11) 9.1.3.3(6) K: 48</p> <p>POL</p> |
| <p>Fig F 1.2.5.1(14) 9.9.1.4(15) 9.2.4.4(9) K: 38</p> <p>SUI</p> | <p>Fig G 8.4.14.1(12) 9.2.2.4(11) 9.10.4.2(13) K: 36</p> <p>FRA</p> | <p>Fig H 5.2.1.1(17) 9.1.1.4(12) 9.1.5.4(8) K: 37</p> <p>LUX</p> | <p>Fig I 2.4.7.1(38) K: 38</p> <p>CZE</p> | <p>Fig J 8.4.1.1(13) 9.4.1.3(12) 9.1.5.3(6) K: 31</p> <p>ITA</p> |