

wind/vent ← **R**

**A**

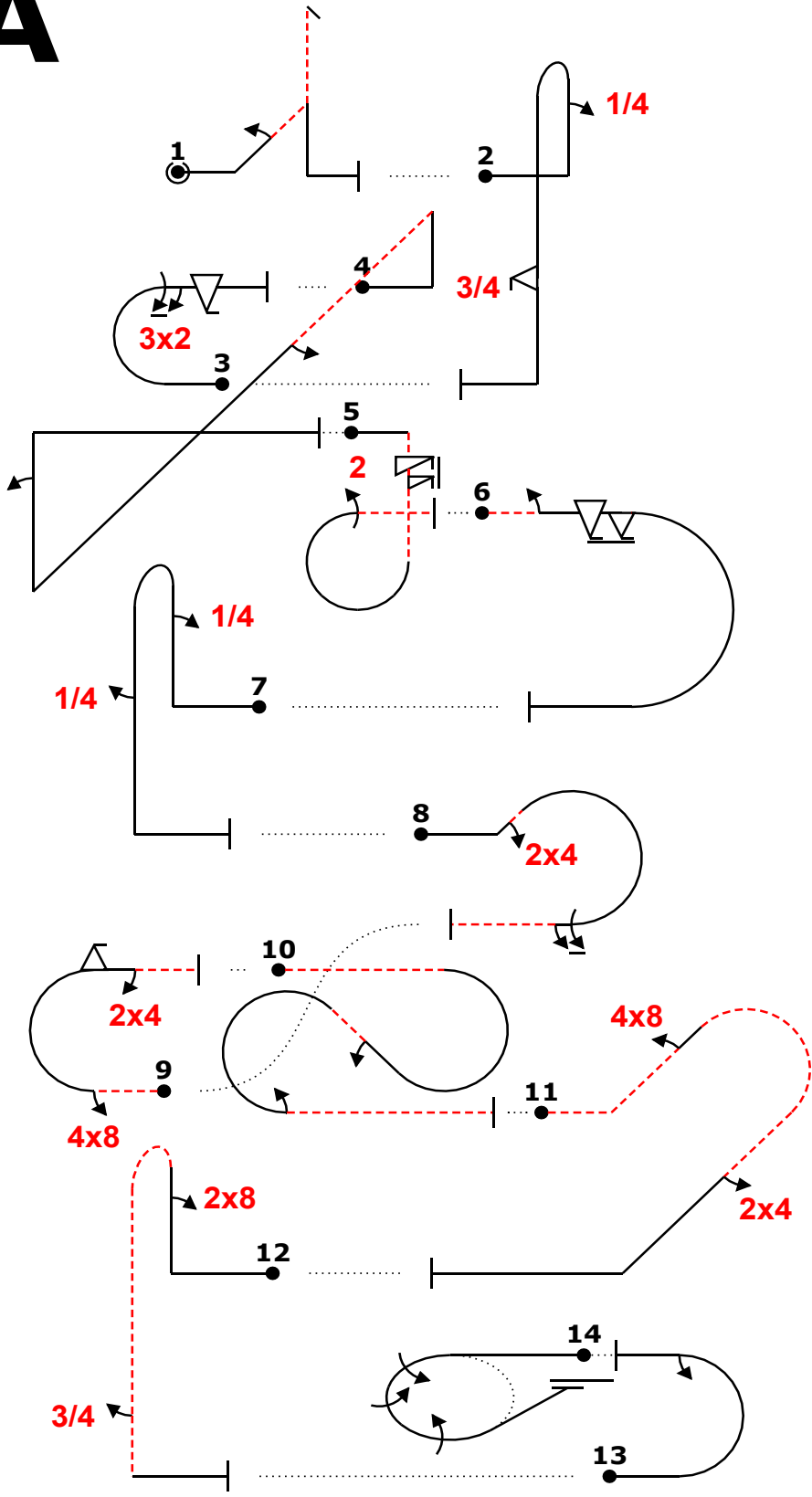

Fig	Grade	Pos	Remarks
1	.		
2	.		
3	.		
4	.		
5	.		
6	.		
7	.		
8	.		
9	.		
10	.		
11	.		
12	.		
13	.		
14	.		

Positioning **30**

Too Low		Trg Violation	
Too High		Wing Rocks	
Interruptions		Disqual Fig	
Insertions		Other(note...)	

-2% "I" 2dh (4,0) -2% "C" ,4b...3f. (-11,0) -2% "A" m,32;f (2,0) -5% "L" ~+n(.....'2.....).....2'  
 '+++++++~ (-2,0) -2% "G" 6sirr22- (-1,0) 6% "D" ~2,6fa (-13,0) "L" +,4b,4.' (8,0) 1% "H" .....  
 ,24~~~~rc6-~~~~ (-14,11) "B" -48m2f,24- (1,0) "L" ~~~~~iac(2)2~~~~ (-1,0) "F" -48rdb24.. (-6,0) "J" ~  
 ,8pb...3 (20,0) "L" m2 (2,0) "E" 3j3>

Fig 1 I	K	Fig 2 C	K	Fig 3 A	K	Fig 4 L	K	Fig 5 G	K	Fig 6 D	K	Fig 7 L	K	Fig 8 H	K	Fig 9 B	K	Fig 10 L	K	Fig 11 F	K	Fig 12 J	K	Fig 13 L	K	Fig 14 E	K
5.3.2.1	24	8.4.1.1	13	7.2.2.1	6	1.3.12.1	21	8.6.3.3	13	7.2.1.4	6	8.4.1.1	13	8.5.4.1	11	7.2.3.2	7	7.5.7.4	15	8.4.16.2	16	8.4.3.1	15	7.2.2.1	6	2.3.4.1	30
9.1.2.2	6	9.1.1.1	6	9.2.3.6	12	9.1.4.2	4	9.11.1.6	3	9.1.3.2	4	9.1.1.1	6	9.4.2.2	7	9.8.3.2	7	9.1.2.2	6	9.8.2.2	9	9.8.1.1	7	9.1.3.2	4		
		9.9.5.3	11	9.9.3.4	11	9.1.1.2	8	9.2.3.4	9	9.9.3.6	14	9.1.5.1	2	9.1.3.6	10	9.9.3.2	11	9.1.3.2	4	9.4.4.2	5	9.1.5.3	6				
	<b>30</b>		<b>30</b>		<b>29</b>		<b>6</b>		<b>25</b>		<b>24</b>		<b>6</b>		<b>28</b>		<b>30</b>		<b>6</b>		<b>30</b>		<b>28</b>		<b>6</b>		<b>30</b>

Pilot:

A/C:

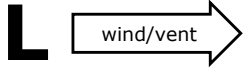

**A**

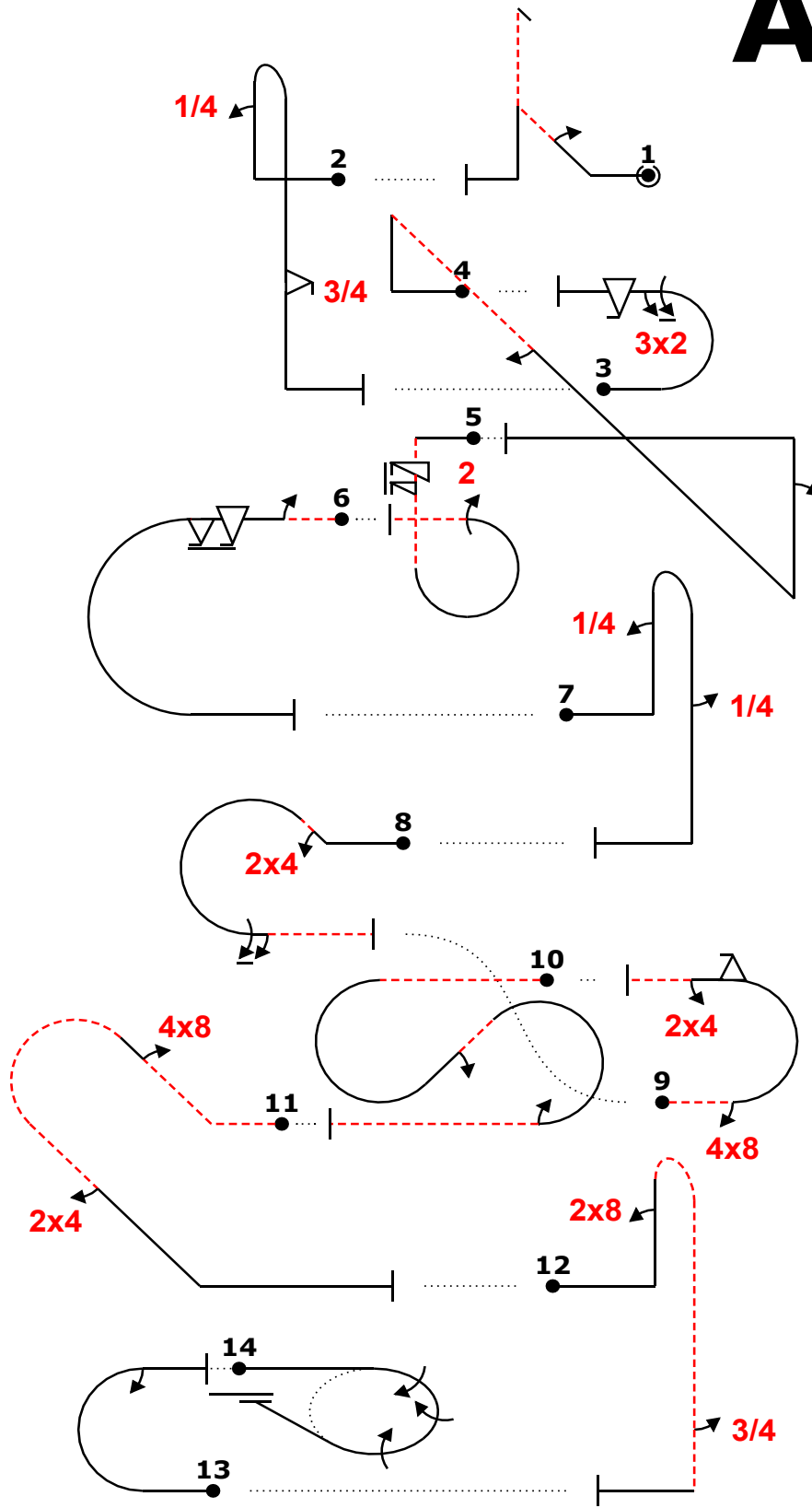

Fig	Grade	Pos	Remarks
1	.		
2	.		
3	.		
4	.		
5	.		
6	.		
7	.		
8	.		
9	.		
10	.		
11	.		
12	.		
13	.		
14	.		

Positioning  
**30**

Too Low		Trg Violation	
Too High		Wing Rocks	
Interruptions		Disqual Fig	
Insertions		Other(note...)	

-2% "I" 2dh (4,0) -2% "C" ,4b...3f.' (-11,0) -2% "A" m,32;f (2,0) -5% "L" ~+n(.....)'2.....)....2'  
 '+++++++~ (-2,0) -2% "G" 6sirr22- (-1,0) 6% "D" ~'2,6fa (-13,0) "L" '+,4b,4.' (8,0) 1% "H" ~~~~~  
 ,24~~~~rc6-~~~~ (-14,11) "B" -48m2f,24- (1,0) "L" ~~~~~iac(2)2-~ (-1,0) "F" -48rdb24..' (-6,0) "J" ~  
 ,8pb...;3 (20,0) "L" m2 (2,0) "E" 3j3>

Fig 1 I	K	Fig 2 C	K	Fig 3 A	K	Fig 4 L	K	Fig 5 G	K	Fig 6 D	K	Fig 7 L	K	Fig 8 H	K	Fig 9 B	K	Fig 10 L	K	Fig 11 F	K	Fig 12 J	K	Fig 13 L	K	Fig 14 E	K
5.3.2.1	24	8.4.1.1	13	7.2.2.1	6	1.3.12.1	21	8.6.3.3	13	7.2.1.4	6	8.4.1.1	13	8.5.4.1	11	7.2.3.2	7	7.5.7.4	15	8.4.16.2	16	8.4.3.1	15	7.2.2.1	6	2.3.4.1	30
9.1.2.2	6	9.1.1.1	6	9.2.3.6	12	9.1.4.2	4	9.11.1.6	3	9.1.3.2	4	9.1.1.1	6	9.4.2.2	7	9.8.3.2	7	9.1.2.2	6	9.8.2.2	9	9.8.1.1	7	9.1.3.2	4		
		9.9.5.3	11	9.9.3.4	11	9.1.1.2	8	9.2.3.4	9	9.9.3.6	14	9.1.5.1	2	9.1.3.6	10	9.9.3.2	11	9.1.3.2	4	9.4.4.2	5	9.1.5.3	6				
	<b>30</b>		<b>30</b>		<b>29</b>		<b>6</b>		<b>25</b>		<b>24</b>		<b>6</b>		<b>28</b>		<b>30</b>		<b>6</b>		<b>30</b>		<b>28</b>		<b>6</b>		<b>30</b>

Pilot:

A/C:

# B

← wind/vent **R**

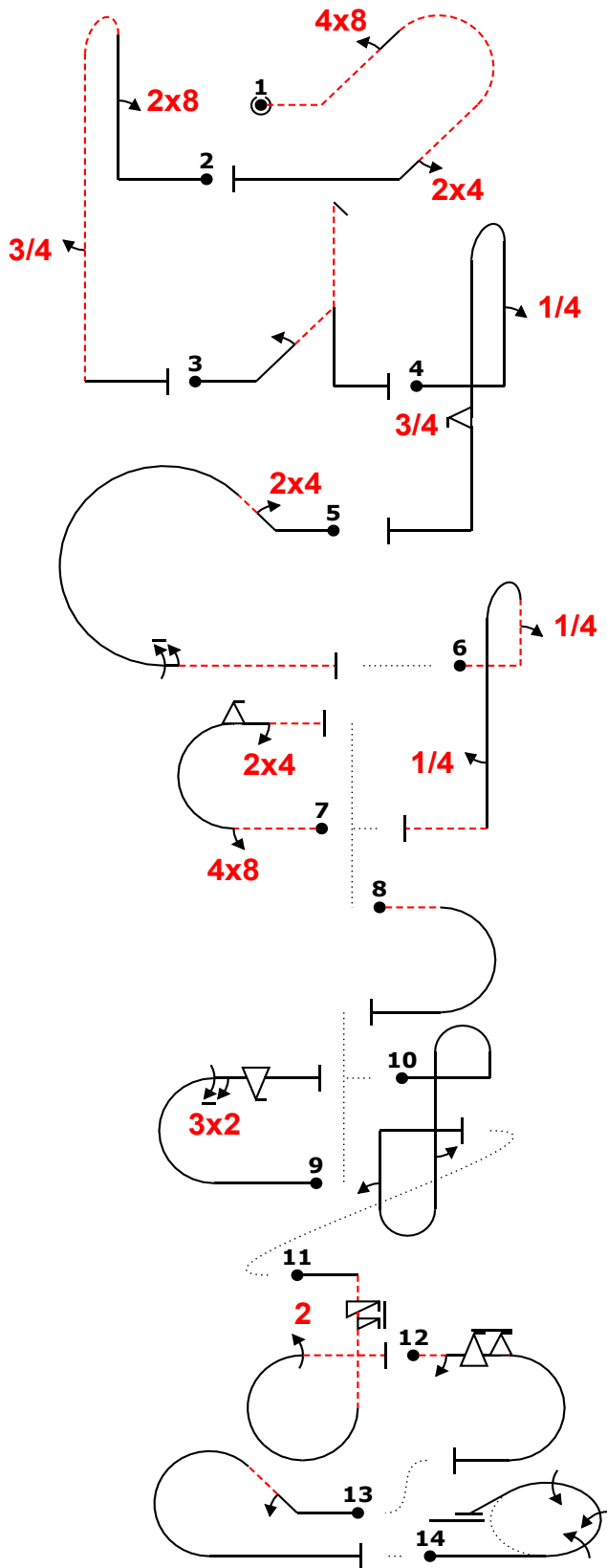

Fig	Grade	Pos	Remarks
1	.		
2	.		
3	.		
4	.		
5	.		
6	.		
7	.		
8	.		
9	.		
10	.		
11	.		
12	.		
13	.		
14	.		

Positioning **30** .

Too Low		Trg Violation	
Too High		Wing Rocks	
Interruptions		Disqual Fig	
Insertions		Other(note...)	

"@F" -48rdb24 "@J" ,8.pb...;3.. "@I" 2dh "@C" ,4.b...;3f.' "@H" 2> 9% "+ .....;24" rc6- ..... [5,0] "@L  
 " .....;4b...'4' (-2,0) "@B" -'48m2f,24- [0,14] "@L" -a~ [0,13] "@A" .m,32;f (2,0) "@L" .....bb("2) (-16,11  
 ) "@G" 6sirr22- "@D" -' ,2,6fa (-3,4) "@L" ..... 2"rc+ ..... (1,0) "@E" 3j3+.....

Fig	F	K	Fig	J	K	Fig	I	K	Fig	C	K	Fig	H	K	Fig	L	K	Fig	B	K	Fig	L	K	Fig	A	K	Fig	L	K	Fig	D	K	Fig	L	K	Fig	E	K
8.4.16.2	16	8.4.3.1	15	5.3.2.1	24	8.4.1.1	13	8.5.4.1	11	8.4.3.2	16	7.2.3.2	7	7.2.1.4	6	7.2.2.1	6	8.8.2.1	19	8.6.3.3	13	7.2.1.4	6	8.5.2.1	10	2.3.4.1	30											
9.8.2.2	9	9.8.1.1	7	9.1.2.2	6	9.1.1.1	6	9.4.2.2	7	9.1.1.1	6	9.8.3.2	7	9.2.3.6	12	9.1.5.2	4	9.1.1.6	3	9.1.3.2	4	9.1.2.2	6															
9.4.4.2	5	9.1.5.3	6			9.9.5.3	11	9.1.3.6	10	9.1.5.1	2	9.9.3.2	11	9.9.3.4	11	9.1.1.2	8	9.2.3.4	9	9.9.3.6	14																	
	<b>30</b>		<b>28</b>		<b>30</b>		<b>30</b>		<b>28</b>		<b>6</b>		<b>30</b>		<b>6</b>		<b>29</b>		<b>6</b>		<b>25</b>		<b>24</b>		<b>6</b>		<b>30</b>											

Pilot:

A/C:



Judges Name		Flight #
Signature	Number	

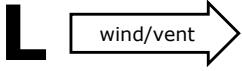

# B

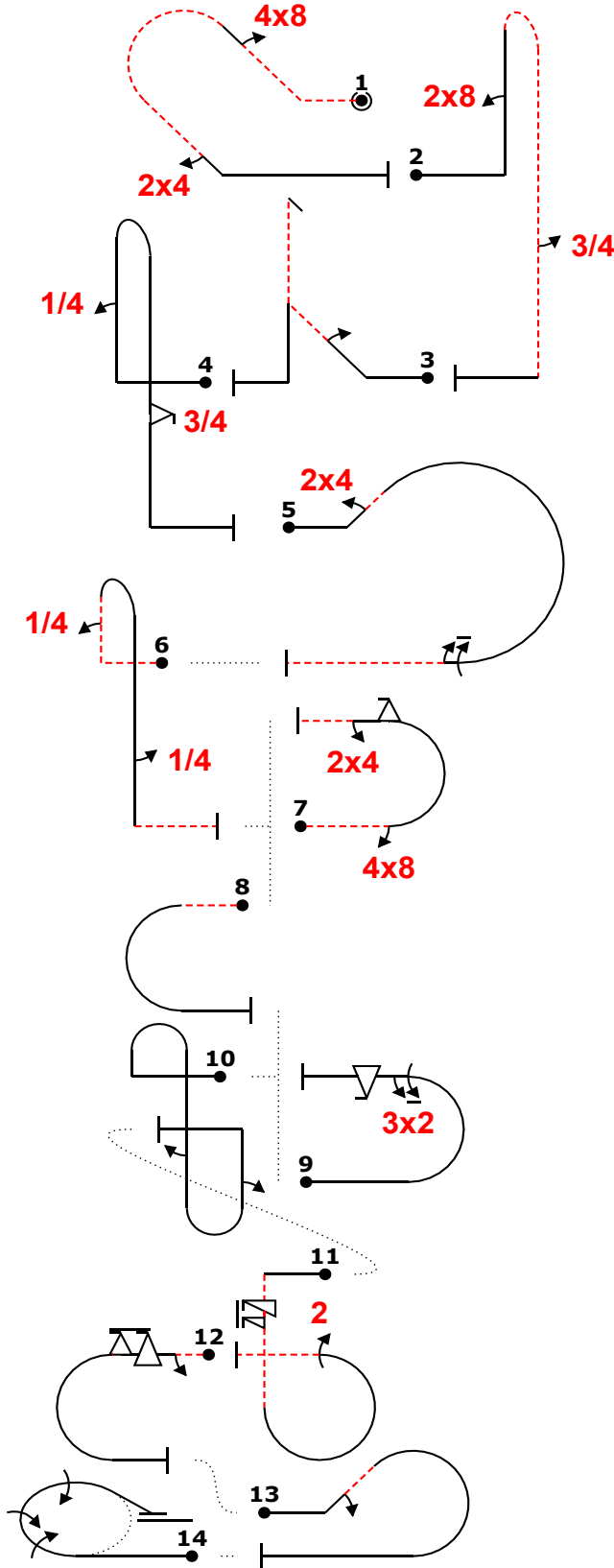

Fig	Grade	Pos	Remarks
1	.		
2	.		
3	.		
4	.		
5	.		
6	.		
7	.		
8	.		
9	.		
10	.		
11	.		
12	.		
13	.		
14	.		

Positioning	<b>30</b>	.
-------------	-----------	---

Too Low		Trg Violation	
Too High		Wing Rocks	
Interruptions		Disqual Fig	
Insertions		Other(note...)	

"@F" -48rdb24 "@J" ,8.pb...,3.. "@I" 2dh "@C" ,4.b...,3f.' "@H" 2> 9% ``+.....,24``rc6..... [5,0] "@L" ``.....,4b.,,4'- (-2,0) "@B" ``'48m2f,24- [0,14] "@L" -a- [0,13] "@A" .m,32;f (2,0) "@L" ``.....bb(``2)2 (-16,11) "@G" 6sirp22- "@D" -',,2,6fa (-3,4) "@L" ``.....2``rc+..... (1,0) "@E" 3j3+.....

Fig	F K	Fig 2 J K	Fig 3 I K	Fig 4 C K	Fig 5 H K	Fig 6 L K	Fig 7 B K	Fig 8 L K	Fig 9 A K	Fig 10 L K	Fig 11 G K	Fig 12 D K	Fig 13 L K	Fig 14 E K													
8.4.16.2	16	8.4.3.1	15	5.3.2.1	24	8.4.1.1	13	8.5.4.1	11	8.4.3.2	16	7.2.3.2	7	7.2.1.4	6	7.2.2.1	6	8.8.2.1	19	8.6.3.3	13	7.2.1.4	6	8.5.2.1	10	2.3.4.1	30
9.8.2.2	9	9.8.1.1	7	9.1.2.2	6	9.1.1.1	6	9.4.2.2	7	9.1.1.1	6	9.8.3.2	7	9.2.3.6	12	9.1.5.2	4	9.11.1.6	3	9.1.3.2	4	9.1.2.2	6				
9.4.4.2	5	9.1.5.3	6			9.9.5.3	11	9.1.3.6	10	9.1.5.1	2	9.9.3.2	11	9.9.3.4	11	9.1.1.2	8	9.2.3.4	9	9.9.3.6	14						
	<b>30</b>		<b>28</b>		<b>30</b>		<b>30</b>		<b>28</b>		<b>6</b>		<b>30</b>		<b>6</b>		<b>29</b>		<b>6</b>		<b>25</b>		<b>24</b>		<b>6</b>		<b>30</b>

Pilot:

A/C:

**C**

wind/vent ← **R**

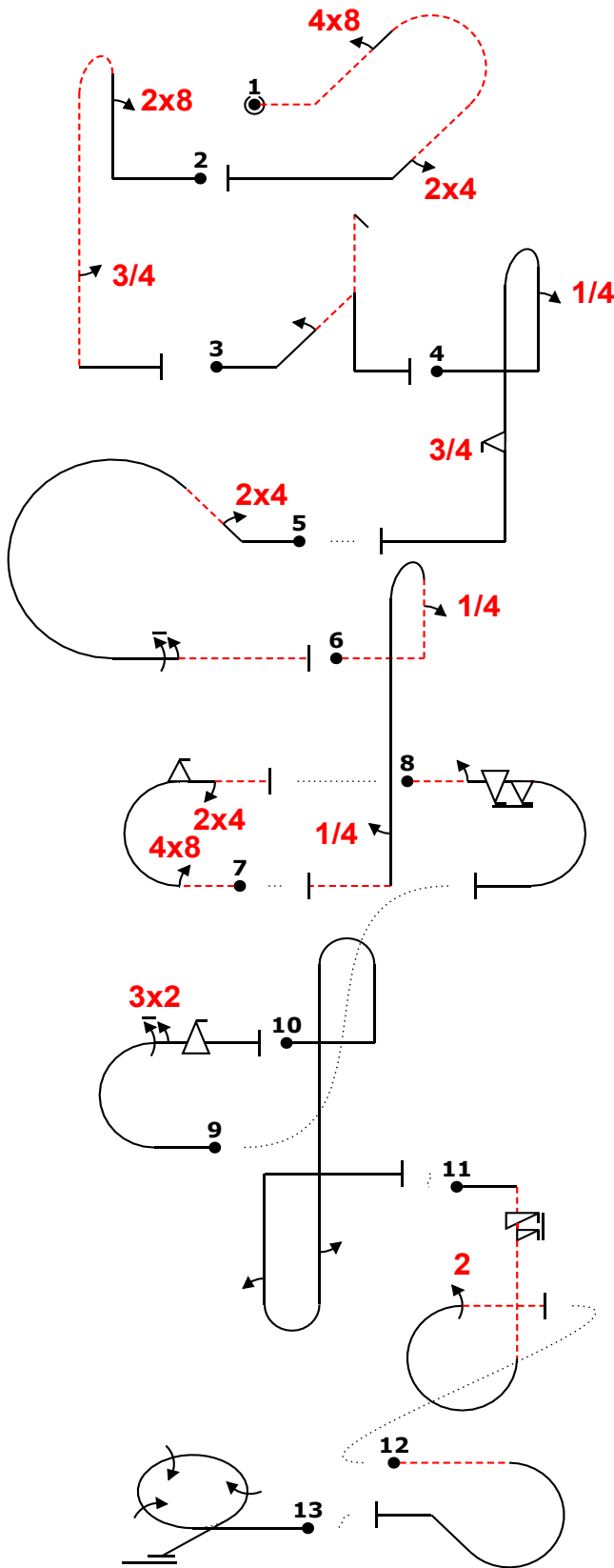

Fig	Grade	Pos	Remarks
1	.		
2	.		
3	.		
4	.		
5	.		
6	.		
7	.		
8	.		
9	.		
10	.		
11	.		
12	.		
13	.		

Positioning **30** .

Too Low		Trg Violation	
Too High		Wing Rocks	
Interruptions		Disqual Fig	
Insertions		Other(note...)	

"@F" -48rdb24 "@J" ,8pb...13. (0,0) "@I" 2dh(") "@C" ~,4b...,3f.+ (-2,0) "@H" 9% "" +.....,24"rc"16-.....  
 "@L" ~,4b...,4- (-1,0) "@B" ~,48m2f,24- (6,0) "@D" ~,2,6fa (-15,20) "@A" m32;f "@L" bb(....2).'+ (0,1)  
 "@G" 6s.irp22- (-15,12) "@L" ~,.....ic..... (-1,1) "@E" 3j3

Fig 1 F	K	Fig 2 J	K	Fig 3 I	K	Fig 4 C	K	Fig 5 H	K	Fig 6 L	K	Fig 7 B	K	Fig 8 D	K	Fig 9 A	K	Fig 10 L	K	Fig 11 G	K	Fig 12 L	K	Fig 13 E	K
8.4.16.2	16	8.4.3.1	15	5.3.2.1	24	8.4.1.1	13	8.5.4.1	11	8.4.3.2	16	7.2.3.2	7	7.2.1.4	6	7.2.2.1	6	8.8.2.1	19	8.6.3.3	13	8.5.5.4	10	2.3.4.1	30
9.8.2.2	9	9.8.1.1	7	9.1.2.2	6	9.1.1.1	6	9.4.2.2	7	9.1.1.1	6	9.8.3.2	7	9.1.3.2	4	9.2.3.6	12	9.1.5.2	4	9.1.1.6	3				
9.4.4.2	5	9.1.5.3	6			9.9.5.3	11	9.1.3.6	10	9.1.5.1	2	9.9.3.2	11	9.9.3.6	14	9.9.3.4	11	9.1.1.2	8	9.2.3.4	9				
	<b>30</b>		<b>28</b>		<b>30</b>		<b>30</b>		<b>28</b>		<b>8</b>		<b>30</b>		<b>24</b>		<b>29</b>		<b>8</b>		<b>25</b>		<b>8</b>		<b>30</b>

Pilot:

A/C:

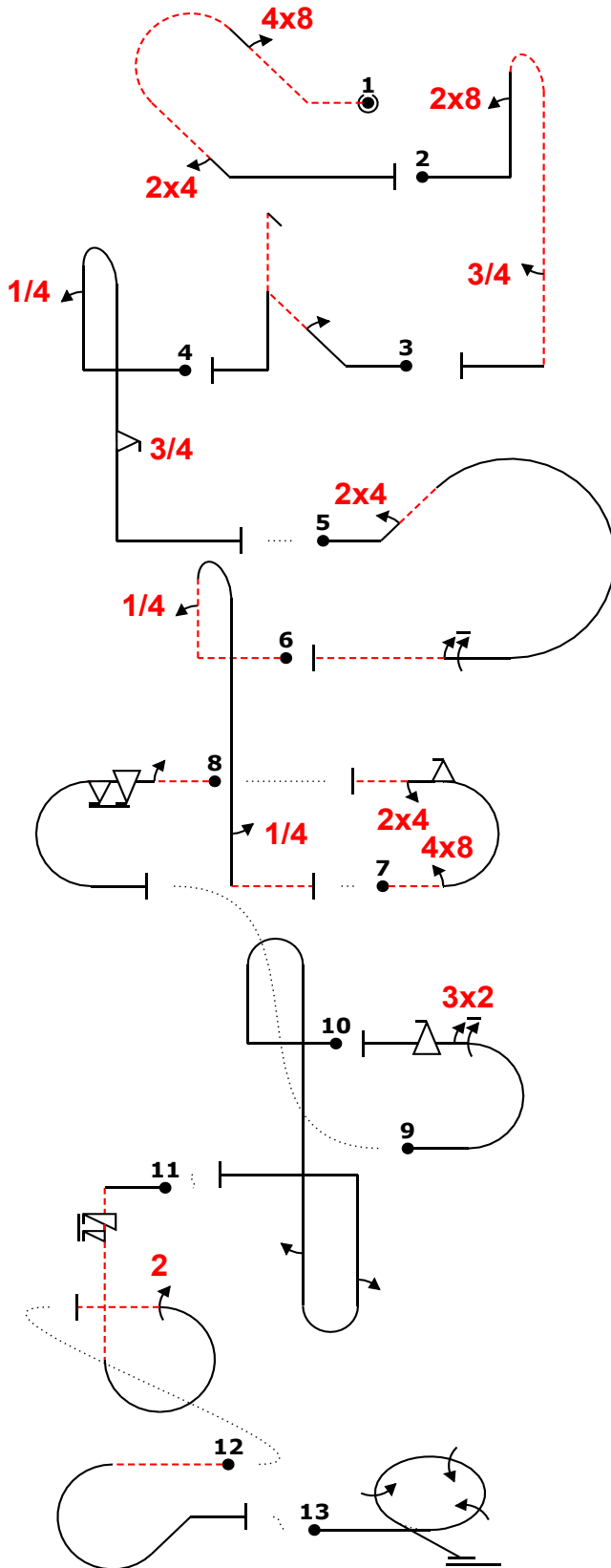
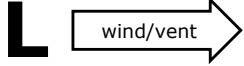

Fig	Grade	Pos	Remarks
1	.		
2	.		
3	.		
4	.		
5	.		
6	.		
7	.		
8	.		
9	.		
10	.		
11	.		
12	.		
13	.		

Positioning  
30

Too Low		Trg Violation	
Too High		Wing Rocks	
Interruptions		Disqual Fig	
Insertions		Other(note...)	

"@F" -48rdb24 "@J" ,8pb...13. (0,0) "@I" 2dh(") "@C" ~,4b...,3f.+ (-2,0) "@H" 9% "" + "24"rc"16-  
 "L" ~,4b...,4- (-1,0) "@B" -,48m2f,24- (6,0) "@D" -2,6fa (-15,20) "@A" m32;f "@L" bb(....2).'+ (0,1)  
 "@G" 6s.irp22- (-15,12) "@L" - "ic" ( -1,1) "@E" 3j3

Fig 1 F	K	Fig 2 J	K	Fig 3 I	K	Fig 4 C	K	Fig 5 H	K	Fig 6 L	K	Fig 7 B	K	Fig 8 D	K	Fig 9 A	K	Fig 10 L	K	Fig 11 G	K	Fig 12 L	K	Fig 13 E	K
8.4.16.2	16	8.4.3.1	15	5.3.2.1	24	8.4.1.1	13	8.5.4.1	11	8.4.3.2	16	7.2.3.2	7	7.2.1.4	6	7.2.2.1	6	8.8.2.1	19	8.6.3.3	13	8.5.5.4	10	2.3.4.1	30
9.8.2.2	9	9.8.1.1	7	9.1.2.2	6	9.1.1.1	6	9.4.2.2	7	9.1.1.1	6	9.8.3.2	7	9.1.3.2	4	9.2.3.6	12	9.1.5.2	4	9.1.1.6	3				
9.4.4.2	5	9.1.5.3	6			9.9.5.3	11	9.1.3.6	10	9.1.5.1	2	9.9.3.2	11	9.9.3.6	14	9.9.3.4	11	9.1.1.2	8	9.2.3.4	9				
	<b>30</b>		<b>28</b>		<b>30</b>		<b>30</b>		<b>28</b>		<b>8</b>		<b>30</b>		<b>24</b>		<b>29</b>		<b>8</b>		<b>25</b>		<b>8</b>		<b>30</b>

Pilot:

A/C:

**D**

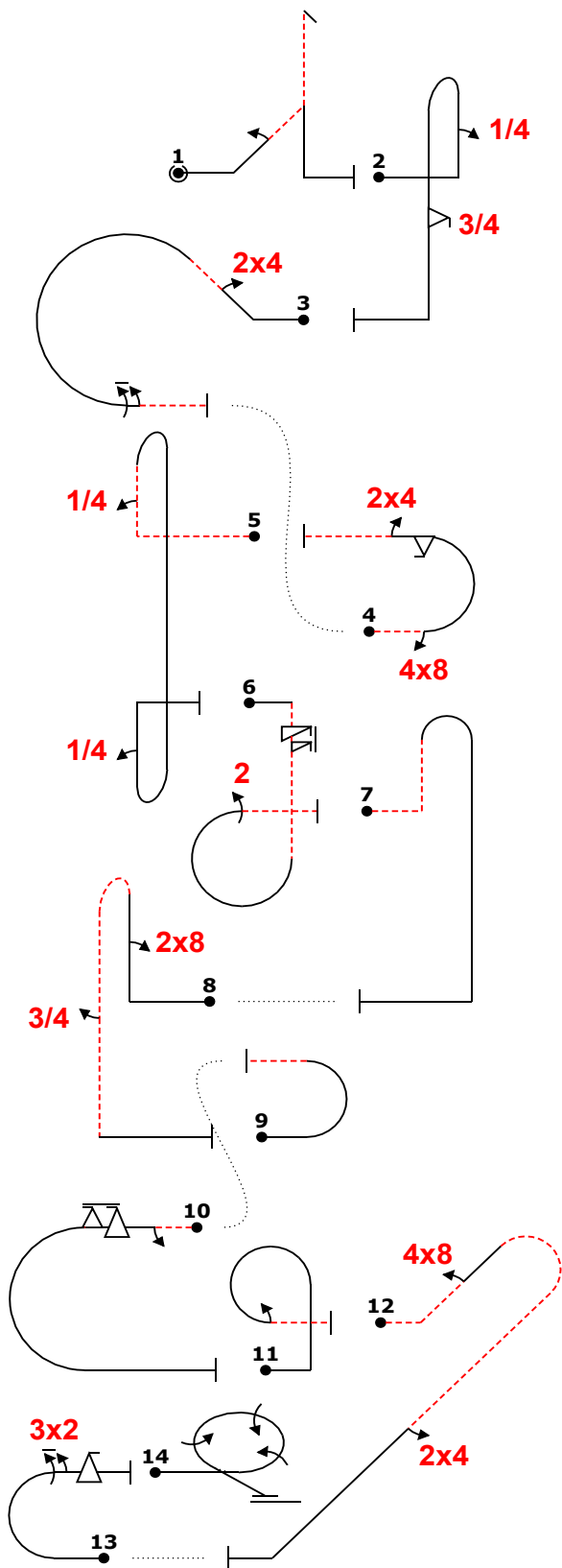
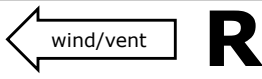

Fig	Grade	Pos	Remarks
1	.		
2	.		
3	.		
4	.		
5	.		
6	.		
7	.		
8	.		
9	.		
10	.		
11	.		
12	.		
13	.		
14	.		

Positioning	.
<b>30</b>	

Too Low		Trg Violation	
Too High		Wing Rocks	
Interruptions		Disqual Fig	
Insertions		Other(note...)	

"@I" 2dh "@C" "4'b.3f." (0,0) "@H" 8% "24" "rc6" (9,19) "@B" "-48m2f,24-- (0,0) "@L" -- "4' 'bb(...)' '4+ (0,0) "@G" "+6s.irp22- (0,0) "@L" "b...+ (-8,0) "@J" ",8' 'pb.,3..+ (0,0) "@L" "-2% m~ (0,14) "@D" 5% -'2',6fa+ (0,0) -2% "@L" "rp2- (0,0) "@F" -3% -48.'rdb.....' '24.' '24.' '24.' '24.' (-6,0) "@A" -1% m32;f+ "@E" -1% /+3j3

Fig 1 I	K	Fig 2 C	K	Fig 3 H	K	Fig 4 B	K	Fig 5 L	K	Fig 6 G	K	Fig 7 L	K	Fig 8 J	K	Fig 9 L	K	Fig 10 D	K	Fig 11 L	K	Fig 12 F	K	Fig 13 A	K	Fig 14 E	K
5.3.2.1	24	8.4.1.1	13	8.5.4.1	11	7.2.3.2	7	8.8.7.2	21	8.6.3.3	13	8.4.4.2	14	8.4.3.1	15	7.2.1.1	6	7.2.1.4	6	8.6.2.1	12	8.4.16.2	16	7.2.2.1	6	2.3.4.1	30
9.1.2.2	6	9.1.1.1	6	9.4.2.2	7	9.8.3.2	7	9.1.1.1	6	9.11.1.6	3			9.8.1.1	7			9.1.3.2	4	9.1.3.2	4	9.8.2.2	9	9.2.3.6	12		
		9.9.5.3	11	9.1.3.6	10	9.9.3.2	11	9.1.1.1	6	9.2.3.4	9			9.1.5.3	6							9.4.4.2	5	9.9.3.4	11		
	<b>30</b>		<b>30</b>		<b>28</b>		<b>30</b>		<b>6</b>		<b>25</b>		<b>6</b>		<b>28</b>		<b>6</b>		<b>24</b>		<b>6</b>		<b>30</b>		<b>29</b>		<b>30</b>

Pilot:

A/C:

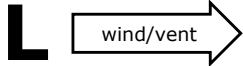

# D

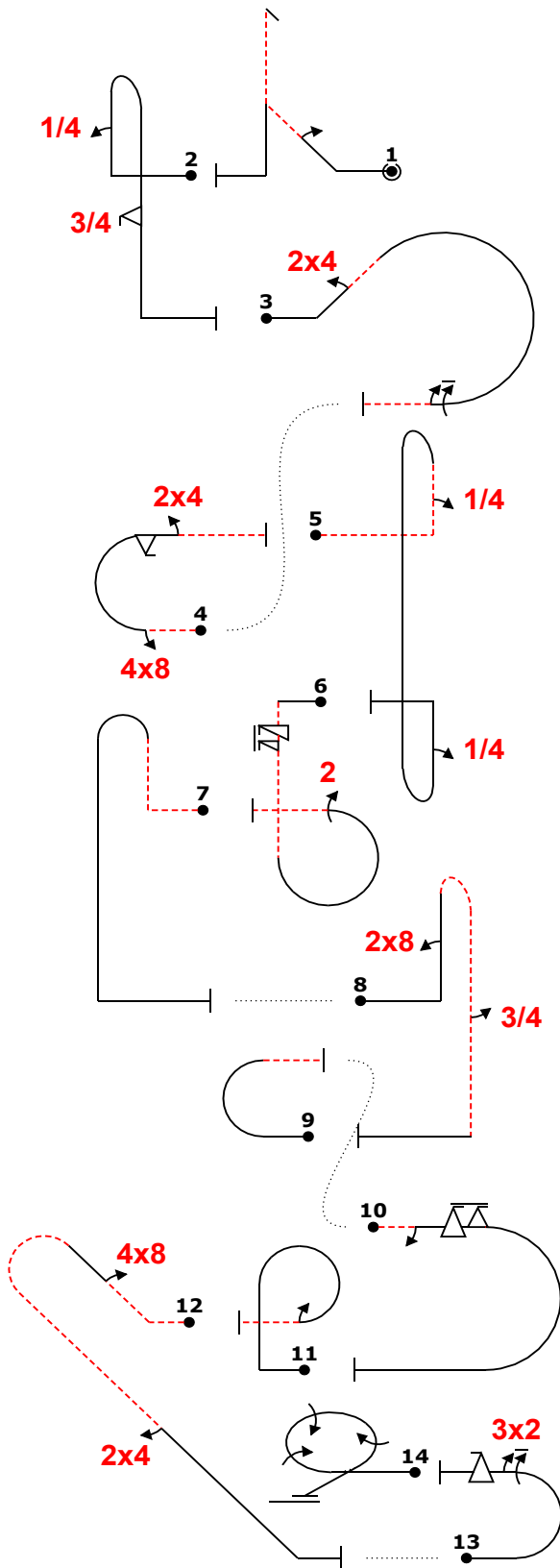

Fig	Grade	Pos	Remarks
1	.		
2	.		
3	.		
4	.		
5	.		
6	.		
7	.		
8	.		
9	.		
10	.		
11	.		
12	.		
13	.		
14	.		

Positioning	.
<b>30</b>	.

Too Low		Trg Violation	
Too High		Wing Rocks	
Interruptions		Disqual Fig	
Insertions		Other(note...)	

"@I" 2dh "@C" "4'b.3f." (0,0) "@H" 8% "24" "rc6" (9,19) "@B" "-48m2f,24-- (0,0) "@L" --  
 "4'bb(...)" "4+ (0,0) "@G" "+6s.irp22- (0,0) "@L" "b....+ (-8,0) "@J" "8'pb.,3..+ (0,0) "@L" "-2% m~ (0,14) "@D" 5% "2",6fa+ (0,0) "-2% "@L" "rp2- (0,0) "@F" "-3% "-48.'rdb.....' "24" "1+ " (-6,0) "@A" -1% m32;f+ "@E" -1% / "+3j3

Fig 1 I	K	Fig 2 C	K	Fig 3 H	K	Fig 4 B	K	Fig 5 L	K	Fig 6 G	K	Fig 7 L	K	Fig 8 J	K	Fig 9 L	K	Fig 10 D	K	Fig 11 L	K	Fig 12 F	K	Fig 13 A	K	Fig 14 E	K
5.3.2.1	24	8.4.1.1	13	8.5.4.1	11	7.2.3.2	7	8.8.7.2	21	8.6.3.3	13	8.4.4.2	14	8.4.3.1	15	7.2.1.1	6	7.2.1.4	6	8.6.2.1	12	8.4.16.2	16	7.2.2.1	6	2.3.4.1	30
9.1.2.2	6	9.1.1.1	6	9.4.2.2	7	9.8.3.2	7	9.1.1.1	6	9.11.1.6	3			9.8.1.1	7			9.1.3.2	4	9.1.3.2	4	9.8.2.2	9	9.2.3.6	12		
		9.9.5.3	11	9.1.3.6	10	9.9.3.2	11	9.1.1.1	6	9.2.3.4	9			9.1.5.3	6			9.9.3.6	14			9.4.4.2	5	9.9.3.4	11		
	<b>30</b>		<b>30</b>		<b>28</b>		<b>30</b>		<b>6</b>		<b>25</b>		<b>6</b>		<b>28</b>		<b>6</b>		<b>24</b>		<b>6</b>		<b>30</b>		<b>29</b>		<b>30</b>

Pilot:

A/C:



**E**

wind/vent ← **R**

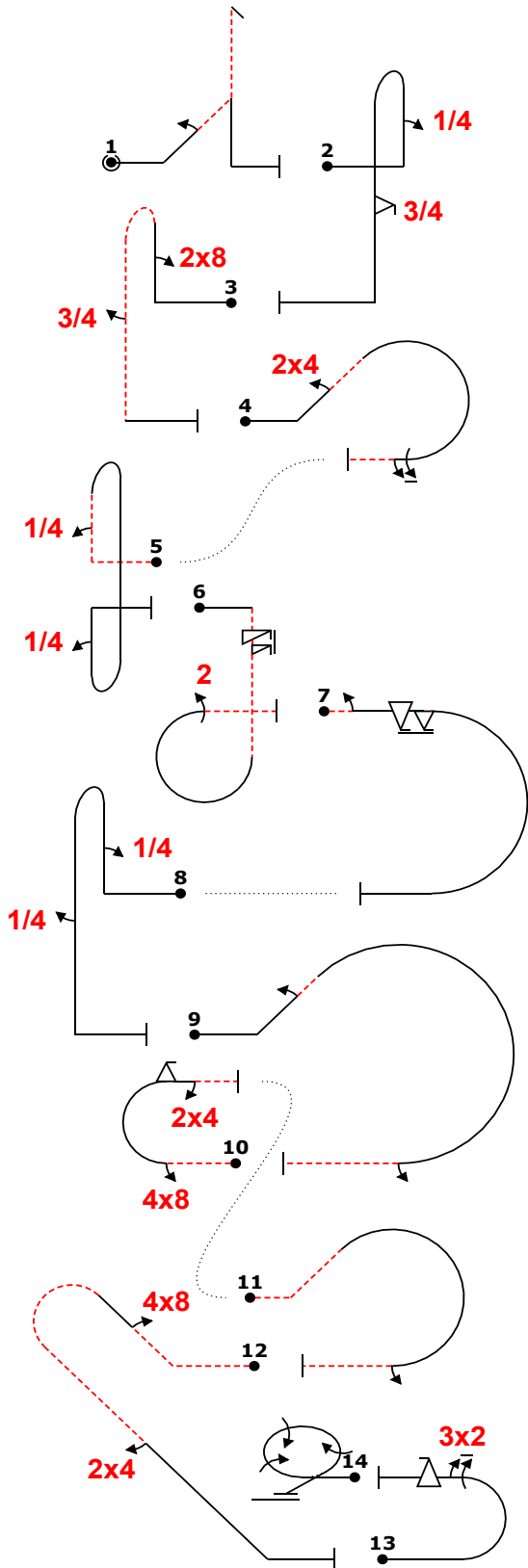

Fig	Grade	Pos	Remarks
1	.		
2	.		
3	.		
4	.		
5	.		
6	.		
7	.		
8	.		
9	.		
10	.		
11	.		
12	.		
13	.		
14	.		

Positioning **30** .

Too Low		Trg Violation	
Too High		Wing Rocks	
Interruptions		Disqual Fig	
Insertions		Other(note...)	

"@I" 2dh (0,0) "@C" 4'b.3f.~ (0,0) "@J" 8'pb'.3.' (0,0) "@H" 3% '+' 24'rc6- (-12,9)  
 "@L" 4'bb(')4+' (0,0) "@G" 6s.irp22- (0,0) "@D" 10% 2,6fa+ (-11,0) "@L" 4'b.,4.. (0,0) 14% "@  
 L" 2'rc2- (0,0) "@B" -1% -'48m2f,24- (-3,19) "@L" 5% rc2- (0,0) "  
 "@F" -2% ~,48.rdb.,,24.....+' (0,0) "@A" -1% ~'m,32;f "@E" -2% ~+3j3+

Fig 1 I	K	Fig 2 C	K	Fig 3 J	K	Fig 4 H	K	Fig 5 L	K	Fig 6 G	K	Fig 7 D	K	Fig 8 L	K	Fig 9 L	K	Fig 10 B	K	Fig 11 L	K	Fig 12 F	K	Fig 13 A	K	Fig 14 E	K
5.3.2.1	24	8.4.1.1	13	8.4.3.1	15	8.5.4.1	11	8.8.7.2	21	8.6.3.3	13	7.2.1.4	6	8.4.1.1	13	8.5.4.1	11	7.2.3.2	7	8.5.3.2	11	8.4.16.2	16	7.2.2.1	6	2.3.4.1	30
9.1.2.2	6	9.1.1.1	6	9.8.1.1	7	9.4.2.2	7	9.1.1.1	6	9.11.1.6	3	9.1.3.2	4	9.1.1.1	6	9.1.2.2	6	9.8.3.2	7	9.1.3.2	4	9.8.2.2	9	9.2.3.6	12		
		9.9.5.3	11	9.1.5.3	6	9.1.3.6	10	9.1.1.1	6	9.2.3.4	9	9.9.3.6	14	9.1.5.1	2	9.1.3.2	4	9.9.3.2	11			9.4.4.2	5	9.9.3.4	11		
	<b>30</b>		<b>30</b>		<b>28</b>		<b>28</b>		<b>6</b>		<b>25</b>		<b>24</b>		<b>6</b>		<b>6</b>		<b>30</b>		<b>6</b>		<b>30</b>		<b>29</b>		<b>30</b>

Pilot:

A/C:

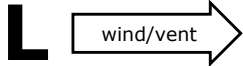

**E**

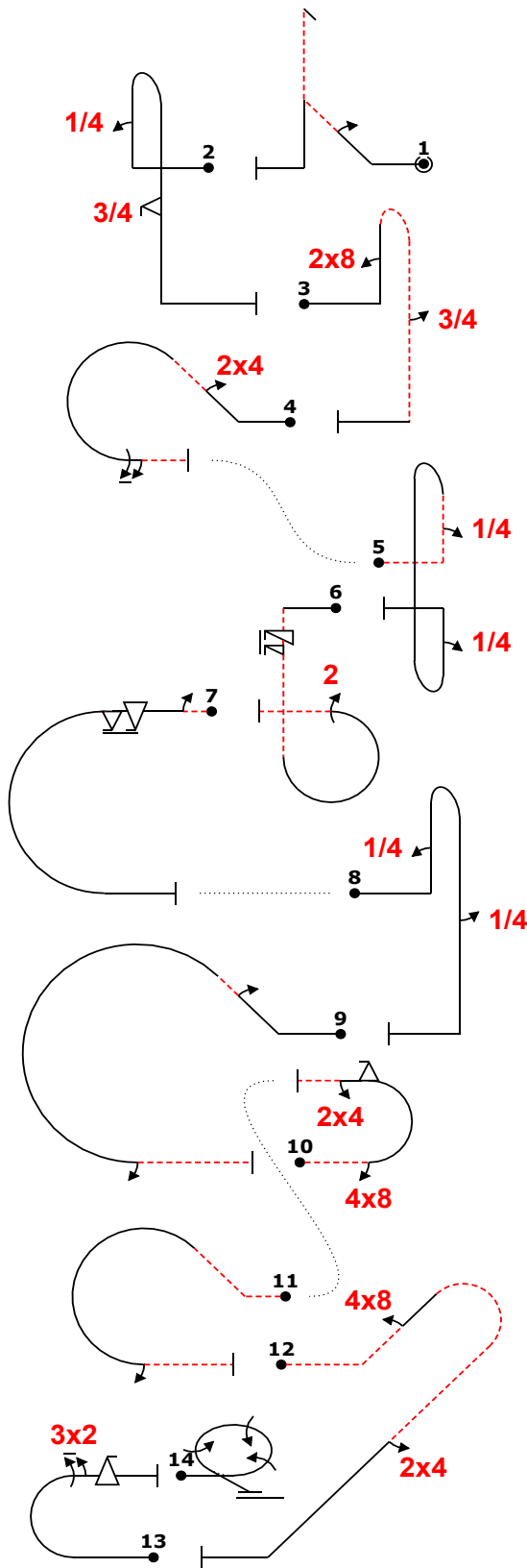

Fig	Grade	Pos	Remarks
1	.		
2	.		
3	.		
4	.		
5	.		
6	.		
7	.		
8	.		
9	.		
10	.		
11	.		
12	.		
13	.		
14	.		

Positioning	.
30	.

Too Low		Trg Violation	
Too High		Wing Rocks	
Interruptions		Disqual Fig	
Insertions		Other(note...)	

"@I" 2dh (0,0) "@C" 4'b.3f.~ (0,0) "@J" 8'pb'.3.~ (0,0) "@H" 3% + 24'rc6- (-12,9)  
"@L" 4'bb(')4+ (0,0) "@G" 6s.irp22- (0,0) "@D" 10% 2,6fa+ (-11,0) "@L" 4'b.4.. (0,0) 14% "@  
L" + 2'rc2- (0,0) "@B" -1% -48m2f,24- (-3,19) "@L" 5% rc2- (0,0) "  
@F" -2% ~,48.rdb.,,24.....+ (0,0) "@A" -1% ~'m,32;f "@E" -2% ~+3j3+

Fig 1 I	K	Fig 2 C	K	Fig 3 J	K	Fig 4 H	K	Fig 5 L	K	Fig 6 G	K	Fig 7 D	K	Fig 8 L	K	Fig 9 L	K	Fig 10 B	K	Fig 11 L	K	Fig 12 F	K	Fig 13 A	K	Fig 14 E	K
5.3.2.1	24	8.4.1.1	13	8.4.3.1	15	8.5.4.1	11	8.8.7.2	21	8.6.3.3	13	7.2.1.4	6	8.4.1.1	13	8.5.4.1	11	7.2.3.2	7	8.5.3.2	11	8.4.16.2	16	7.2.2.1	6	2.3.4.1	30
9.1.2.2	6	9.1.1.1	6	9.8.1.1	7	9.4.2.2	7	9.1.1.1	6	9.11.1.6	3	9.1.3.2	4	9.1.1.1	6	9.1.2.2	6	9.8.3.2	7	9.1.3.2	4	9.8.2.2	9	9.2.3.6	12		
		9.9.5.3	11	9.1.5.3	6	9.1.3.6	10	9.1.1.1	6	9.2.3.4	9	9.9.3.6	14	9.1.5.1	2	9.1.3.2	4	9.9.3.2	11			9.4.4.2	5	9.9.3.4	11		
	30		30		28		28		6		25		24		6		6		30		6		30		29		30

Pilot:

A/C:

Judges Name	
Signature	Number

Flight #
----------

**F**

**R**

wind/vent ←

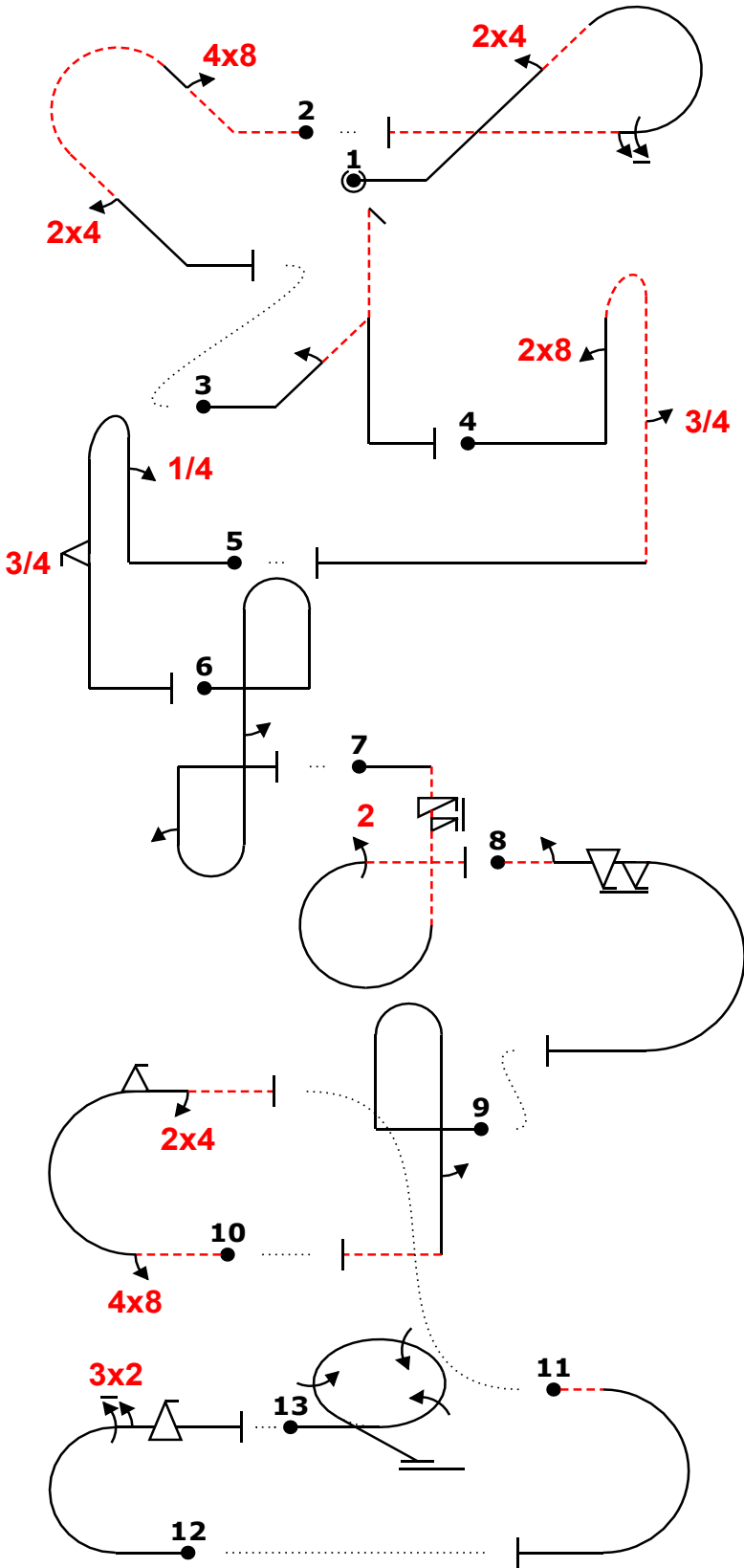

Fig	Grade	Pos	Remarks
1	.		
2	.		
3	.		
4	.		
5	.		
6	.		
7	.		
8	.		
9	.		
10	.		
11	.		
12	.		
13	.		

Positioning	30	.
-------------	----	---

Too Low		Trg Violation	
Too High		Wing Rocks	
Interruptions		Disqual Fig	
Insertions		Other(note...)	

"@H" /24rc6- (-1,0) "@F" -",48rdb",24." + ~~~~~ (-7,9) "@I" 2dh(") " " @J" /~8pb'13.' '++++~^ (-1,0) "@C" ,4 b,3f.' + "@L" "bb("2.)`2 (1,0) "@G" 6smp22- 5% "@D" -"2,6fa (0,5) "@L" "b.2'- (-3,0) 3% "@B" -48m2f,24- (13 ,19) "@L" 3% -"a (-16,0) "@A" /m32;f (-1,0) "@E" ""+3j3

Fig 1 H	K	Fig 2 F	K	Fig 3 I	K	Fig 4 J	K	Fig 5 C	K	Fig 6 L	K	Fig 7 G	K	Fig 8 D	K	Fig 9 L	K	Fig 10 B	K	Fig 11 L	K	Fig 12 A	K	Fig 13 E	K
8.5.4.1	11	8.4.16.2	16	5.3.2.1	24	8.4.3.1	15	8.4.1.1	13	8.8.2.1	19	8.6.3.3	13	7.2.1.4	6	8.4.2.1	14	7.2.3.2	7	7.2.1.4	6	7.2.2.1	6	2.3.4.1	30
9.4.2.2	7	9.8.2.2	9	9.1.2.2	6	9.8.1.1	7	9.1.1.1	6	9.1.5.2	4	9.11.1.6	3	9.1.3.2	4	9.1.5.2	4	9.8.3.2	7			9.2.3.6	12		
9.1.3.6	10	9.4.4.2	5			9.1.5.3	6	9.9.5.3	11	9.1.1.2	8	9.2.3.4	9	9.9.3.6	14			9.9.3.2	11			9.9.3.4	11		
																		9.4.3.2	5						
	<b>28</b>		<b>30</b>		<b>30</b>		<b>28</b>		<b>30</b>		<b>8</b>		<b>25</b>		<b>24</b>		<b>8</b>		<b>30</b>		<b>8</b>		<b>29</b>		<b>30</b>

Pilot:

A/C:

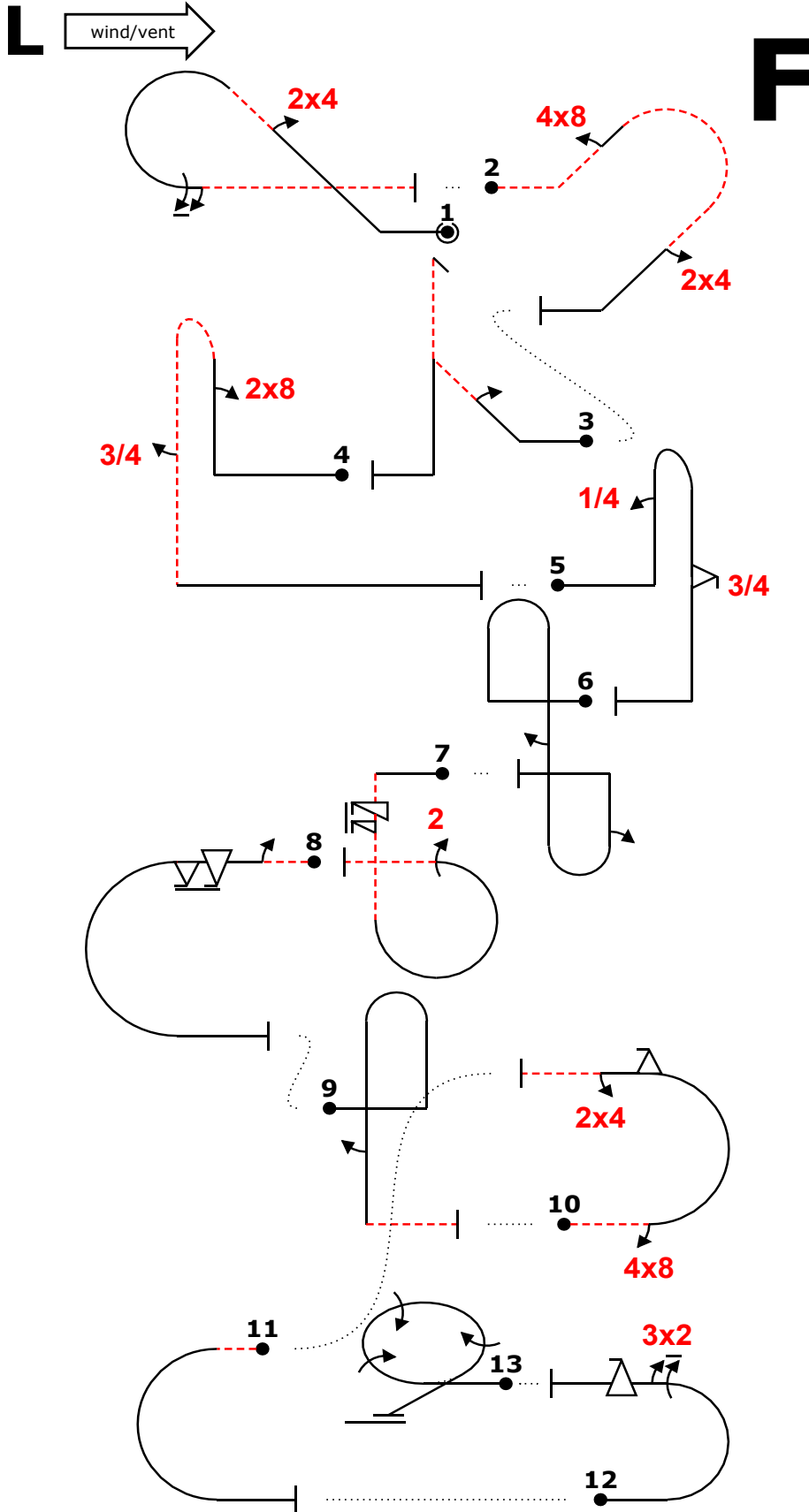

Fig	Grade	Pos	Remarks
1	.		
2	.		
3	.		
4	.		
5	.		
6	.		
7	.		
8	.		
9	.		
10	.		
11	.		
12	.		
13	.		

Positioning

30

.

Too Low

Trg Violation

Too High

Wing Rocks

Interruptions

Disqual Fig

Insertions

Other(note...)

"@H" /24rc6- (-1,0) "@F" -",48rdb",24." + ~~~~~ (-7,9) "@I" 2dh(") ""@J" /~-8pb'13.' '++++~^ (-1,0) "@C" ,4 b,3f.+ " @L" `bb("2.)`2 (1,0) "@G" 6smp22- 5% "@D" -"2,6fa (0,5) "@L" `b.2'- (-3,0) 3% "@B" -48m2f,24- (13 ,19) "@L" 3% -"a (-16,0) "@A" /m32;f (-1,0) "@E" ~~~+3j3

Fig 1 H	K	Fig 2 F	K	Fig 3 I	K	Fig 4 J	K	Fig 5 C	K	Fig 6 L	K	Fig 7 G	K	Fig 8 D	K	Fig 9 L	K	Fig 10 B	K	Fig 11 L	K	Fig 12 A	K	Fig 13 E	K
8.5.4.1	11	8.4.16.2	16	5.3.2.1	24	8.4.3.1	15	8.4.1.1	13	8.8.2.1	19	8.6.3.3	13	7.2.1.4	6	8.4.2.1	14	7.2.3.2	7	7.2.1.4	6	7.2.2.1	6	2.3.4.1	30
9.4.2.2	7	9.8.2.2	9	9.1.2.2	6	9.8.1.1	7	9.1.1.1	6	9.1.5.2	4	9.11.1.6	3	9.1.3.2	4	9.1.5.2	4	9.8.3.2	7			9.2.3.6	12		
9.1.3.6	10	9.4.4.2	5			9.1.5.3	6	9.9.5.3	11	9.1.1.2	8	9.2.3.4	9	9.9.3.6	14			9.9.3.2	11			9.9.3.4	11		
	28		30		30		28		30		8		25		24		8		30		8		29		30

Pilot:

A/C:

**G**

← wind/vent **R**

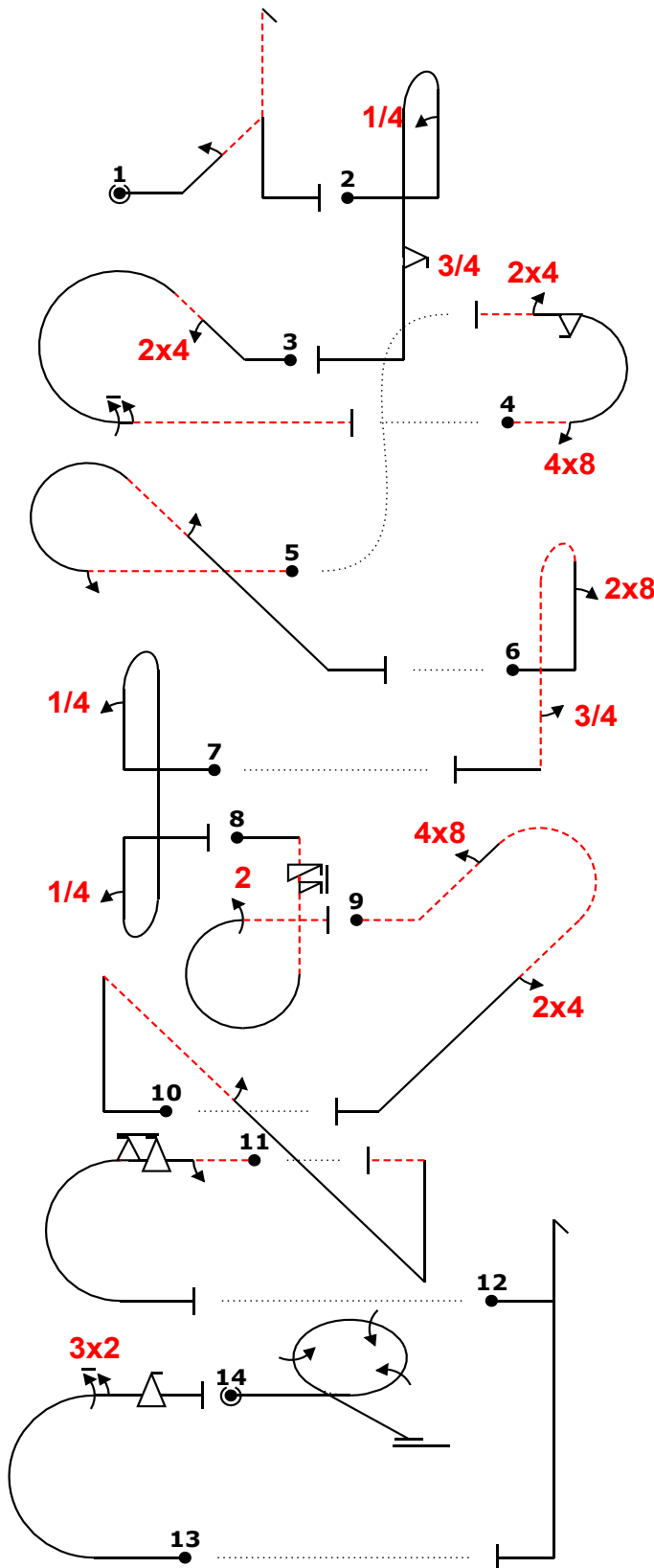

Fig	Grade	Pos	Remarks
1	.		
2	.		
3	.		
4	.		
5	.		
6	.		
7	.		
8	.		
9	.		
10	.		
11	.		
12	.		
13	.		
14	.		

Positioning **30**

Too Low		Trg Violation	
Too High		Wing Rocks	
Interruptions		Disqual Fig	
Insertions		Other(note...)	

"@I" 2dh "@C" 4b. "3f. "@H" 4% "24"rc6- (7,0) "@B" -48m2f,24- (-9,19) "@L" -2c.2.' (5,0) "@J" " " +,8pb.'3 (-13,0) "@L" 4bb(-)4 "@G" 6sirr22- "@F" -48rdb24.....+ (8,0) "@L" n(''2.....)- (-4,0) "@D" 3% -2,6fa (17,0) "@L" "h...." (-18,0) "@A" 5% m32;f+ // "@E" /3j3+ (-3,0) "HUN V1"

Fig 1 I	K	Fig 2 C	K	Fig 3 H	K	Fig 4 B	K	Fig 5 L	K	Fig 6 J	K	Fig 7 L	K	Fig 8 G	K	Fig 9 F	K	Fig 10 L	K	Fig 11 D	K	Fig 12 L	K	Fig 13 A	K	Fig 14 E	K
5.3.2.1	24	8.4.1.1	13	8.5.4.1	11	7.2.3.2	7	8.5.8.2	11	8.4.3.1	15	8.8.2.1	19	8.6.3.3	13	8.4.16.2	16	1.3.11.1	20	7.2.1.4	6	5.2.1.1	17	7.2.2.1	6	2.3.4.1	30
9.1.2.2	6	9.1.1.1	6	9.4.2.2	7	9.8.3.2	7	9.1.3.2	4	9.8.1.1	7	9.1.1.1	6	9.11.1.6	3	9.8.2.2	9	9.1.4.2	4	9.1.3.2	4			9.2.3.6	12		
		9.9.5.3	11	9.1.3.6	10	9.9.3.2	11	9.1.4.2	4	9.1.5.3	6	9.1.1.1	6	9.2.3.4	9	9.4.4.2	5			9.9.3.6	14			9.9.3.4	11		
	<b>30</b>		<b>30</b>		<b>28</b>		<b>30</b>		<b>6</b>		<b>28</b>		<b>6</b>		<b>25</b>		<b>30</b>		<b>6</b>		<b>24</b>		<b>6</b>		<b>29</b>		<b>30</b>

Pilot:

A/C:

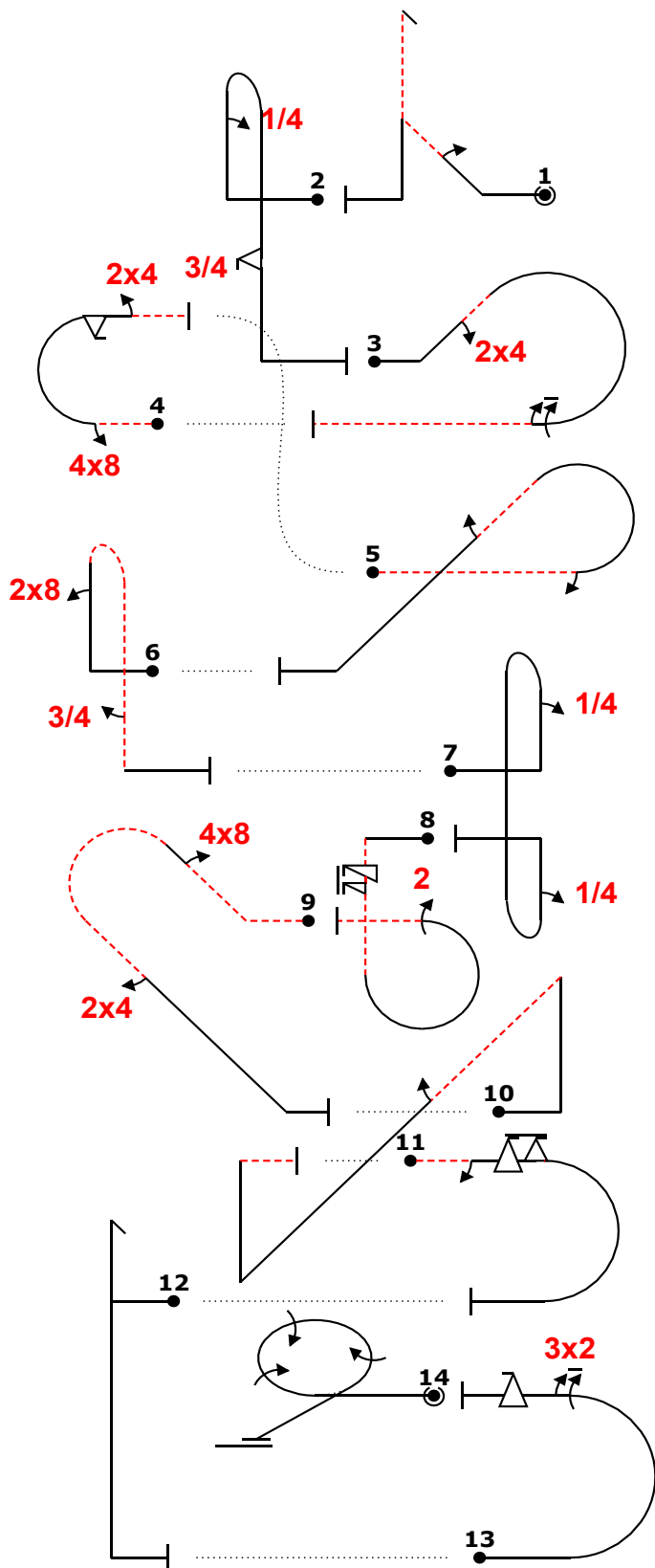
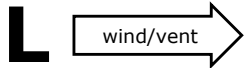

Fig	Grade	Pos	Remarks
1	.		
2	.		
3	.		
4	.		
5	.		
6	.		
7	.		
8	.		
9	.		
10	.		
11	.		
12	.		
13	.		
14	.		

Positioning **30** .

Too Low		Trg Violation	
Too High		Wing Rocks	
Interruptions		Disqual Fig	
Insertions		Other(note...)	

"@I" 2dh "@C" 4b. "13f. "@H" 4% " + "24" rc6- (7,0) "@B" -48m2f,24- (-9,19) "@L" -2c.2.' (5,0) "@J" " +,8pb.'3 (-13,0) "@L" 4bb(-)4 "@G" 6sirr22- "@F" -48rdb24....+ " (-8,0) "@L" n('2.....)' (-4,0) "@D" 3% -2,6fa (17,0) "@L" "h....' (-18,0) "@A" 5% m32;f+ // "@E" /3j3+ (-3,0) "HUN V1"

Fig 1 I	K	Fig 2 C	K	Fig 3 H	K	Fig 4 B	K	Fig 5 L	K	Fig 6 J	K	Fig 7 L	K	Fig 8 G	K	Fig 9 F	K	Fig 10 L	K	Fig 11 D	K	Fig 12 L	K	Fig 13 A	K	Fig 14 E	K
5.3.2.1	24	8.4.1.1	13	8.5.4.1	11	7.2.3.2	7	8.5.8.2	7	8.4.3.1	15	8.8.2.1	19	8.6.3.3	13	8.4.16.2	16	1.3.11.1	20	7.2.1.4	6	5.2.1.1	17	7.2.2.1	6	2.3.4.1	30
9.1.2.2	6	9.1.1.1	6	9.4.2.2	7	9.8.3.2	7	9.1.3.2	4	9.8.1.1	7	9.1.1.1	6	9.1.1.6	3	9.8.2.2	9	9.1.4.2	4	9.1.3.2	4			9.2.3.6	12		
		9.9.5.3	11	9.1.3.6	10	9.9.3.2	11	9.1.4.2	4	9.1.5.3	6	9.1.1.1	6	9.2.3.4	9	9.4.4.2	5			9.9.3.6	14			9.9.3.4	11		
	<b>30</b>		<b>30</b>		<b>28</b>		<b>30</b>		<b>6</b>		<b>28</b>		<b>6</b>		<b>25</b>		<b>30</b>		<b>6</b>		<b>24</b>		<b>6</b>		<b>29</b>		<b>30</b>

**H**

← wind/vent **R**

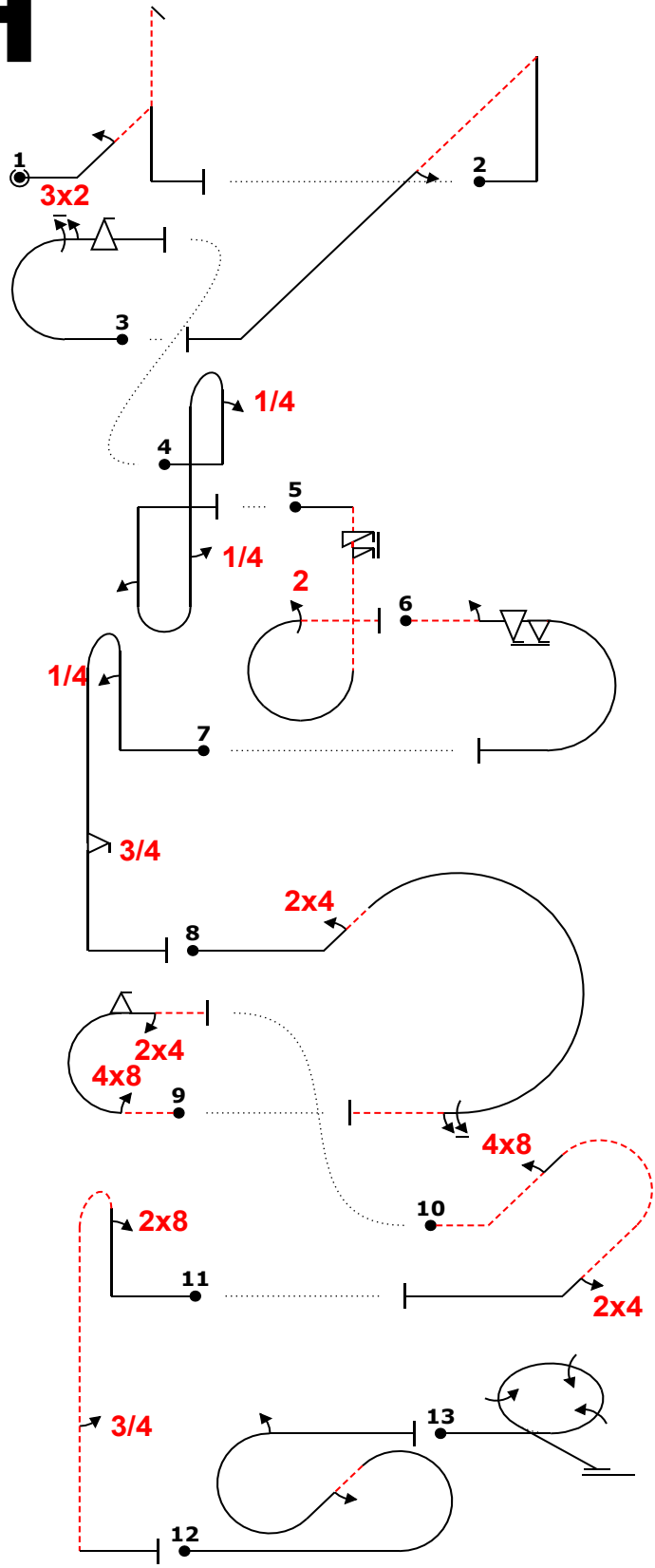

Fig	Grade	Pos	Remarks
1	.		
2	.		
3	.		
4	.		
5	.		
6	.		
7	.		
8	.		
9	.		
10	.		
11	.		
12	.		
13	.		

Positioning **30**

Too Low		Trg Violation	
Too High		Wing Rocks	
Interruptions		Disqual Fig	
Insertions		Other(note...)	

"@I" 2dh (17,0) "@L" k...'2...' (-1,0) "@A" m32;f (-4,18) "@L" '+,4bb('4)2''> (2,0) "@G" 6s.irp22- "@D" 3% - 2,6fa (-17,0) "@C" 4b...'3f..' "@H" 14% '24' 'rc6-' (-9,0) "@B" '-,48m2f,24- (13,17) "@F" -48rd b24 (-12,0) "@J" ,8'pb...'3..' "@L" ac(2)2+' "@E" /3j3~ (5,0) "HUN V2"

Fig 1 I	K	Fig 2 L	K	Fig 3 A	K	Fig 4 L	K	Fig 5 G	K	Fig 6 D	K	Fig 7 C	K	Fig 8 H	K	Fig 9 B	K	Fig 10 F	K	Fig 11 J	K	Fig 12 L	K	Fig 13 E	K
5.3.2.1	24	1.2.7.1	13	7.2.2.1	6	8.8.2.1	19	8.6.3.3	13	7.2.1.4	6	8.4.1.1	13	8.5.4.1	11	7.2.3.2	7	8.4.16.2	16	8.4.3.1	15	7.5.7.1	15	2.3.4.1	30
9.1.2.2	6	9.1.4.2	4	9.2.3.6	12	9.1.1.1	6	9.1.1.6	3	9.1.3.2	4	9.1.1.1	6	9.4.2.2	7	9.8.3.2	7	9.8.2.2	9	9.8.1.1	7	9.1.4.2	4		
				9.9.3.4	11	9.1.5.1	2	9.2.3.4	9	9.9.3.6	14	9.9.5.3	11	9.1.3.6	10	9.9.3.2	11	9.4.4.2	5	9.1.5.3	6	9.1.3.2	4		
						9.1.1.2	8									9.4.3.2	5								
	<b>30</b>		<b>8</b>		<b>29</b>		<b>8</b>		<b>25</b>		<b>24</b>		<b>30</b>		<b>28</b>		<b>30</b>		<b>30</b>		<b>28</b>		<b>8</b>		<b>30</b>

Pilot:

A/C:

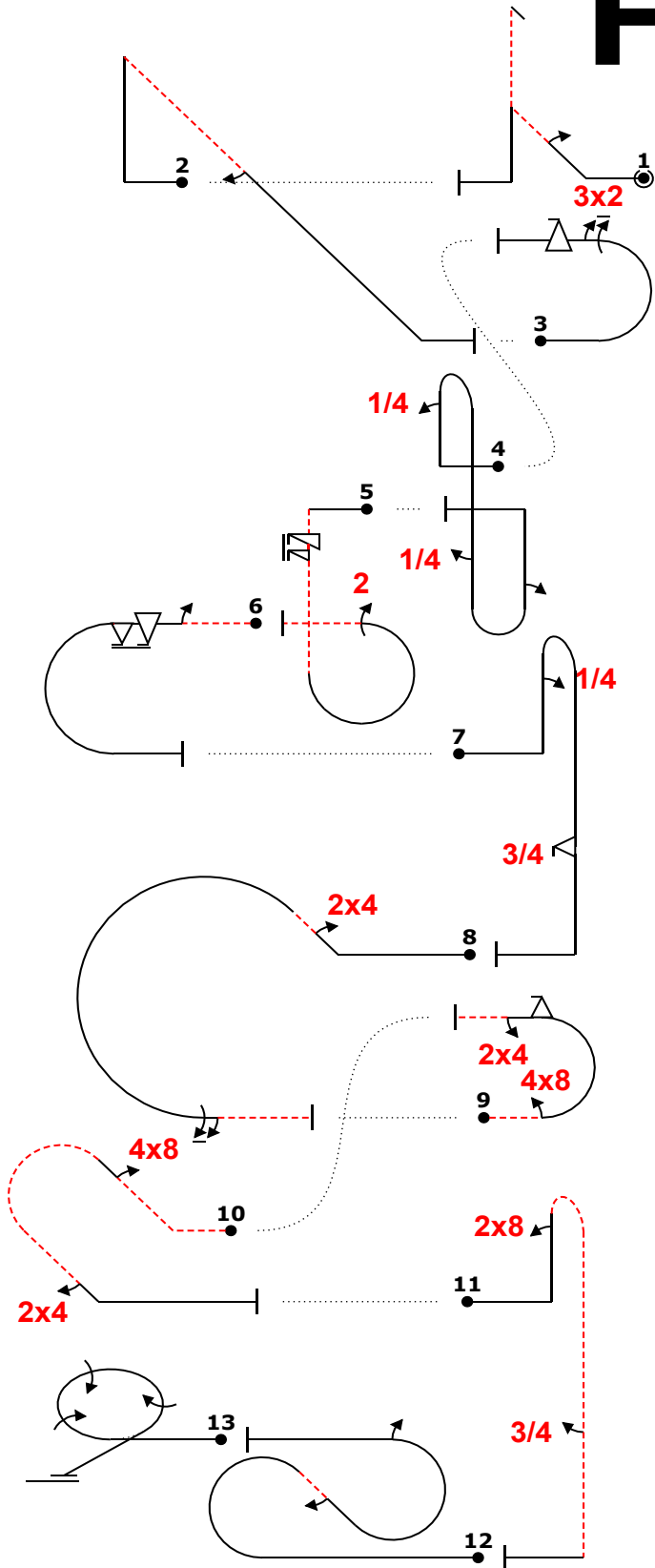
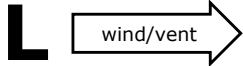

Fig	Grade	Pos	Remarks
1	.		
2	.		
3	.		
4	.		
5	.		
6	.		
7	.		
8	.		
9	.		
10	.		
11	.		
12	.		
13	.		

Positioning	30
-------------	----

Too Low		Trg Violation	
Too High		Wing Rocks	
Interruptions		Disqual Fig	
Insertions		Other(note...)	

"@I" 2dh (17,0) "@L" k.'2... (-1,0) "@A" m32;f (-4,18) "@L" +,4bb('4)2' > (2,0) "@G" 6s.irp22- "@D" 3% - 2,6fa (-17,0) "@C" 4b...'3f.' "@H" 14% ~~~~~ 24 ~~~~~ rnc6- ~~~~~ (-9,0) "@B" -,48m2f,24- (13,17) "@F" -48rd b24 (-12,0) "@J" ,8`pb...'3.. "@L" ac(2)2+ ~~~~~ "@E" /3j3~ (5,0) "HUN V2"

Fig 1 I	K	Fig 2 L	K	Fig 3 A	K	Fig 4 L	K	Fig 5 G	K	Fig 6 D	K	Fig 7 C	K	Fig 8 H	K	Fig 9 B	K	Fig 10 F	K	Fig 11 J	K	Fig 12 L	K	Fig 13 E	K
5.3.2.1	24	1.2.7.1	13	7.2.2.1	6	8.8.2.1	19	8.6.3.3	13	7.2.1.4	6	8.4.1.1	13	8.5.4.1	11	7.2.3.2	7	8.4.3.1	15	7.5.7.1	15	2.3.4.1	30		
9.1.1.2	6	9.1.4.2	4	9.2.3.6	12	9.1.1.1	6	9.1.1.6	3	9.1.3.2	4	9.1.1.1	6	9.4.2.2	7	9.8.3.2	7	9.8.2.2	9	9.8.1.1	7	9.1.4.2	4		
				9.9.3.4	11	9.1.5.1	2	9.2.3.4	9	9.9.3.6	14	9.9.5.3	11	9.1.3.6	10	9.9.3.2	11	9.4.4.2	5	9.1.5.3	6	9.1.3.2	4		
				9.1.1.2	8											9.4.3.2	5								
	<b>30</b>		<b>8</b>		<b>29</b>		<b>8</b>		<b>25</b>		<b>24</b>		<b>30</b>		<b>28</b>		<b>30</b>		<b>30</b>		<b>28</b>		<b>8</b>		<b>30</b>

Pilot:

A/C:



**I** ← wind/vent **R**

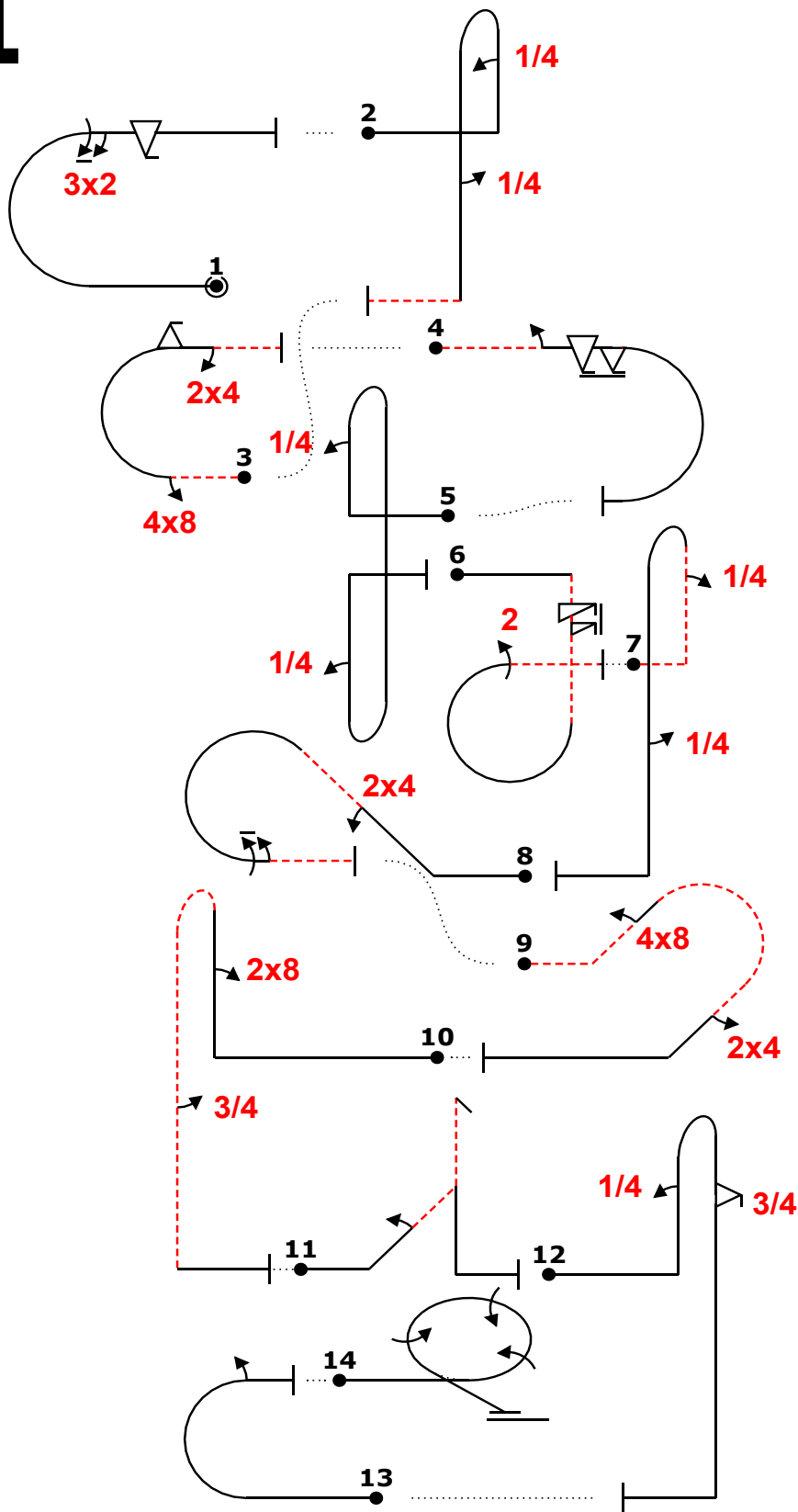

Fig	Grade	Pos	Remarks
1	.		
2	.		
3	.		
4	.		
5	.		
6	.		
7	.		
8	.		
9	.		
10	.		
11	.		
12	.		
13	.		
14	.		

Positioning

30

.

Too Low

Trg Violation

Too High

Wing Rocks

Interruptions

Disqual Fig

Insertions

Other(note...)

ed "@A" 3% 'm,32;f~ (2,0) "@L" ~~~|"4b.4.' (-4,12) "@B" 1% -48m2f,24- (6,0) "@D" 3% -'2,6fa+~ (-6,1) "@L" 4bb(..)'4'+' "@G" +6sirp22- (-2,0) "@L" ~~~,4b..4.' "@H" 1% ~~~|"24'rc6-~ (7,7) "@F" ~~~|"48rd b``24' (1,0) "@J" ~~~,8'pb..3.. (-2,0) "@I" 2dh(~) "@C" ~4b``3f.....^ (-12,0) "@L" .m2+ (-1,0) "@E" /3j3

Fig 1 A	K	Fig 2 L	K	Fig 3 B	K	Fig 4 D	K	Fig 5 L	K	Fig 6 G	K	Fig 7 L	K	Fig 8 H	K	Fig 9 F	K	Fig 10 J	K	Fig 11 I	K	Fig 12 C	K	Fig 13 L	K	Fig 14 E	K
7.2.2.1	6	8.4.2.1	14	7.2.3.2	7	7.2.1.4	6	8.8.2.1	19	8.6.3.3	13	8.4.4.2	14	8.5.4.1	11	8.4.16.2	16	8.4.3.1	15	5.3.2.1	24	8.4.1.1	13	7.2.2.1	6	2.3.4.1	30
9.2.3.6	12	9.1.1.1	6	9.8.3.2	7	9.1.3.2	4	9.1.1.1	6	9.11.1.6	3	9.1.1.1	6	9.4.2.2	7	9.8.2.2	9	9.8.1.1	7	9.1.2.2	6	9.1.1.1	6	9.1.3.2	4		
9.9.3.4	11	9.1.5.1	2	9.9.3.2	11	9.9.3.6	14	9.1.1.1	6	9.2.3.4	9	9.1.5.1	2	9.1.3.6	10	9.4.4.2	5	9.1.5.3	6			9.9.5.3	11				
	29		6		30		24		6		25		6		28		30		28		30		30		6		30

Pilot:

A/C:

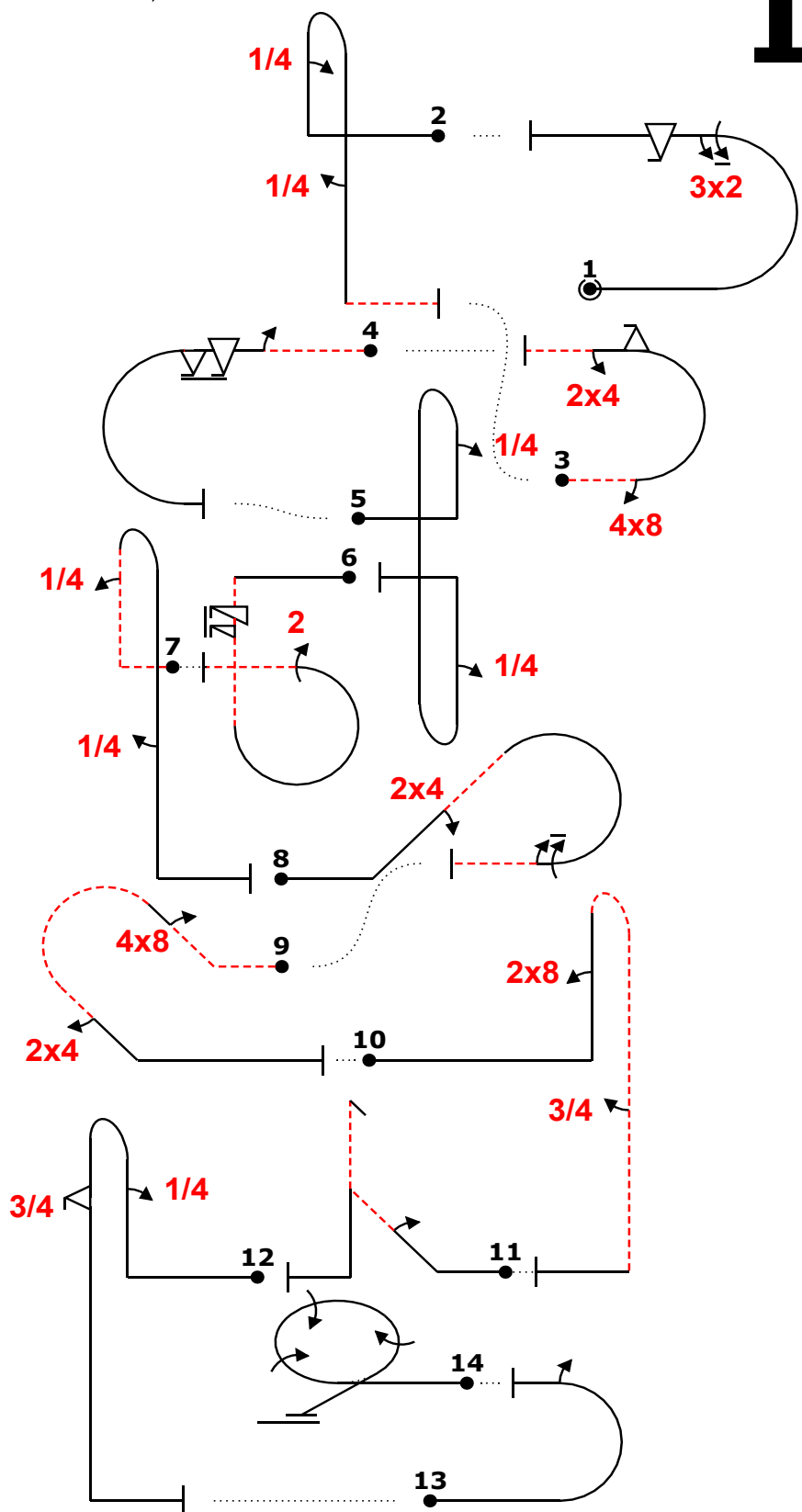
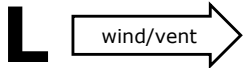

Fig	Grade	Pos	Remarks
1	.		
2	.		
3	.		
4	.		
5	.		
6	.		
7	.		
8	.		
9	.		
10	.		
11	.		
12	.		
13	.		
14	.		

Positioning	30	.
-------------	----	---

Too Low		Trg Violation	
Too High		Wing Rocks	
Interruptions		Disqual Fig	
Insertions		Other(note...)	

ed "@A" 3% 'm,32;f~ (2,0) "@L" ~~~~~|"4b.4.' (-4,12) "@B" 1% -48m2f,24- (6,0) "@D" 3% -'2,6fa+'' (-6,1) "@L" 4bb(..)'4''+' "@G" +6sirr22- (-2,0) "@L" ~~~~~,4b..4.' "H" 1% ~~~~~|"24'rc6-~~~~~ (7,7) "@F" ~~~~~|"48rd b''24'' (1,0) "@J" ~~~+,8''pb..3..' (-2,0) "@I" 2dh(()) "@C" ~4b''3f.....'^ (-12,0) "@L" .''m2+ (-1,0) "@E" /3j3

Fig 1 A	K	Fig 2 L	K	Fig 3 B	K	Fig 4 D	K	Fig 5 L	K	Fig 6 G	K	Fig 7 L	K	Fig 8 H	K	Fig 9 F	K	Fig 10 J	K	Fig 11 I	K	Fig 12 C	K	Fig 13 L	K	Fig 14 E	K
7.2.2.1	6	8.4.2.1	14	7.2.3.2	7	7.2.1.4	6	8.8.2.1	19	8.6.3.3	13	8.4.4.2	14	8.5.4.1	11	8.4.16.2	16	8.4.3.1	15	5.3.2.1	24	8.4.1.1	13	7.2.2.1	6	2.3.4.1	30
9.2.3.6	12	9.1.1.1	6	9.8.3.2	7	9.1.3.2	4	9.1.1.1	6	9.11.1.6	3	9.1.1.1	6	9.4.2.2	7	9.8.2.2	9	9.8.1.1	7	9.1.2.2	6	9.1.1.1	6	9.1.3.2	4		
9.9.3.4	11	9.1.5.1	2	9.9.3.2	11	9.9.3.6	14	9.1.1.1	6	9.2.3.4	9	9.1.5.1	2	9.1.3.6	10	9.4.4.2	5	9.1.5.3	6			9.9.5.3	11				
	29		6		30		24		6		25		6		28		30		28		30		30		6		30

Pilot:

A/C:

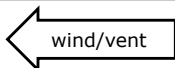

**R**

**J**

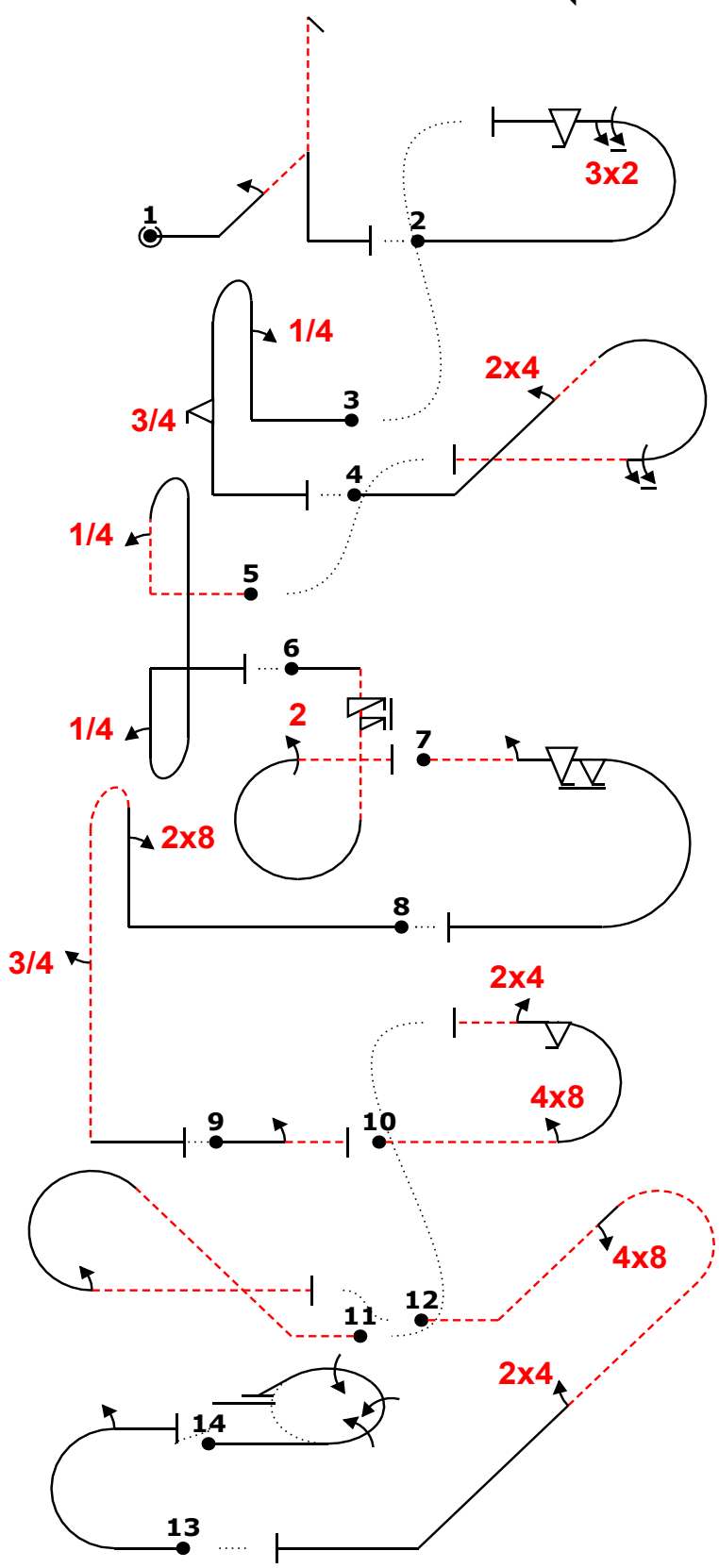

Fig	Grade	Pos	Remarks
1	.		
2	.		
3	.		
4	.		
5	.		
6	.		
7	.		
8	.		
9	.		
10	.		
11	.		
12	.		
13	.		
14	.		

Positioning	30	.
-------------	----	---

Too Low		Trg Violation	
Too High		Wing Rocks	
Interruptions		Disqual Fig	
Insertions		Other(note...)	

"@I" 2dh(') (-1,0) "@A" ... 'm32;f (-5,20) "@C" ,4b,3f' (-1,0) "@H" ~~~24rc6~' (-9,9) "@L" -'4bb(')4 (-1,0) "@G" 6sirp22- "@D" 4% -2,6fa+ (1,0) "@J" ~~~+,8pb.,3... ' (-2,0) "@L" 2- "@B" ~.. '48m2f,24- (-2,21) "@L" -rc2- (3 ,2) "@F" -1% ~.. ,48rdb... ,24....+' (-2,0) "@L" m2 (-2,1) "@E" -1% 3j3+~'~'~'

Fig 1 I	K	Fig 2 A	K	Fig 3 C	K	Fig 4 H	K	Fig 5 L	K	Fig 6 G	K	Fig 7 D	K	Fig 8 J	K	Fig 9 L	K	Fig 10 B	K	Fig 11 L	K	Fig 12 F	K	Fig 13 L	K	Fig 14 E	K
5.3.2.1	24	7.2.2.1	6	8.4.1.1	13	8.5.4.1	11	8.8.7.2	21	8.6.3.3	13	7.2.1.4	6	8.4.3.1	15	1.1.1.3	2	7.2.3.2	7	8.5.3.2	11	8.4.16.2	16	7.2.2.1	6	2.3.4.1	30
9.1.2.2	6	9.2.3.6	12	9.1.1.1	6	9.4.2.2	7	9.1.1.1	6	9.11.1.6	3	9.1.3.2	4	9.8.1.1	7	9.1.3.2	4	9.8.3.2	7	9.1.3.2	4	9.8.2.2	9	9.1.3.2	4		
		9.9.3.4	11	9.9.5.3	11	9.1.3.6	10	9.1.1.1	6	9.2.3.4	9	9.9.3.6	14	9.1.5.3	6			9.9.3.2	11			9.4.4.2	5				
																		9.4.3.2	5								
	30		29		30		28		6		25		24		28		6		30		6		30		6	30	

Pilot:

A/C:

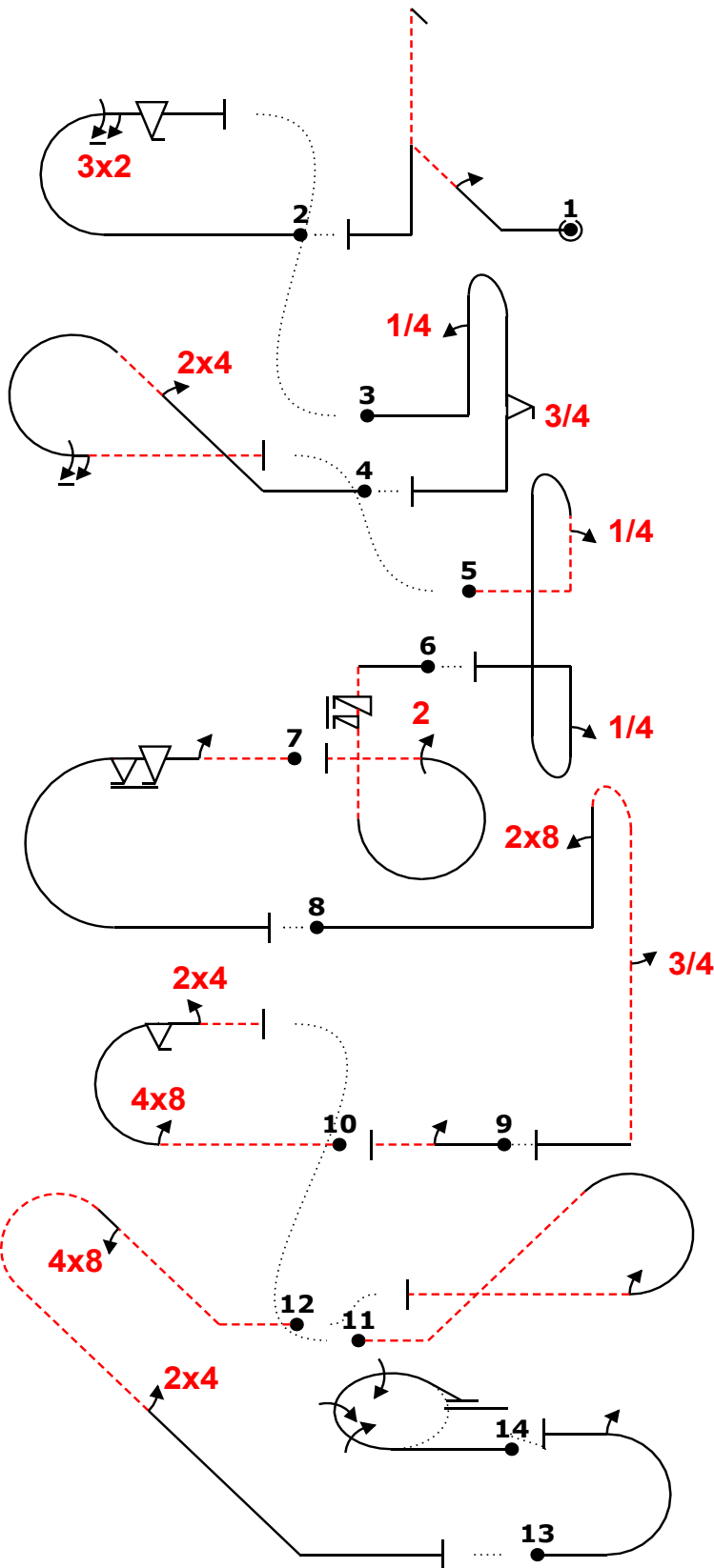
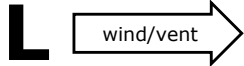

Fig	Grade	Pos	Remarks
1	.		
2	.		
3	.		
4	.		
5	.		
6	.		
7	.		
8	.		
9	.		
10	.		
11	.		
12	.		
13	.		
14	.		

Positioning  
**30** .

Too Low		Trg Violation	
Too High		Wing Rocks	
Interruptions		Disqual Fig	
Insertions		Other(note...)	

"@I" 2dh(') (-1,0) "@A" ...'m32;f (-5,20) "@C" ,4b,3f' (-1,0) "@H" ~24rc6-' (-9,9) "@L" -'4bb(')4 (-1,0) "  
 @G" 6sirp22- "@D" 4% -2,6fa+ (1,0) "@J" ~+++,8pb.,3...' (-2,0) "@L" 2- "@B" -...'48m2f,24- (-2,21) "@L" -rc2- (3  
 ,2) "@F" -1% --',48rdb...'24.....+' (-2,0) "@L" m2 (-2,1) "@E" -1% 3j3+''''

Fig 1 I	K	Fig 2 A	K	Fig 3 C	K	Fig 4 H	K	Fig 5 L	K	Fig 6 G	K	Fig 7 D	K	Fig 8 J	K	Fig 9 L	K	Fig 10 B	K	Fig 11 L	K	Fig 12 F	K	Fig 13 L	K	Fig 14 E	K
5.3.2.1	24	7.2.2.1	6	8.4.1.1	13	8.5.4.1	11	8.8.7.2	21	8.6.3.3	13	7.2.1.4	6	8.4.3.1	15	1.1.1.3	2	7.2.3.2	7	8.5.3.2	11	8.4.16.2	16	7.2.2.1	6	2.3.4.1	30
9.1.2.2	6	9.2.3.6	12	9.1.1.1	6	9.4.2.2	7	9.1.1.1	6	9.11.1.6	3	9.1.3.2	4	9.8.1.1	7	9.1.3.2	4	9.8.3.2	7	9.1.3.2	4	9.8.2.2	9	9.1.3.2	4		
		9.9.3.4	11	9.9.5.3	11	9.1.3.6	10	9.1.1.1	6	9.2.3.4	9	9.9.3.6	14	9.1.5.3	6			9.9.3.2	11			9.4.4.2	5				
																		9.4.3.2	5								
	<b>30</b>		<b>29</b>		<b>30</b>		<b>28</b>		<b>6</b>		<b>25</b>		<b>24</b>		<b>28</b>		<b>6</b>		<b>30</b>		<b>6</b>		<b>30</b>		<b>6</b>		<b>30</b>

Pilot:

A/C: