

A ← wind/vent **R**

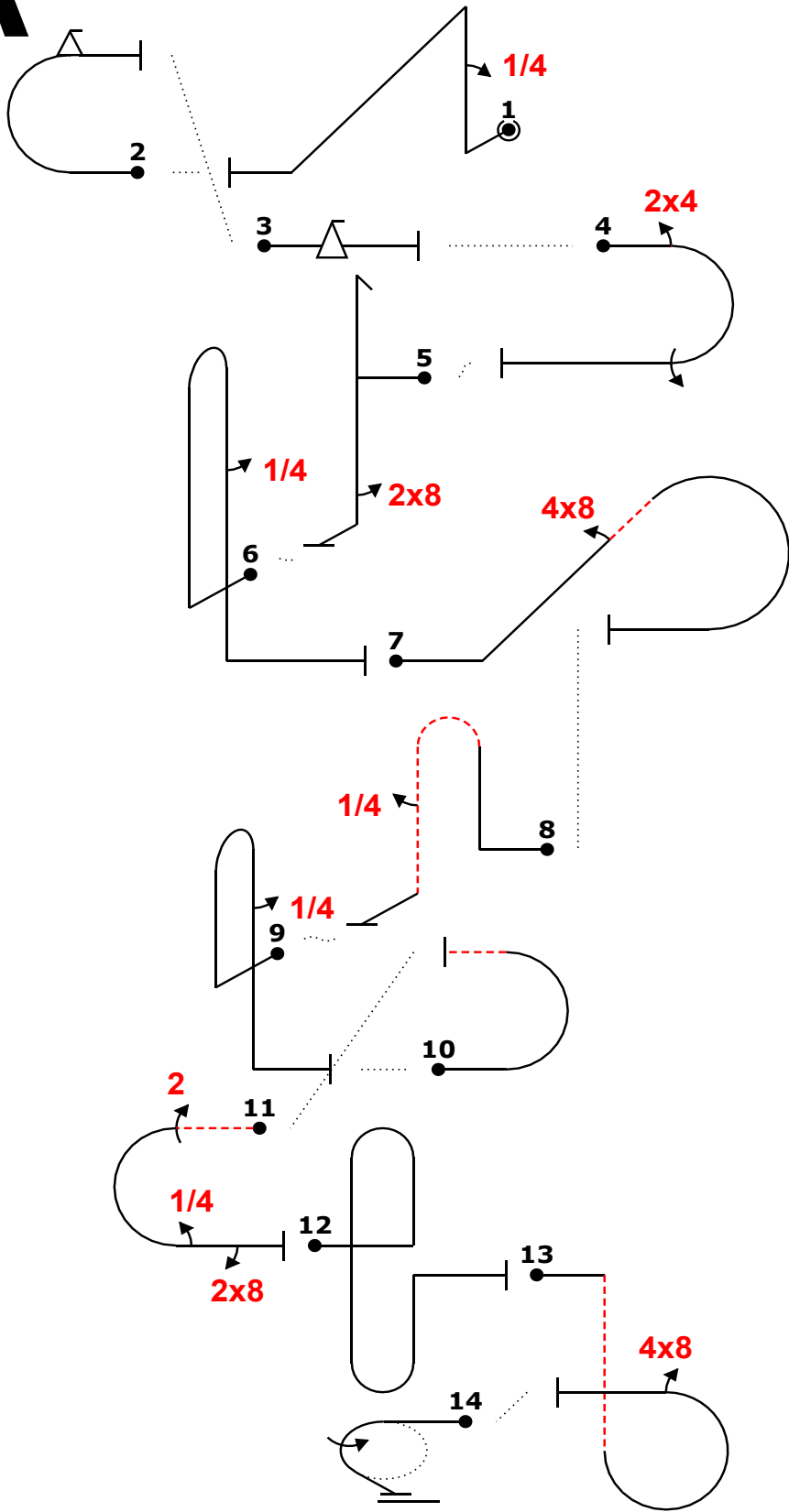

Fig	Grade	Pos	Remarks
1	.		
2	.		
3	.		
4	.		
5	.		
6	.		
7	.		
8	.		
9	.		
10	.		
11	.		
12	.		
13	.		
14	.		

Positioning
30 .

Too Low		Trg Violation	
Too High		Wing Rocks	
Interruptions		Disqual Fig	
Insertions		Other(note...)	

ej "@E" ,4k> (-2,0) "@A" m2f [4,13] "@H" f~ (8,0) "@C" 24a1+~ (-1,1) "@D" `h.'8 (-1,0) "@L" ..'b'4...+ 3% "@I" " `48`rc+~ [0,15] "@J" `+`pb` ,4'' (-2,0) "@L" b`'4...+ (3,0) "@L" m- [-8,12] "@F" -',22a'4'',8+` "@L" bb"@B" irp,48~ [-2,2] -3% "@G" /-1j1

Fig 1 E	K	Fig 2 A	K	Fig 3 H	K	Fig 4 C	K	Fig 5 D	K	Fig 6 L	K	Fig 7 I	K	Fig 8 J	K	Fig 9 L	K	Fig 10 L	K	Fig 11 F	K	Fig 12 L	K	Fig 13 B	K	Fig 14 G	K
1.2.6.1	14	7.2.2.1	6	1.1.1.1	2	7.2.3.3	6	5.2.1.1	17	8.4.1.1	13	8.5.2.1	10	8.4.3.1	15	8.4.1.1	13	7.2.1.1	6	7.2.1.4	6	8.8.2.1	19	8.6.4.3	13	2.1.3.1	14
9.1.1.1	6	9.9.3.2	11	9.9.3.4	11	9.4.3.2	5	9.8.5.1	3	9.1.5.1	2	9.8.2.2	9	9.1.5.1	2	9.1.5.1	2			9.2.3.4	9			9.8.3.2	7		
	20		17		13	9.1.3.4	8		20		6		19		17		6	6		20		6		20		14	

Pilot:

A/C:



Figure K
203
Total K
233

Judges Name	
Signature	Number

Flight #

L wind/vent →

A

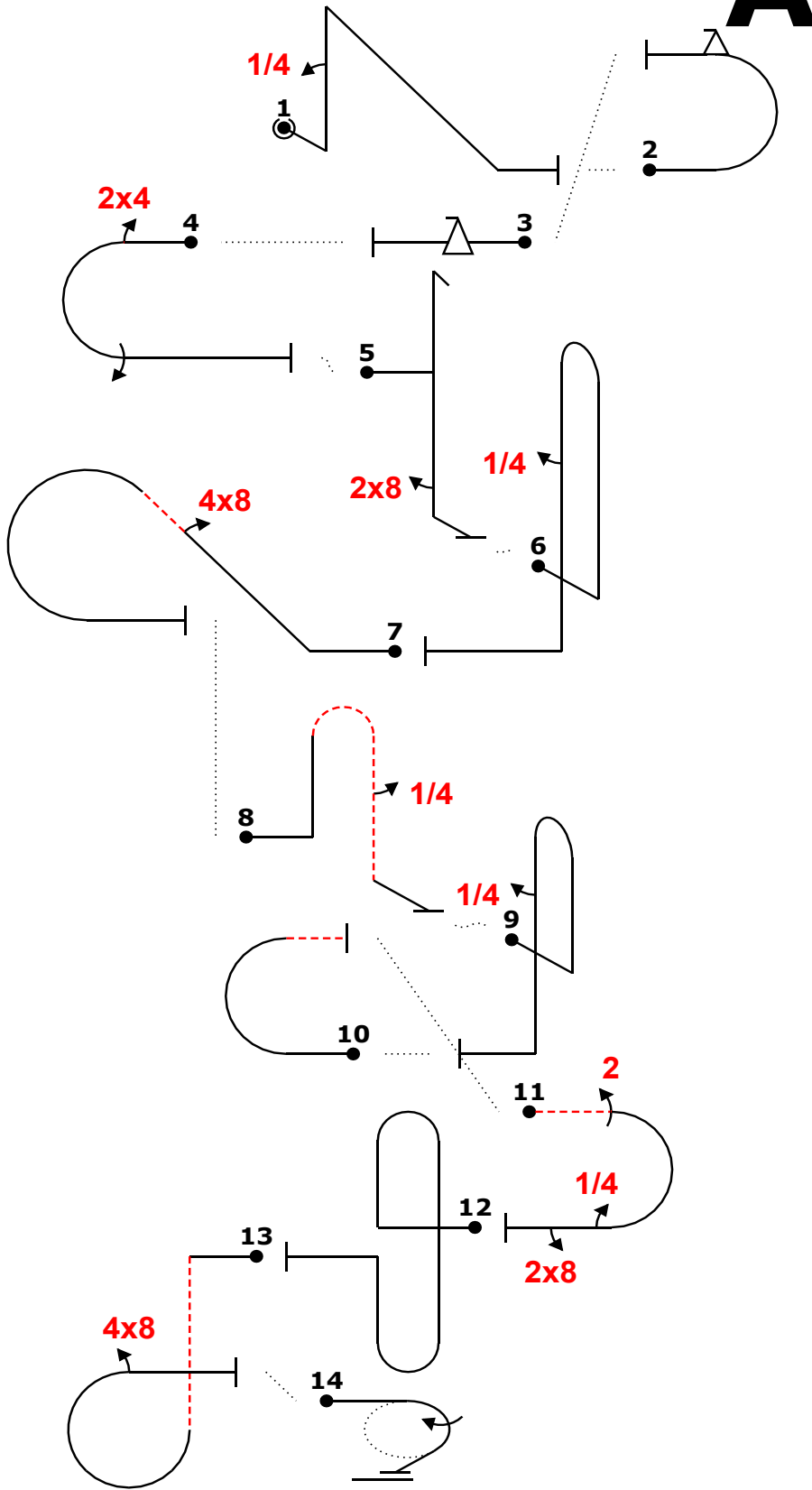

Fig	Grade	Pos	Remarks
1	.		
2	.		
3	.		
4	.		
5	.		
6	.		
7	.		
8	.		
9	.		
10	.		
11	.		
12	.		
13	.		
14	.		

Positioning

Too Low	<input type="text"/>	Trg Violation	<input type="text"/>
Too High	<input type="text"/>	Wing Rocks	<input type="text"/>
Interruptions	<input type="text"/>	Disqual Fig	<input type="text"/>
Insertions	<input type="text"/>	Other(note...)	<input type="text"/>

ej "@E",4k> (-2,0) "@A" m2f [4,13] "@H" f~ (8,0) "@C" 24a1++~ (-1,1) "@D" `h.'8 (-1,0) "@L" ..'b'4...+ 3% "@I
" `48`rc+~~~~~ [0,15] "@J" `+`pb`',4'' (-2,0) "@L" b`'4...'+ (3,0) "@L" m- [-8,12] "@F" '-',22a'4'',8+`"@
L" bb"@B" irp,48~ [-2,2] -3% "@G" /-1j1

Fig	E	K	Fig	2 A	K	Fig	3 H	K	Fig	4 C	K	Fig	5 D	K	Fig	6 L	K	Fig	7 I	K	Fig	8 J	K	Fig	9 L	K	Fig	10 L	K	Fig	11 F	K	Fig	12 L	K	Fig	13 B	K	Fig	14 G	K
1.2.6.1	14	7.2.2.1	6	1.1.1.1	2	7.2.3.3	6	5.2.1.1	17	8.4.1.1	13	8.5.2.1	10	8.4.3.1	15	8.4.1.1	13	7.2.1.1	6	7.2.1.4	6	8.8.2.1	19	8.6.4.3	13	2.1.3.1	14														
9.1.1.1	6	9.9.3.2	11	9.9.3.4	11	9.4.3.2	5	9.8.5.1	3	9.1.5.1	2	9.8.2.2	9	9.1.5.1	2	9.1.5.1	2			9.2.3.4	9			9.8.3.2	7																
	20		17		13		19		20		6		19		17		6			9.1.3.1	2																				
																				9.8.3.1	3																				
																					20		6		20																

Pilot:

A/C:

B

wind/vent ← **R**

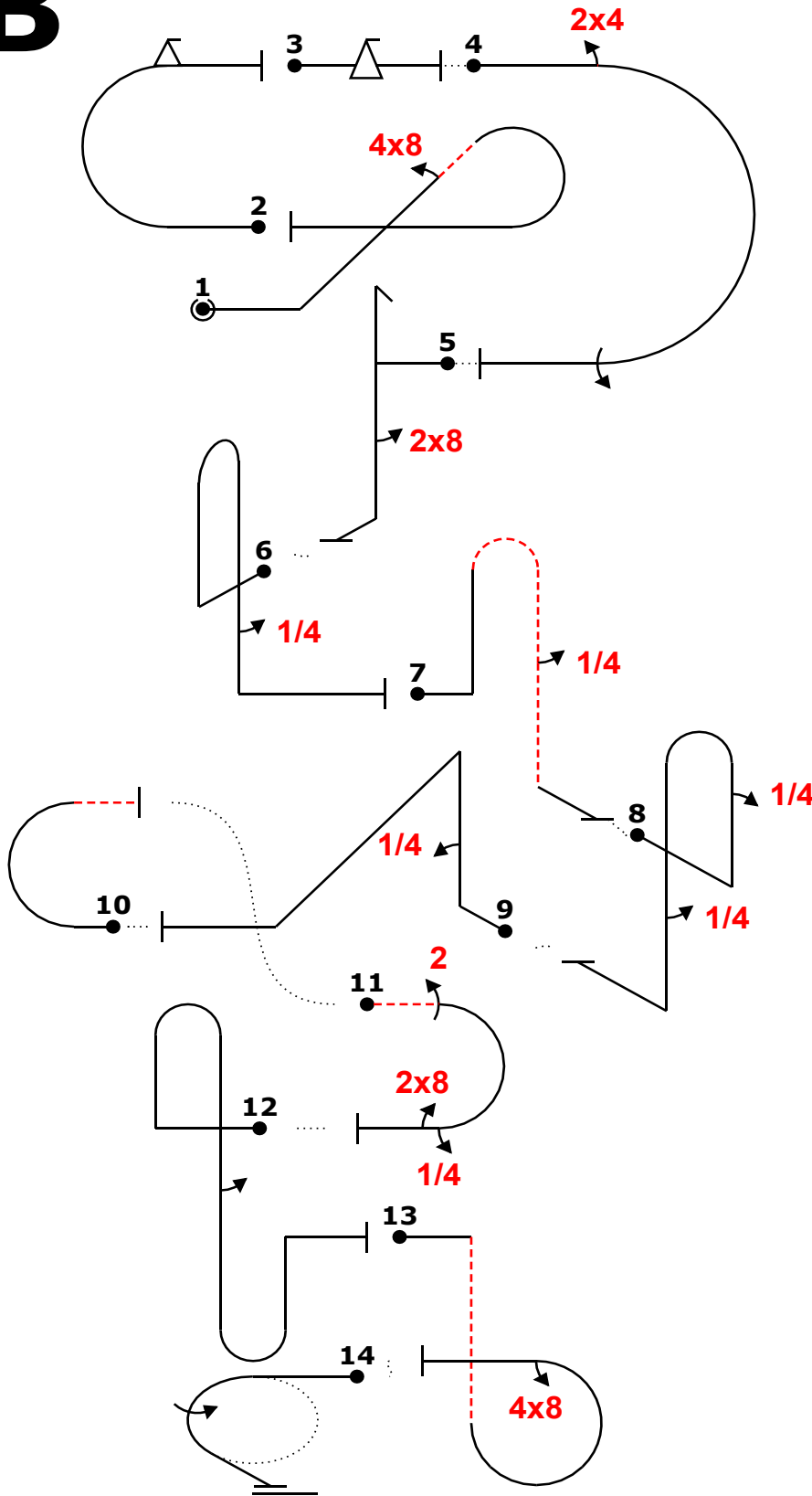

Fig	Grade	Pos	Remarks
1	.		
2	.		
3	.		
4	.		
5	.		
6	.		
7	.		
8	.		
9	.		
10	.		
11	.		
12	.		
13	.		
14	.		

Positioning **30** .

Too Low		Trg Violation	
Too High		Wing Rocks	
Interruptions		Disqual Fig	
Insertions		Other(note...)	

-2% "@I" +.'48rc+ 3% "@A" m2f "@H" f (-2,0) 14% "@C" `24a1+' (2,0) "@D" ``h'8. (-1,0) "@L" b.'4+ "@J" /'``+ pb4.' (-1,-1) "@L" +,4b.'4'+ (-1,0) "@E" ``4''k+> (1,0) "@L" ``m- (10,13) "@F" -22a4,8 (-2,0) "@L" bb(2.'')+" "@B" irp48~ (0,1) "@G" 1j1

Fig 1 I	K	Fig 2 A	K	Fig 3 H	K	Fig 4 C	K	Fig 5 D	K	Fig 6 L	K	Fig 7 J	K	Fig 8 L	K	Fig 9 E	K	Fig 10 L	K	Fig 11 F	K	Fig 12 L	K	Fig 13 B	K	Fig 14 G	K
8.5.2.1	10	7.2.2.1	6	1.1.1.1	2	7.2.3.3	6	5.2.1.1	17	8.4.1.1	13	8.4.3.1	15	8.4.1.1	13	1.2.6.1	14	7.2.1.1	6	7.2.1.4	6	8.8.2.1	19	8.6.4.3	13	2.1.3.1	14
9.8.2.2	9	9.9.3.2	11	9.9.3.4	11	9.4.3.2	5	9.8.5.1	3	9.1.5.1	2	9.1.5.1	2	9.1.1.1	6	9.1.1.1	6			9.2.3.4	9	9.1.5.2	4	9.8.3.2	7		
						9.1.3.4	8							9.1.5.1	2					9.1.3.1	2						
																				9.8.3.1	3						
	19		17		13		19		20		6		17		6		20		6		20		6		20	14	

Pilot:

A/C:

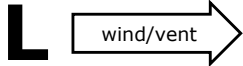

B

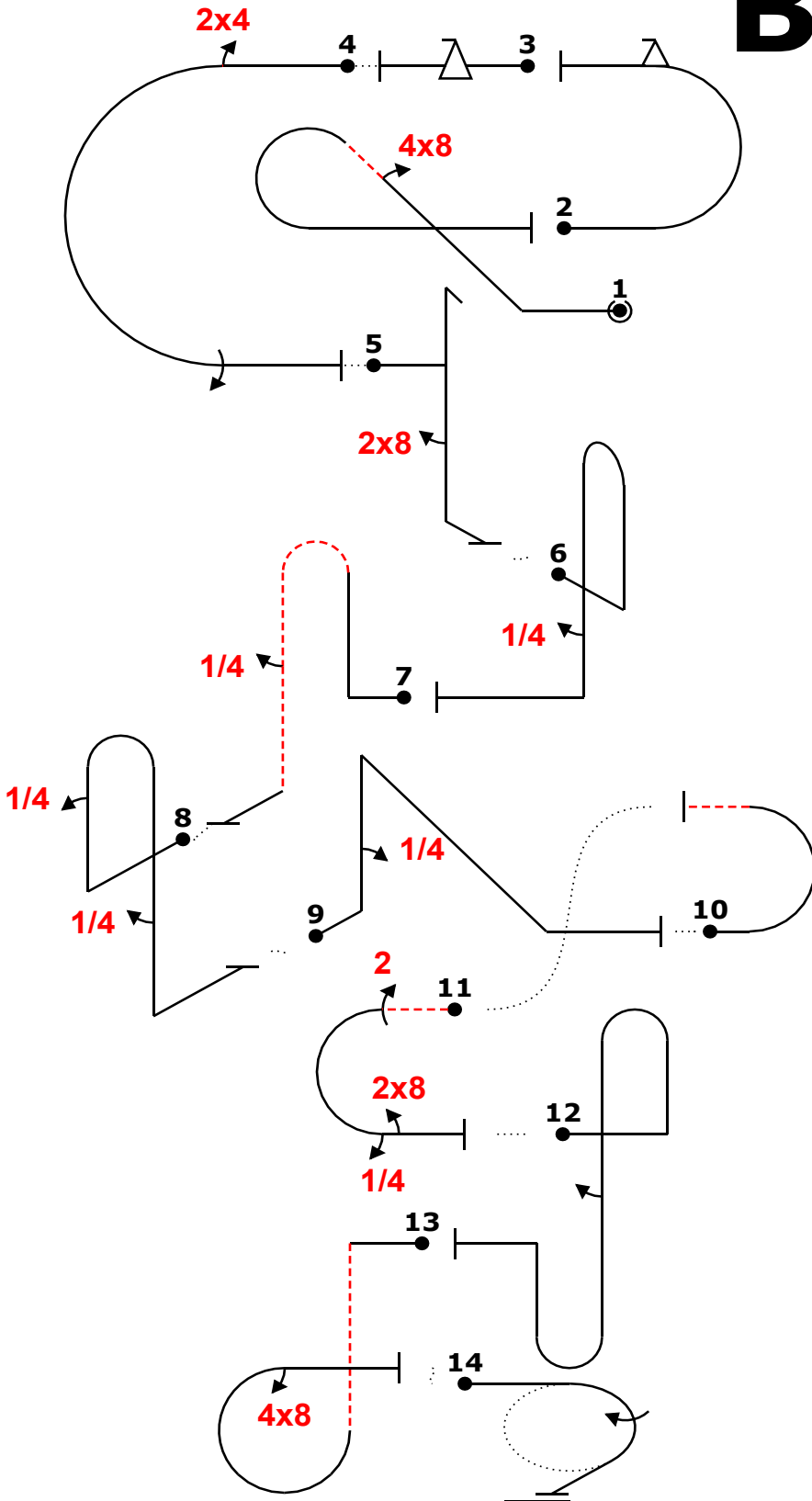

Fig	Grade	Pos	Remarks
1	.		
2	.		
3	.		
4	.		
5	.		
6	.		
7	.		
8	.		
9	.		
10	.		
11	.		
12	.		
13	.		
14	.		

Positioning
 30

Too Low		Trg Violation	
Too High		Wing Rocks	
Interruptions		Disqual Fig	
Insertions		Other(note...)	

-2% "@I" +. '48rc+ 3% "@A" m2f "@H" f (-2,0) 14% "@C" `24a1+' (2,0) "@D" ``h'8. (-1,0) "@L" b.'4+ "@J" /'``+ pb4.' (-1,-1) "@L" +,4b.'4''+ (-1,0) "@E" ``4''k+> (1,0) "@L" ``m- (10,13) "@F" -22a4,8 (-2,0) "@L" bb(2.'')+" "@B" irp48~ (0,1) "@G" 1j1

Fig 1 I	K	Fig 2 A	K	Fig 3 H	K	Fig 4 C	K	Fig 5 D	K	Fig 6 L	K	Fig 7 J	K	Fig 8 L	K	Fig 9 E	K	Fig 10 L	K	Fig 11 F	K	Fig 12 L	K	Fig 13 B	K	Fig 14 G	K
8.5.2.1	10	7.2.2.1	6	1.1.1.1	2	7.2.3.3	6	5.2.1.1	17	8.4.1.1	13	8.4.3.1	15	8.4.1.1	13	1.2.6.1	14	7.2.1.1	6	7.2.1.4	6	8.8.2.1	19	8.6.4.3	13	2.1.3.1	14
9.8.2.2	9	9.9.3.2	11	9.9.3.4	11	9.4.3.2	5	9.8.5.1	3	9.1.5.1	2	9.1.5.1	2	9.1.1.1	6	9.1.1.1	6			9.2.3.4	9	9.1.5.2	4	9.8.3.2	7		
						9.1.3.4	8							9.1.5.1	2					9.1.3.1	2						
	19		17		13		19		20		6		17		6		20	6		20		6		20		14	

Pilot:

A/C:

C

wind/vent ← **R**

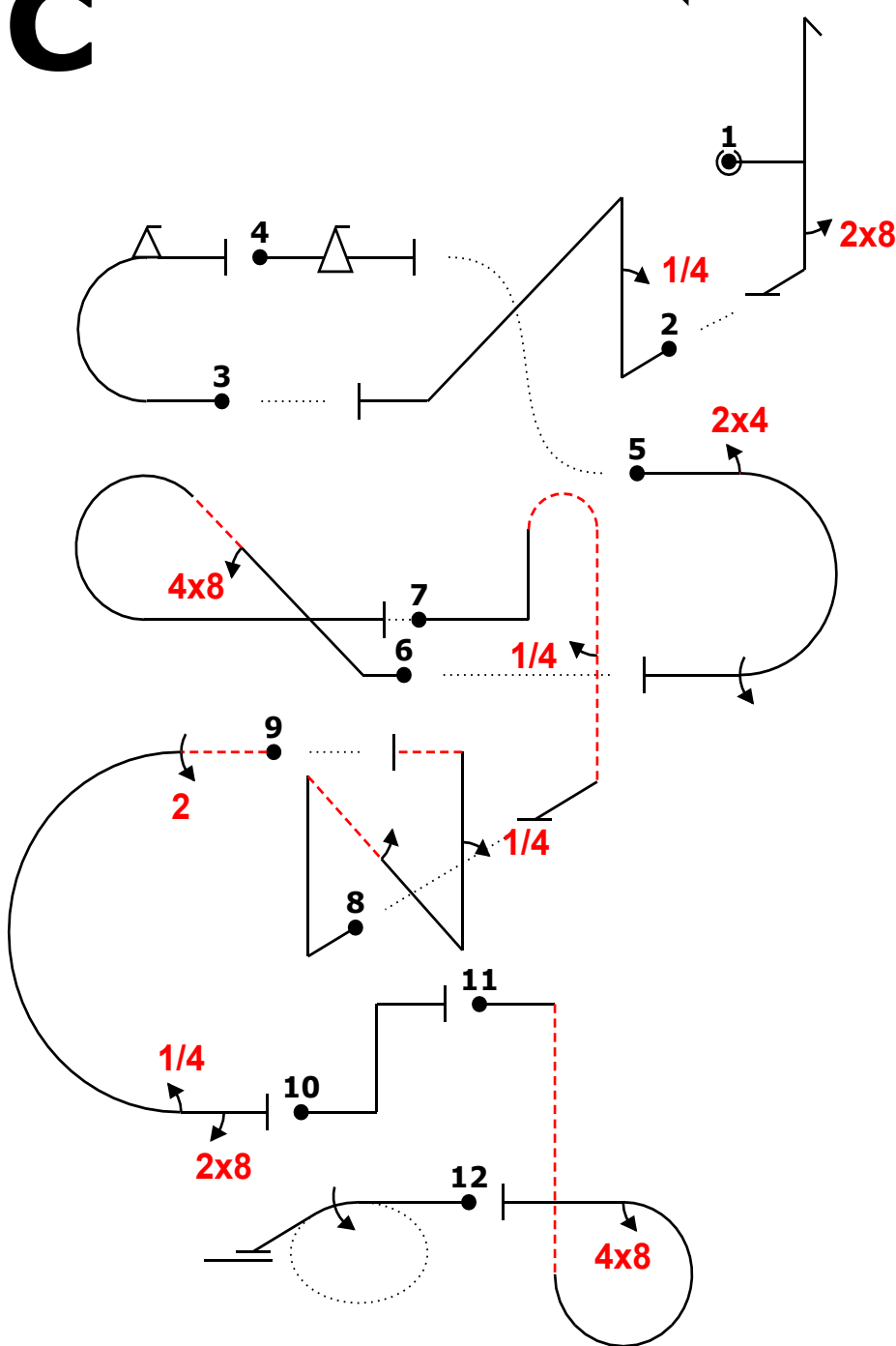

Fig	Grade	Pos	Remarks
1	.		
2	.		
3	.		
4	.		
5	.		
6	.		
7	.		
8	.		
9	.		
10	.		
11	.		
12	.		

Positioning **30** .

Too Low		Trg Violation	
Too High		Wing Rocks	
Interruptions		Disqual Fig	
Insertions		Other(note...)	

"@D" h8 (-2,1) "@E" ,4k (-4,0) "@A" m2f "@H" f (9,12) 4% "@C" 24a1 (-10,0) "@I" ``+48rc (-2,0) "@J" ``pb',4. (-7,4) "@L" n(''2..'),4'- (-3,0) 15% "@F" -'22a4,8+' "@L" v' "@B" .irp48- "@G" 1j1

Fig 1 D	K	Fig 2 E	K	Fig 3 A	K	Fig 4 H	K	Fig 5 C	K	Fig 6 I	K	Fig 7 J	K	Fig 8 L	K	Fig 9 F	K	Fig 10 L	K	Fig 11 B	K	Fig 12 G	K
5.2.1.1	17	1.2.6.1	14	7.2.2.1	6	1.1.1.1	2	7.2.3.3	6	8.5.2.1	10	8.4.3.1	15	1.3.11.1	20	7.2.1.4	6	1.1.6.1	10	8.6.4.3	13	2.1.3.1	14
9.8.5.1	3	9.1.1.1	6	9.9.3.2	11	9.9.3.4	11	9.4.3.2	5	9.8.2.2	9	9.1.5.1	2	9.1.4.2	4	9.2.3.4	9			9.8.3.2	7		
	20		20		17		13		19		19		17		12		20		12		20		14

Pilot:

A/C:

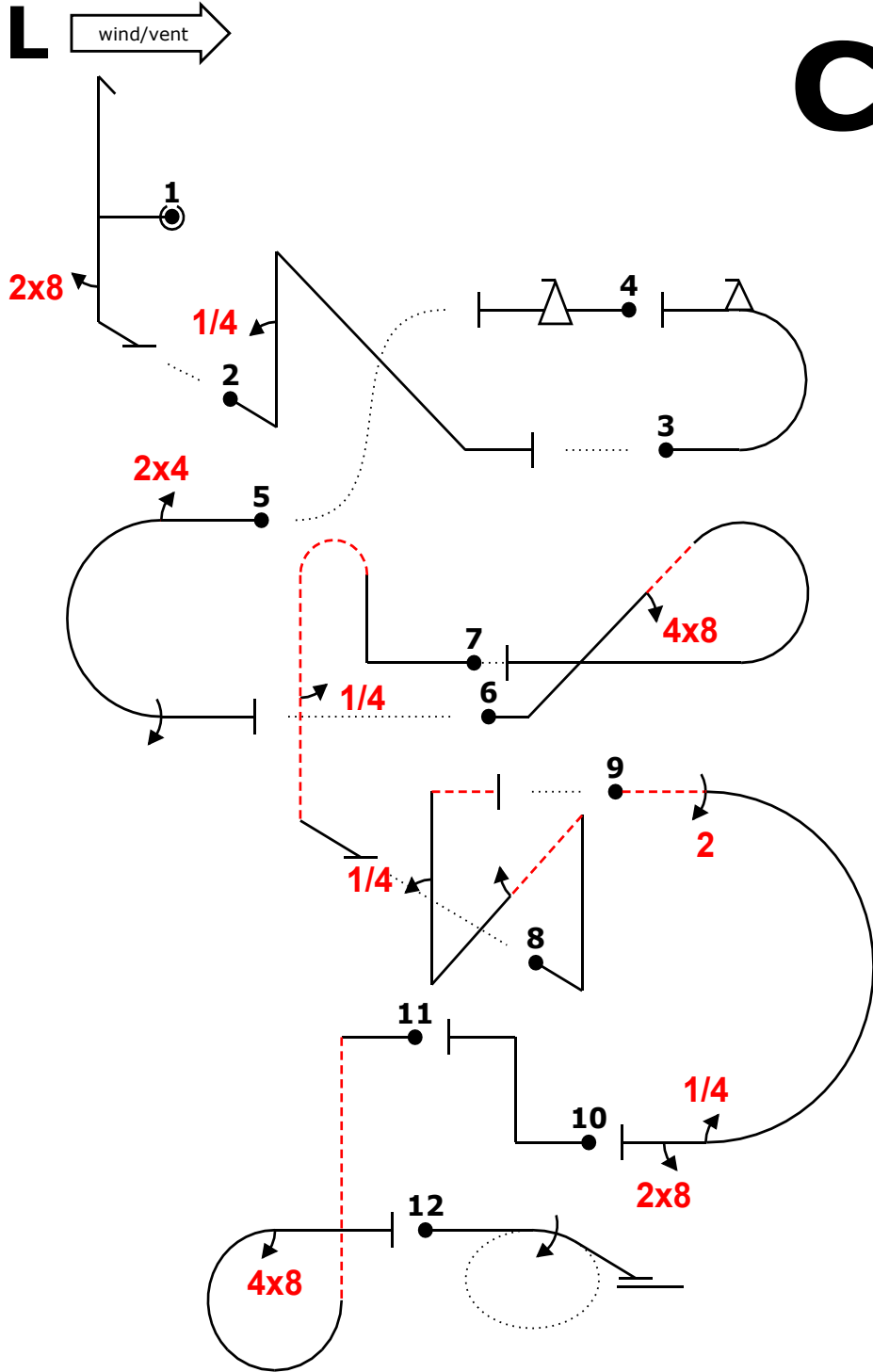

Fig	Grade	Pos	Remarks
1	.		
2	.		
3	.		
4	.		
5	.		
6	.		
7	.		
8	.		
9	.		
10	.		
11	.		
12	.		

Positioning **30** .

Too Low		Trg Violation	
Too High		Wing Rocks	
Interruptions		Disqual Fig	
Insertions		Other(note...)	

"@D" h8 (-2,1) "@E" ,4k (-4,0) "@A" m2f "@H" f (9,12) 4% "@C" 24a1 (-10,0) "@I" ``+48rc (-2,0) "@J" ``pb',4. (-7,4) "@L" n(''2..'),4'- (-3,0) 15% "@F" -''22a4,8+'' "@L" v'' "@B" .irp48~ "@G" 1j1

Fig 1 D	K	Fig 2 E	K	Fig 3 A	K	Fig 4 H	K	Fig 5 C	K	Fig 6 I	K	Fig 7 J	K	Fig 8 L	K	Fig 9 F	K	Fig 10 L	K	Fig 11 B	K	Fig 12 G	K
5.2.1.1	17	1.2.6.1	14	7.2.2.1	6	1.1.1.1	2	7.2.3.3	6	8.5.2.1	10	8.4.3.1	15	1.3.1.1	20	7.2.1.4	6	1.1.6.1	10	8.6.4.3	13	2.1.3.1	14
9.8.5.1	3	9.1.1.1	6	9.9.3.2	11	9.9.3.4	11	9.4.3.2	5	9.8.2.2	9	9.1.5.1	2	9.1.4.2	4	9.2.3.4	9			9.8.3.2	7		
	20		20		17		13		19		19		17		12		20		12		20		14

Pilot:

A/C:

D

wind/vent ← **R**

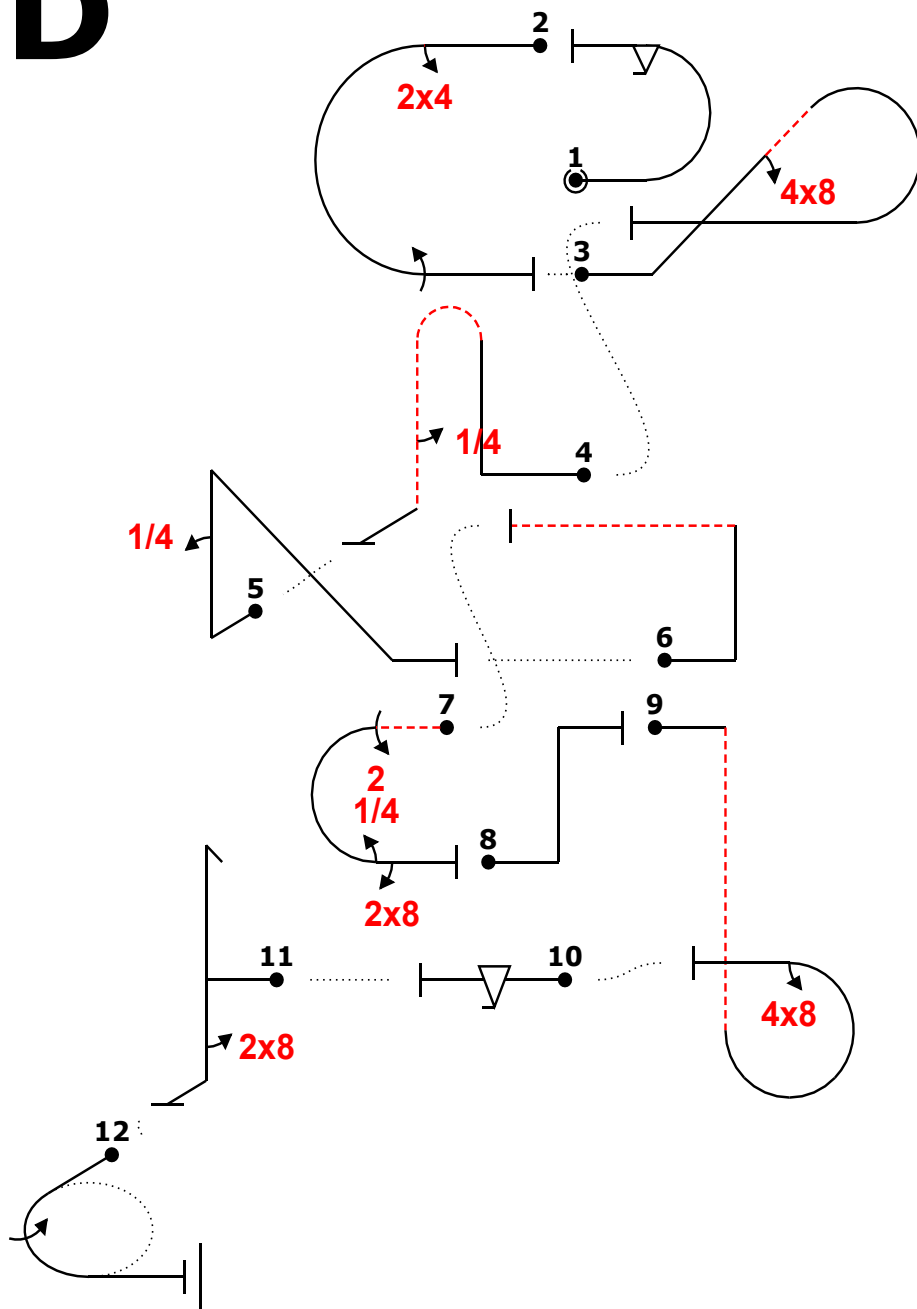

Fig	Grade	Pos	Remarks
1	.		
2	.		
3	.		
4	.		
5	.		
6	.		
7	.		
8	.		
9	.		
10	.		
11	.		
12	.		

Positioning **30** .

Too Low		Trg Violation	
Too High		Wing Rocks	
Interruptions		Disqual Fig	
Insertions		Other(note...)	

"@A" m2f "@C" 7% 24a1 (-1,0) "I" ,48rc (1,15) "J" pb4 (-3,2) "E" 4k (9,0) "L" v----- (0,12) "F" -22a4,28 " " @L" v "@B" ..irp48 (-4,1) "H" f (-5,0) "D" h28 (0,1) "G" 1j1

Fig 1 A	K	Fig 2 C	K	Fig 3 I	K	Fig 4 J	K	Fig 5 E	K	Fig 6 L	K	Fig 7 F	K	Fig 8 L	K	Fig 9 B	K	Fig 10 H	K	Fig 11 D	K	Fig 12 G	K
7.2.2.1	6	7.2.3.3	6	8.5.2.1	10	8.4.3.1	15	1.2.6.1	14	1.1.7.1	9	7.2.1.4	6	1.1.6.1	10	8.6.4.3	13	1.1.1.1	2	5.2.1.1	17	2.1.3.1	14
9.9.3.2	11	9.4.3.2	5	9.8.2.2	9	9.1.5.1	2	9.1.1.1	6			9.2.3.4	9			9.8.3.2	7	9.9.3.4	11	9.8.5.1	3		
		9.1.3.4	8									9.1.3.1	2										
	17		19		19		17		20		12		20		12		20		13		20		14

Pilot:

A/C:



Figure K
203
 Total K
233

Judges Name		Flight #
Signature	Number	

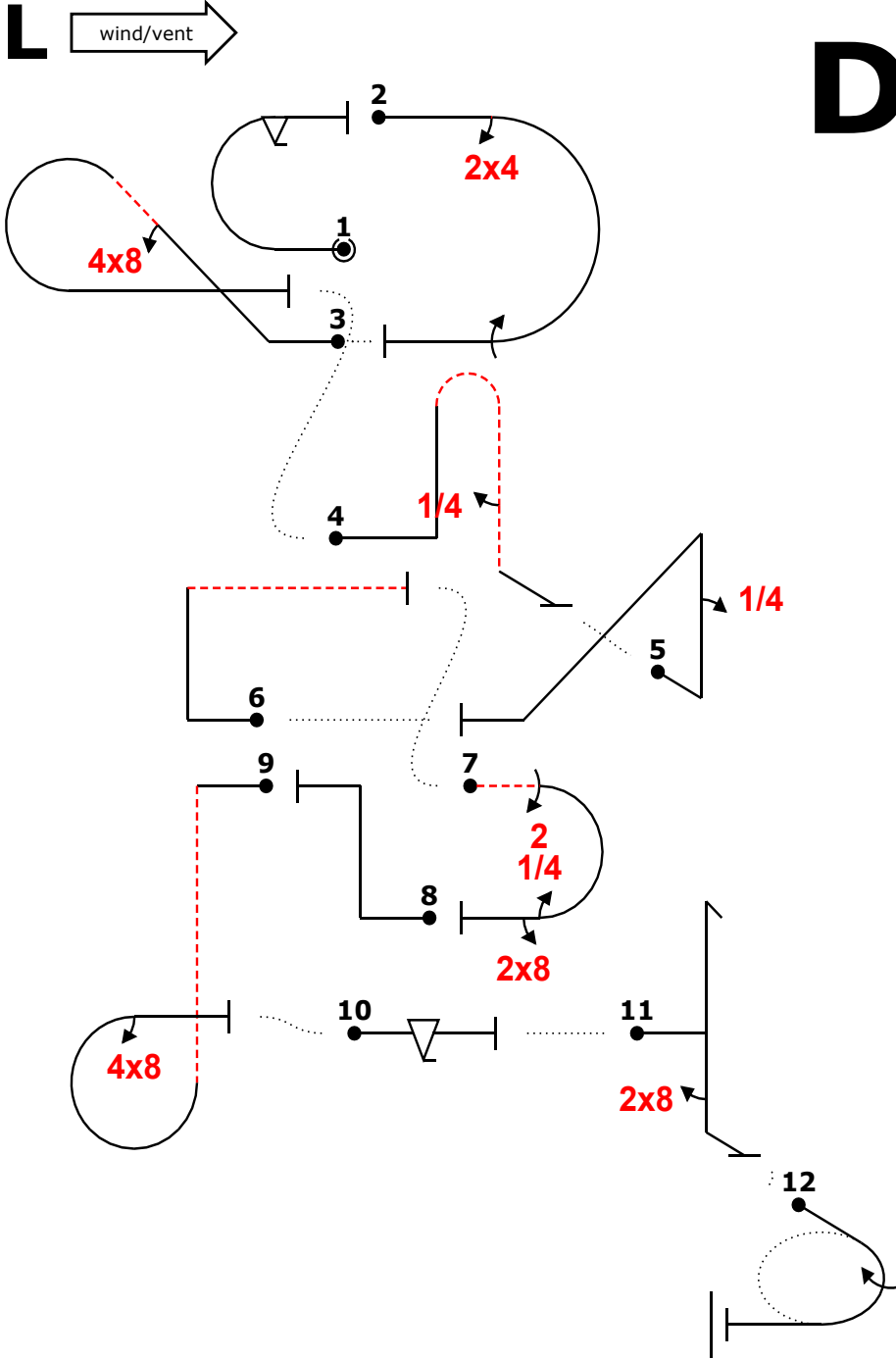

Fig	Grade	Pos	Remarks
1	.		
2	.		
3	.		
4	.		
5	.		
6	.		
7	.		
8	.		
9	.		
10	.		
11	.		
12	.		

Positioning **30** .

Too Low		Trg Violation	
Too High		Wing Rocks	
Interruptions		Disqual Fig	
Insertions		Other(note...)	

"@A" m2f "@C" 7% 24a1 (-1,0) "@I" ,48rc (1,15) "@J" pb4 (-3,2) "@E" 4k (9,0) "@L" v----- (0,12) "@F" -22a4,28 " "@L" v "@B" ..irp48 (-4,1) "@H" f (-5,0) "@D" h28 (0,1) "@G" 1j1

Fig 1 A	K	Fig 2 C	K	Fig 3 I	K	Fig 4 J	K	Fig 5 E	K	Fig 6 L	K	Fig 7 F	K	Fig 8 L	K	Fig 9 B	K	Fig 10 H	K	Fig 11 D	K	Fig 12 G	K
7.2.2.1	6	7.2.3.3	6	8.5.2.1	10	8.4.3.1	15	1.2.6.1	14	1.1.7.1	9	7.2.1.4	6	1.1.6.1	10	8.6.4.3	13	1.1.1.1	2	5.2.1.1	17	2.1.3.1	14
9.9.3.2	11	9.4.3.2	5	9.8.2.2	9	9.1.5.1	2	9.1.1.1	6			9.2.3.4	9			9.8.3.2	7	9.9.3.4	11	9.8.5.1	3		
		9.1.3.4	8									9.1.3.1	2										
	17		19		19		17		20		12		20		12		20		13		20		14

Pilot:

A/C:

E

wind/vent ← **R**

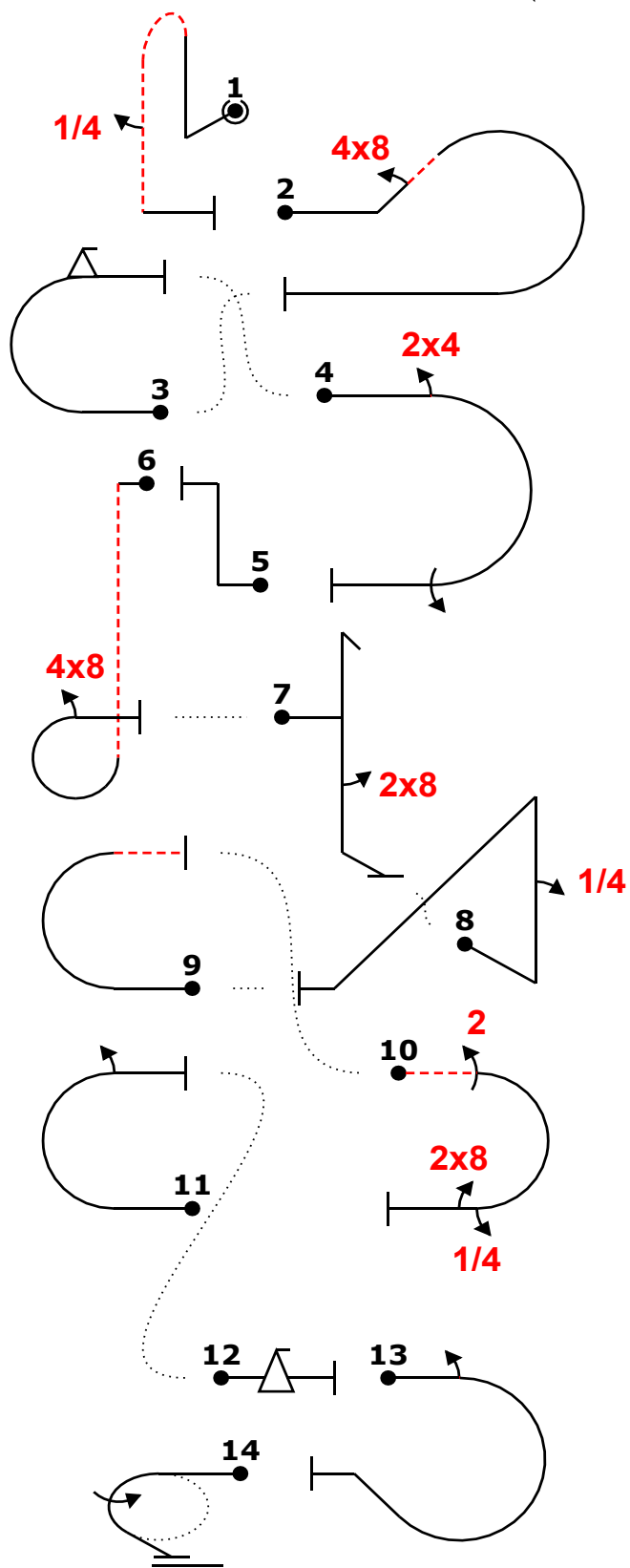

Fig	Grade	Pos	Remarks
1	.		
2	.		
3	.		
4	.		
5	.		
6	.		
7	.		
8	.		
9	.		
10	.		
11	.		
12	.		
13	.		
14	.		

Positioning **30** .

Too Low		Trg Violation	
Too High		Wing Rocks	
Interruptions		Disqual Fig	
Insertions		Other(note...)	

ej "@J" ~~~+pb~~,4+~~ "I" 2> 2% ~~~~~48~~rc+~~~~ (-3,7) "@A" m2f (5,7) "@C" 4% 24a1 "@L" 2> ~~~+v~~+~~ " @B" -4% ~~~+.....irp48 [4,0] "@D" /+~~~h8" (1,2) "@E" ~~~,4+k+~~ (-2,0) "@L" m- (8,13) "@F" -22a4,28 "@L" 9> m 2 (-2,18) "@H" -1% ~f+~~ "@L" > 2% ~~~~~2ic~~~~~+~~ "@G" -3% 2> 1j1

Fig 1 J	K	Fig 2 I	K	Fig 3 A	K	Fig 4 C	K	Fig 5 L	K	Fig 6 B	K	Fig 7 D	K	Fig 8 E	K	Fig 9 L	K	Fig 10 F	K	Fig 11 L	K	Fig 12 H	K	Fig 13 L	K	Fig 14 G	K
8.4.3.1	15	8.5.2.1	10	7.2.2.1	6	7.2.3.3	6	1.1.6.1	10	8.6.4.3	13	5.2.1.1	17	1.2.6.1	14	7.2.1.1	6	7.2.1.4	6	7.2.2.1	6	1.1.1.1	2	8.5.7.3	10	2.1.3.1	14
9.1.5.1	2	9.8.2.2	9	9.9.3.2	11	9.4.3.2	5			9.8.3.2	7	9.8.5.1	3	9.1.1.1	6			9.2.3.4	9	9.1.3.2	4	9.9.3.4	11	9.1.3.2	4		
						9.1.3.4	8											9.1.3.1	2								
																		9.8.3.1	3								
	17		19		17		19		6		20		20		20		6		20		6		13		6		14

Pilot:

A/C:



CIVA Intermediate 2024
 Programme2 EIAC

Figure K
203
 Total K
233

Judges Name		Flight #
Signature	Number	

**E**

Fig	Grade	Pos	Remarks
1	.		
2	.		
3	.		
4	.		
5	.		
6	.		
7	.		
8	.		
9	.		
10	.		
11	.		
12	.		
13	.		
14	.		

Positioning
30

Too Low		Trg Violation	
Too High		Wing Rocks	
Interruptions		Disqual Fig	
Insertions		Other(note...)	

ej "@j" \+\pb\,4'+\ "I" 2> 2%48\rc+ (-3,7) "@A" m2f (5,7) "@C" 4% 24a1 "@L" 2> \+\v\'+\ " @B" -4% \+\+...irp48 [4,0] "@D" /+\h8" (1,2) "@E" ~~,4'k+\ (-2,0) "@L" m- (8,13) "@F" -22a4,28 "@L" 9> m 2 (-2,18) "@H" -1% \f+\ "@L" > 2%2ic.....+\ "@G" -3% 2> 1j1

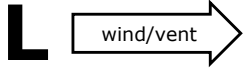
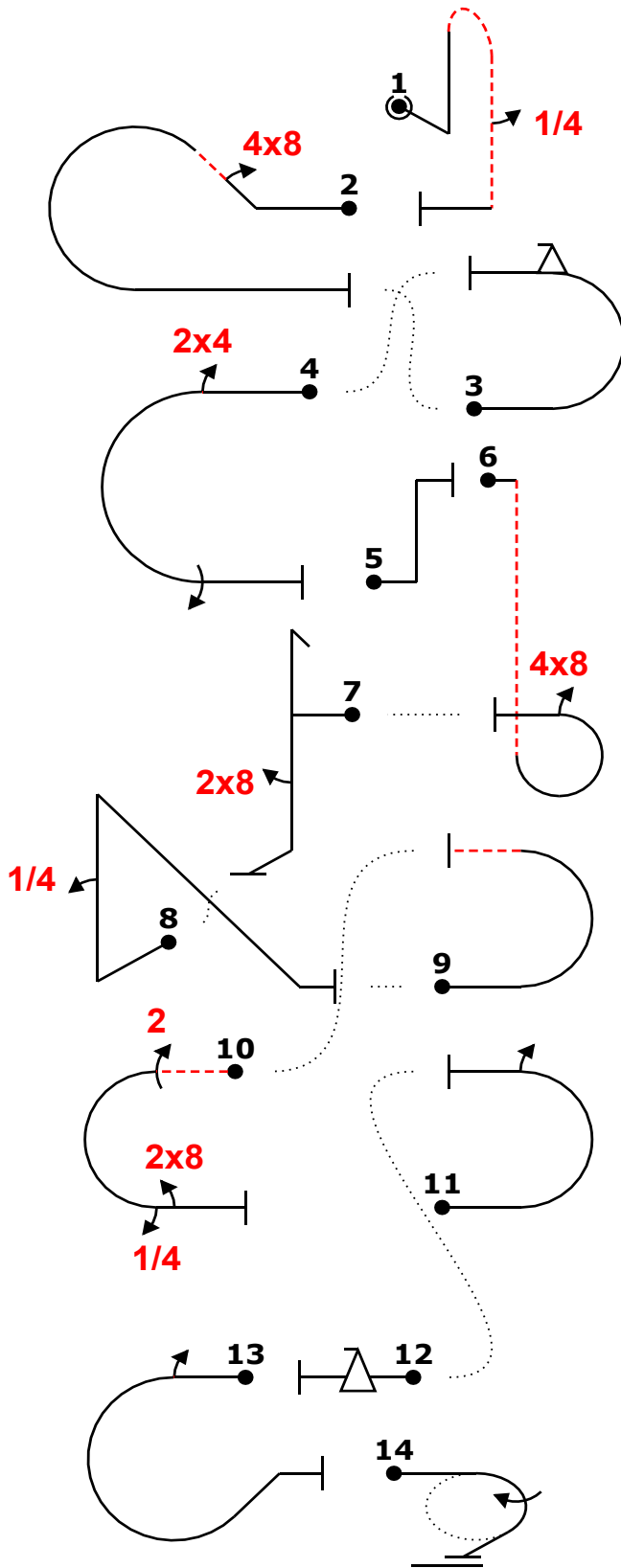
Fig 1 J	K	Fig 2 I	K	Fig 3 A	K	Fig 4 C	K	Fig 5 L	K	Fig 6 B	K	Fig 7 D	K	Fig 8 E	K	Fig 9 L	K	Fig 10 F	K	Fig 11 L	K	Fig 12 H	K	Fig 13 L	K	Fig 14 G	K
8.4.3.1	15	8.5.2.1	10	7.2.2.1	6	7.2.3.3	6	1.1.6.1	10	8.6.4.3	13	5.2.1.1	17	1.2.6.1	14	7.2.1.1	6	7.2.1.4	6	7.2.2.1	6	1.1.1.1	2	8.5.7.3	10	2.1.3.1	14
9.1.5.1	2	9.8.2.2	9	9.9.3.2	11	9.4.3.2	5			9.8.3.2	7	9.8.5.1	3	9.1.1.1	6			9.2.3.4	9	9.1.3.2	4	9.9.3.4	11	9.1.3.2	4		
						9.1.3.4	8											9.1.3.1	2								
																		9.8.3.1	3								
	17		19		17		19		6		20		20		20		6		20		6		13		6		14

Pilot:

A/C:

F

wind/vent ← **R**

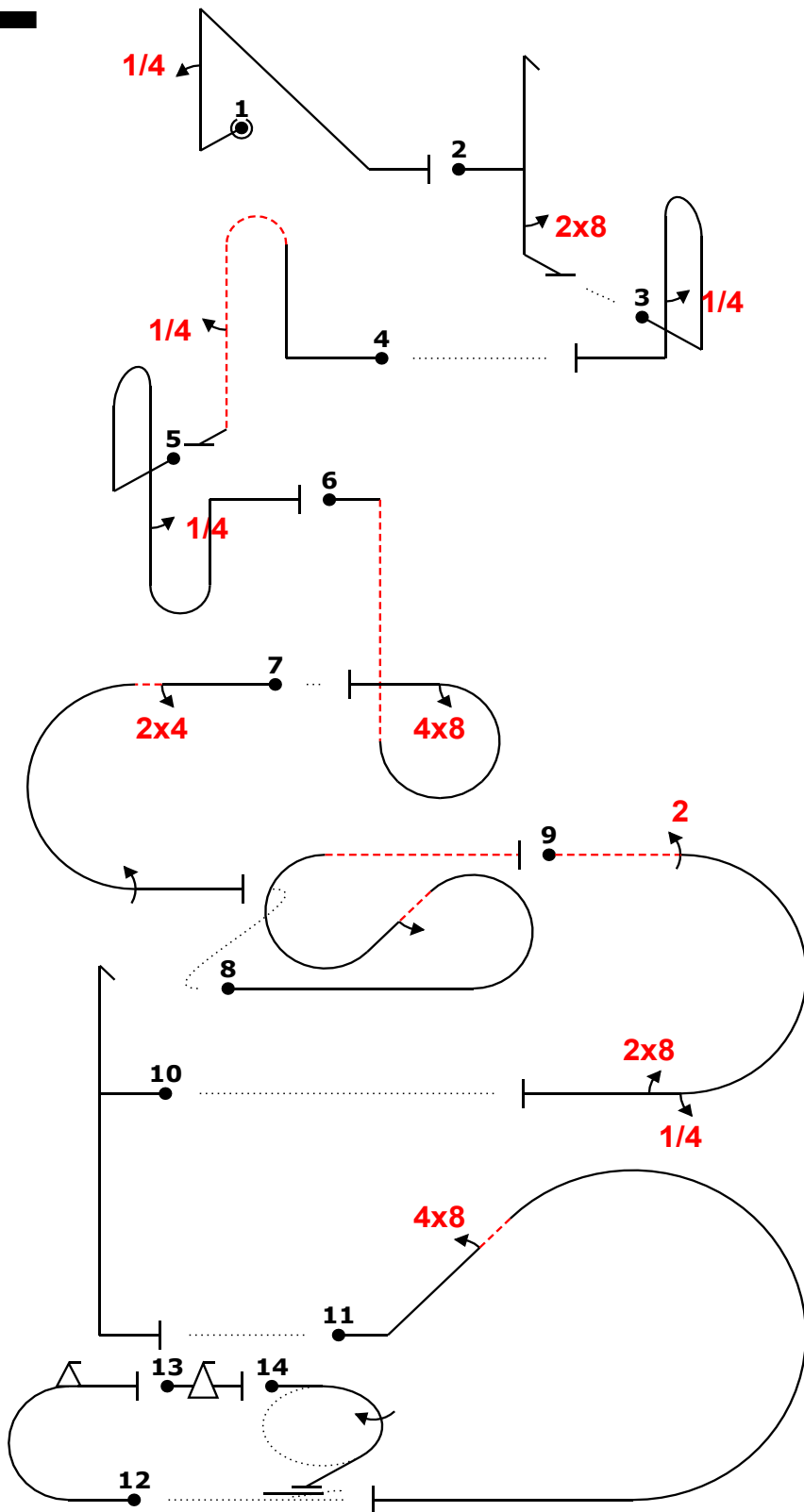

Fig	Grade	Pos	Remarks
1	.		
2	.		
3	.		
4	.		
5	.		
6	.		
7	.		
8	.		
9	.		
10	.		
11	.		
12	.		
13	.		
14	.		

Positioning **30** .

Too Low		Trg Violation	
Too High		Wing Rocks	
Interruptions		Disqual Fig	
Insertions		Other(note...)	

ej "@E" 4k "@D" /h28 (2,1) "@L" b4 (-9,0) "@J" /pb,4,+"" "@L" bb(4) "@B" "+." irp48 (-1,0) "@C" 8% 24'a1 (-5,7) "@L" ac(2)-"" "@F" 11% -22a4,8 (-20,0) "@L" 'h....' (8,0) "@I" 19% ""+"" 48""nc+"" (-12,0) "@A" " m2f "@H" ""f+"" "@G" ""+1j1 (3,0) "HUN V2"

Fig 1 E	K	Fig 2 D	K	Fig 3 L	K	Fig 4 J	K	Fig 5 L	K	Fig 6 B	K	Fig 7 C	K	Fig 8 L	K	Fig 9 F	K	Fig 10 L	K	Fig 11 I	K	Fig 12 A	K	Fig 13 H	K	Fig 14 G	K
1.2.6.1	14	5.2.1.1	17	8.4.1.1	13	8.4.3.1	15	8.8.2.1	19	8.6.4.3	13	7.2.3.3	6	7.5.2.1	15	7.2.1.4	6	5.2.1.1	17	8.5.2.1	10	7.2.2.1	6	1.1.1.1	2	2.1.3.1	14
9.1.1.1	6	9.8.5.1	3	9.1.5.1	2	9.1.5.1	2	9.1.5.1	2	9.8.3.2	7	9.4.3.2	5	9.1.4.2	4	9.2.3.4	9			9.8.2.2	9	9.9.3.2	11	9.9.3.4	11		
	20		20		6		17		6		20		19		6		20		6		19		17		13		14

Pilot:

A/C:



Figure K
203
 Total K
233

Judges Name		Flight #
Signature	Number	

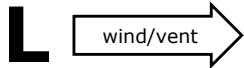

F

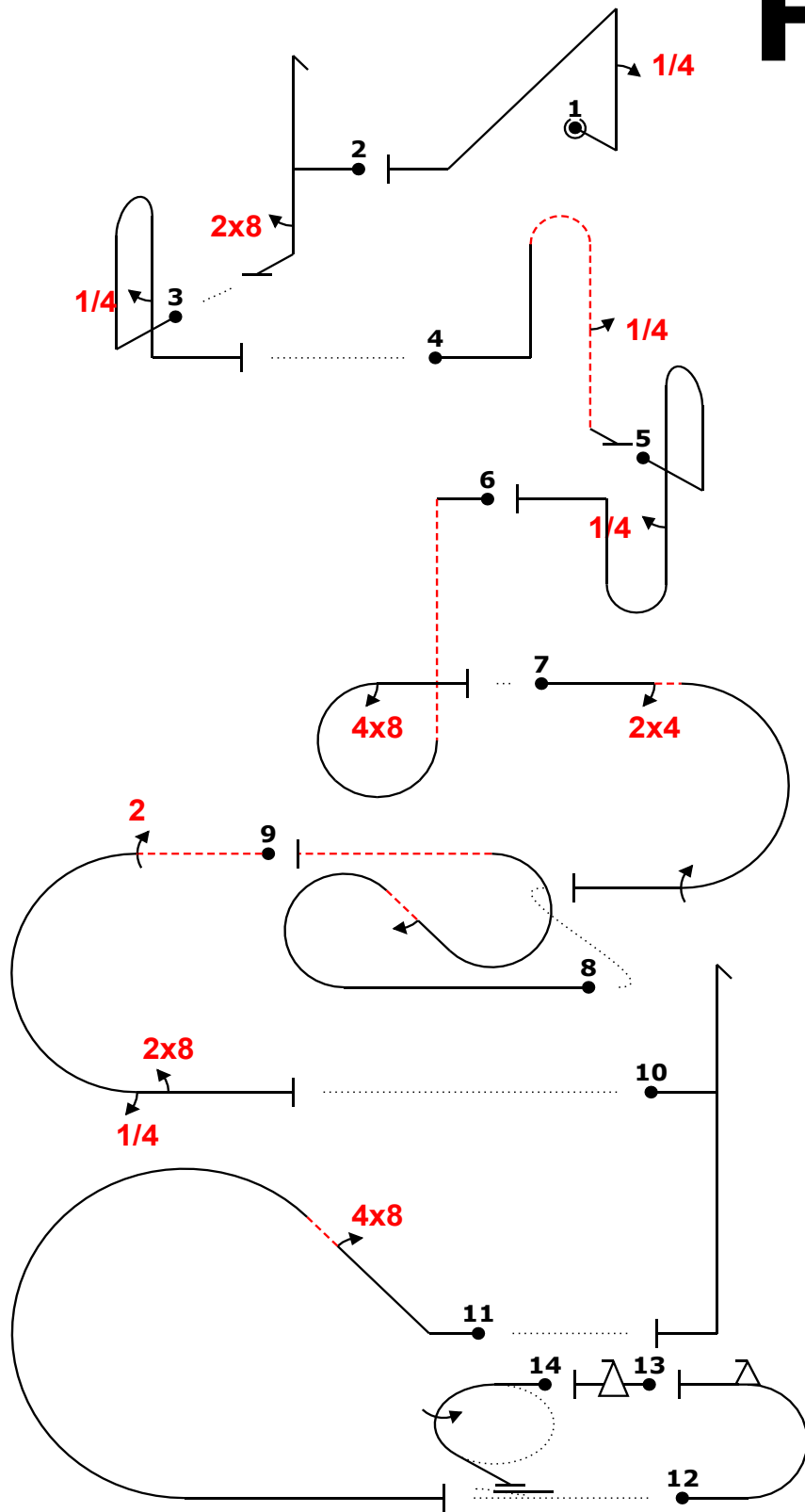

Fig	Grade	Pos	Remarks
1	.		
2	.		
3	.		
4	.		
5	.		
6	.		
7	.		
8	.		
9	.		
10	.		
11	.		
12	.		
13	.		
14	.		

Positioning **30**

Too Low		Trg Violation	
Too High		Wing Rocks	
Interruptions		Disqual Fig	
Insertions		Other(note...)	

ej "@E" 4k "@D" /h28 (2,1) "@L" b4 (-9,0) "@J" /pb,4,+"" "@L" bb(4) "@B" "+." irp48 (-1,0) "@C" 8% 24'a1 (-5,7) "@L" ac(2)-"" "@F" 11% -22a4,8 (-20,0) "@L" 'h...' (8,0) "@I" 19% ""+"" 48""nc+"" (-12,0) "@A" " m2f "@H" ""f+"" "@G" ""+1j1 (3,0) "HUN V2"

Fig 1 E	K	Fig 2 D	K	Fig 3 L	K	Fig 4 J	K	Fig 5 L	K	Fig 6 B	K	Fig 7 C	K	Fig 8 L	K	Fig 9 F	K	Fig 10 L	K	Fig 11 I	K	Fig 12 A	K	Fig 13 H	K	Fig 14 G	K
1.2.6.1	14	5.2.1.1	17	8.4.1.1	13	8.4.3.1	15	8.8.2.1	19	8.6.4.3	13	7.2.3.3	6	7.5.2.1	15	7.2.1.4	6	5.2.1.1	17	8.5.2.1	10	7.2.2.1	6	1.1.1.1	2	2.1.3.1	14
9.1.1.1	6	9.8.5.1	3	9.1.5.1	2	9.1.5.1	2	9.1.5.1	2	9.8.3.2	7	9.4.3.2	5	9.1.4.2	4	9.2.3.4	9			9.8.2.2	9	9.9.3.2	11	9.9.3.4	11		
	20		20		6		17		6		20		19		6		20		6		19		17		13		14

Pilot:

A/C:

G

wind/vent **R**

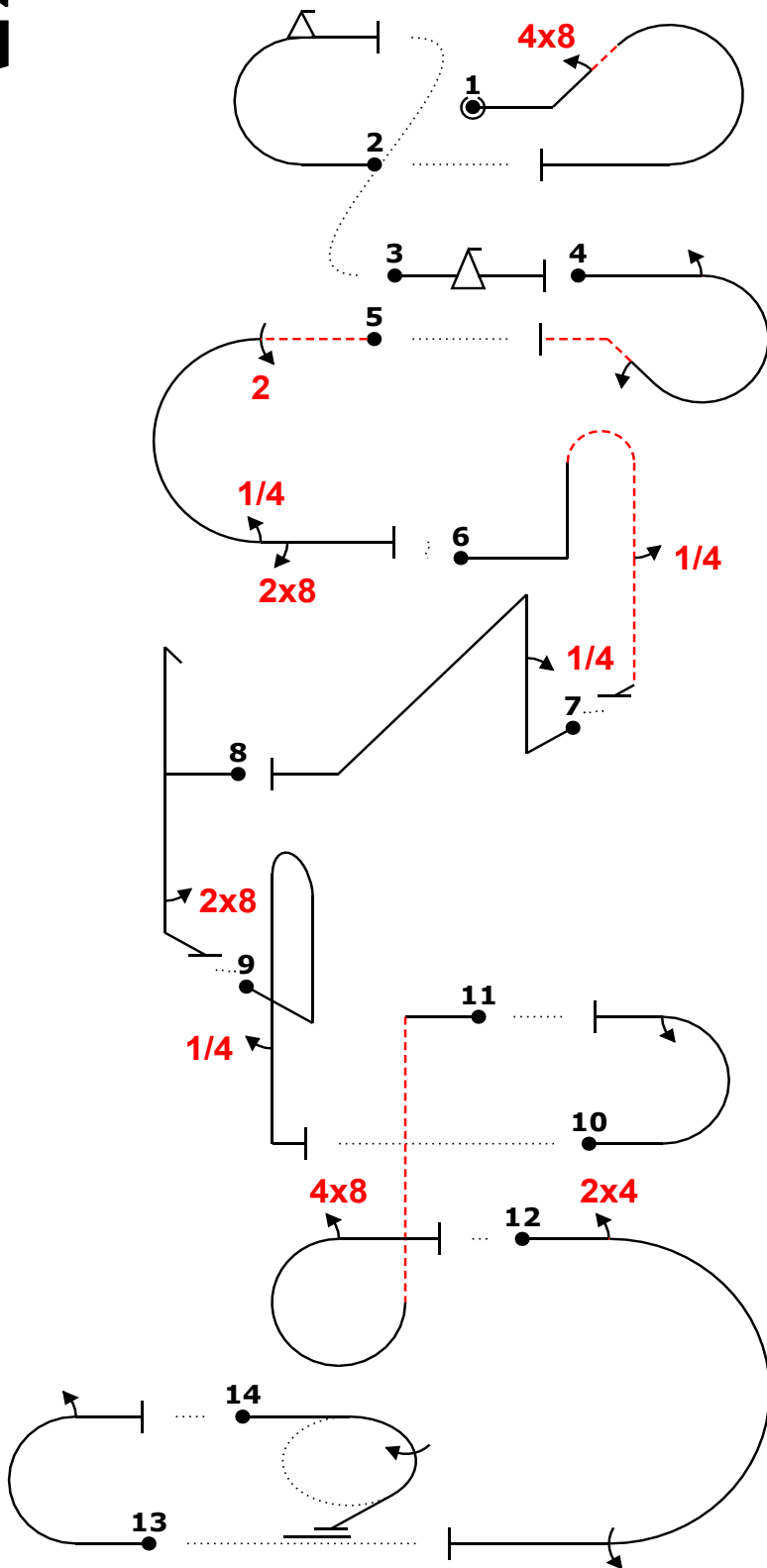

Fig	Grade	Pos	Remarks
1	.		
2	.		
3	.		
4	.		
5	.		
6	.		
7	.		
8	.		
9	.		
10	.		
11	.		
12	.		
13	.		
14	.		

Positioning **30**

Too Low		Trg Violation	
Too High		Wing Rocks	
Interruptions		Disqual Fig	
Insertions		Other(note...)	

"@I" 1% ~~~~~48`rc+ ~~~~~ (-6,0) "@A" m2f (-3,15) "@H" f "@L" ~~~~~2ic'2 ~~~~~ (-6,0) "@F" 6% -22a4,28 (0,1) "@J" ~~~~~pb4.'+ ~~~~~ (1,0) "@E" ,4k "@D" /h.'8 (-1,0) "@L" b.'',4'+ ~~~~~ (13,0) "@L" m2 (-3,0) "@B" ..irp4 8 (1,0) "@C" 14% ~~~~~24a1 (-14,0) "@L" m2 (2,0) "@G" /1j1 (2,2) "HUN V2"

Fig 1 I	K	Fig 2 A	K	Fig 3 H	K	Fig 4 L	K	Fig 5 F	K	Fig 6 J	K	Fig 7 E	K	Fig 8 D	K	Fig 9 L	K	Fig 10 L	K	Fig 11 B	K	Fig 12 C	K	Fig 13 L	K	Fig 14 G	K
8.5.2.1	10	7.2.2.1	6	1.1.1.1	2	8.5.8.3	11	7.2.1.4	6	8.4.3.1	15	1.2.6.1	14	5.2.1.1	17	8.4.1.1	13	7.2.2.1	6	8.6.4.3	13	7.2.3.3	6	7.2.2.1	6	2.1.3.1	14
9.8.2.2	9	9.9.3.2	11	9.9.3.4	11	9.1.3.2	4	9.2.3.4	9	9.1.5.1	2	9.1.1.1	6	9.8.5.1	3	9.1.5.1	2	9.1.3.2	4	9.8.3.2	7	9.4.3.2	5	9.1.3.2	4		
	19		17		13	9.1.2.2	6	9.1.3.1	2		17		20		6		6		6	20		19		6		14	

Pilot:

A/C:

L wind/vent →

G

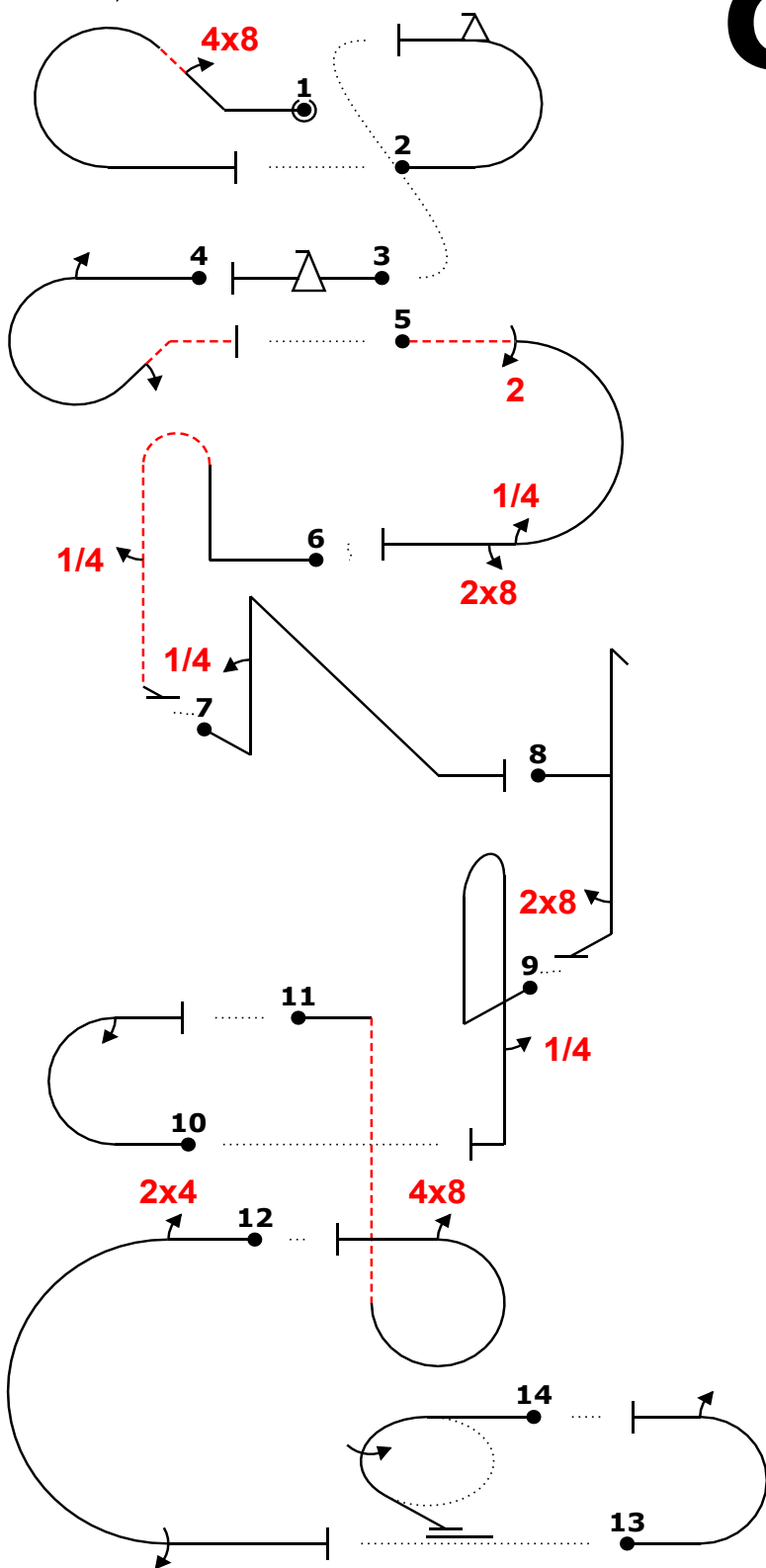

Fig	Grade	Pos	Remarks
1	.		
2	.		
3	.		
4	.		
5	.		
6	.		
7	.		
8	.		
9	.		
10	.		
11	.		
12	.		
13	.		
14	.		

Positioning **30** .

Too Low		Trg Violation	
Too High		Wing Rocks	
Interruptions		Disqual Fig	
Insertions		Other(note...)	

"@I" 1% ~~~~~48`rc+~~~~~ (-6,0) "@A" m2f (-3,15) "@H" f "@L" ~~~~~2ic'2~~~~~ (-6,0) "@F" 6% -22a4,28 (0,1) "@J" ~~~pb4.+~~~~~ (1,0) "@E",4k "@D" /h.'8 (-1,0) "@L" b.'.'4'+'~~~~~ (13,0) "@L" m2 (-3,0) "@B" ..irp4 8 (1,0) "@C" 14% ~~~24a1 (-14,0) "@L" m2 (2,0) "@G" /1j1 (2,2) "HUN V2"

Fig 1 I	K	Fig 2 A	K	Fig 3 H	K	Fig 4 L	K	Fig 5 F	K	Fig 6 J	K	Fig 7 E	K	Fig 8 D	K	Fig 9 L	K	Fig 10 L	K	Fig 11 B	K	Fig 12 C	K	Fig 13 L	K	Fig 14 G	K
8.5.2.1	10	7.2.2.1	6	1.1.1.1	2	8.5.8.3	11	7.2.1.4	6	8.4.3.1	15	1.2.6.1	14	5.2.1.1	17	8.4.1.1	13	7.2.2.1	6	8.6.4.3	13	7.2.3.3	6	7.2.2.1	6	2.1.3.1	14
9.8.2.2	9	9.9.3.2	11	9.9.3.4	11	9.1.3.2	4	9.2.3.4	9	9.1.5.1	2	9.1.1.1	6	9.8.5.1	3	9.1.5.1	2	9.1.3.2	4	9.8.3.2	7	9.4.3.2	5	9.1.3.2	4		
	19		17		13		6		20		17		20		6		6		20		19		6		14		

Pilot:

A/C:

H

wind/vent ← **R**

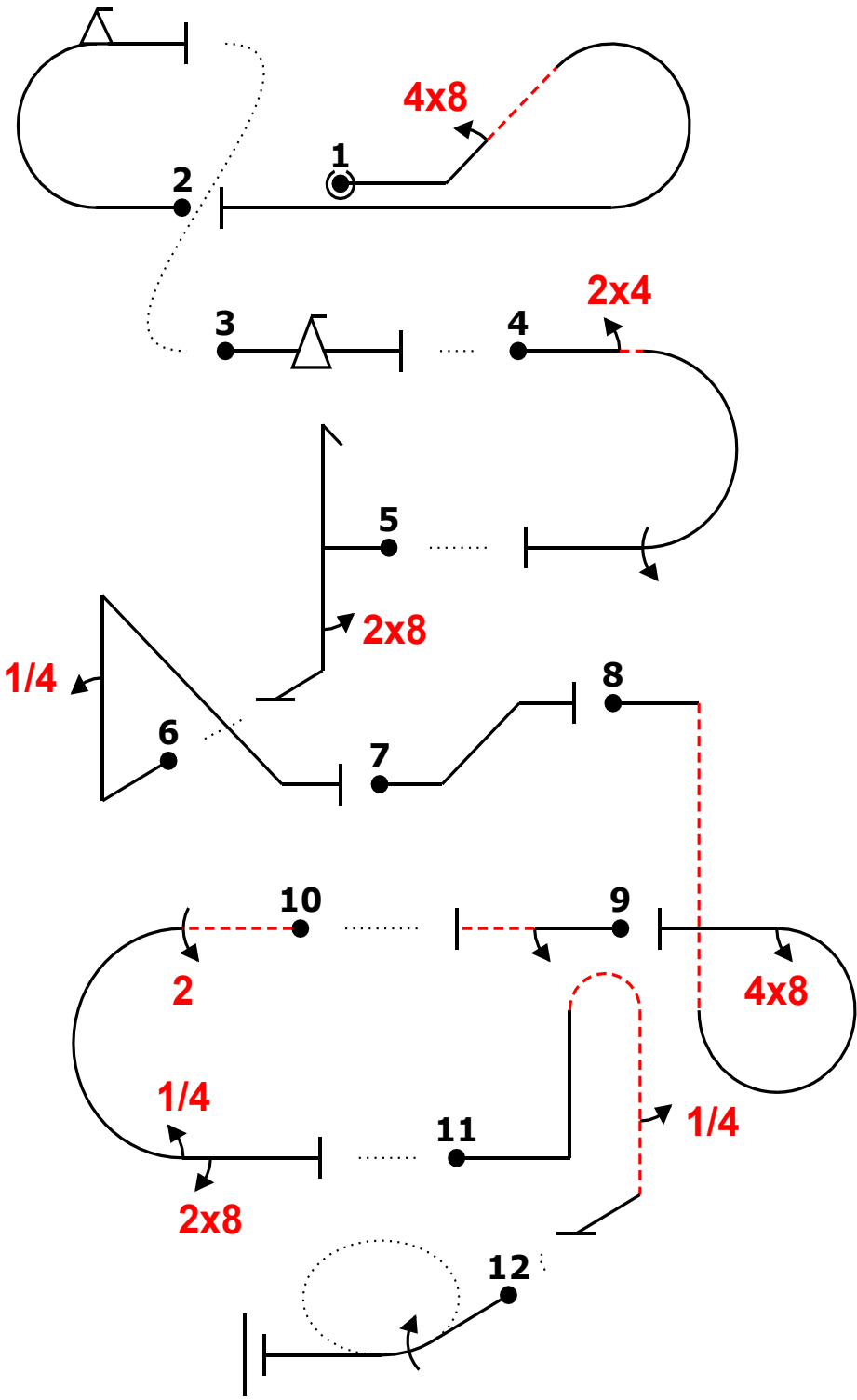

Fig	Grade	Pos	Remarks
1	.		
2	.		
3	.		
4	.		
5	.		
6	.		
7	.		
8	.		
9	.		
10	.		
11	.		
12	.		

Positioning 30 .

Too Low		Trg Violation	
Too High		Wing Rocks	
Interruptions		Disqual Fig	
Insertions		Other(note...)	

"@I" ~~~~~48'nc++ "@A" m2f (-2,15) "@H" f (2,0) "@C" 2% 24'a1~ (-3,0) "@D" `+`h8 (-2,1) "@E" ~4k`~+` "@L" -3% d "@B" .irp48 "@L" 2- (-4,0) "@F" 4% -22a4,8 (3,0) "@J" -1% pb4 (0,1) "@G" 1j1

Fig 1 I	K	Fig 2 A	K	Fig 3 H	K	Fig 4 C	K	Fig 5 D	K	Fig 6 E	K	Fig 7 L	K	Fig 8 B	K	Fig 9 L	K	Fig 10 F	K	Fig 11 J	K	Fig 12 G	K
8.5.2.1	10	7.2.2.1	6	1.1.1.1	2	7.2.3.3	6	5.2.1.1	17	1.2.6.1	14	1.1.2.1	7	8.6.4.3	13	1.1.1.3	2	7.2.1.4	6	8.4.3.1	15	2.1.3.1	14
9.8.2.2	9	9.9.3.2	11	9.9.3.4	11	9.4.3.2	5	9.8.5.1	3	9.1.1.1	6			9.8.3.2	7	9.1.3.2	4	9.2.3.4	9	9.1.5.1	2		
						9.1.3.4	8											9.1.3.1	2				
																		9.8.3.1	3				
	19		17		13		19		20		20		12		20		12		20		17		14

Pilot:

A/C:



Figure K
203
 Total K
233

Judges Name		Flight #
Signature	Number	

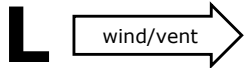

H

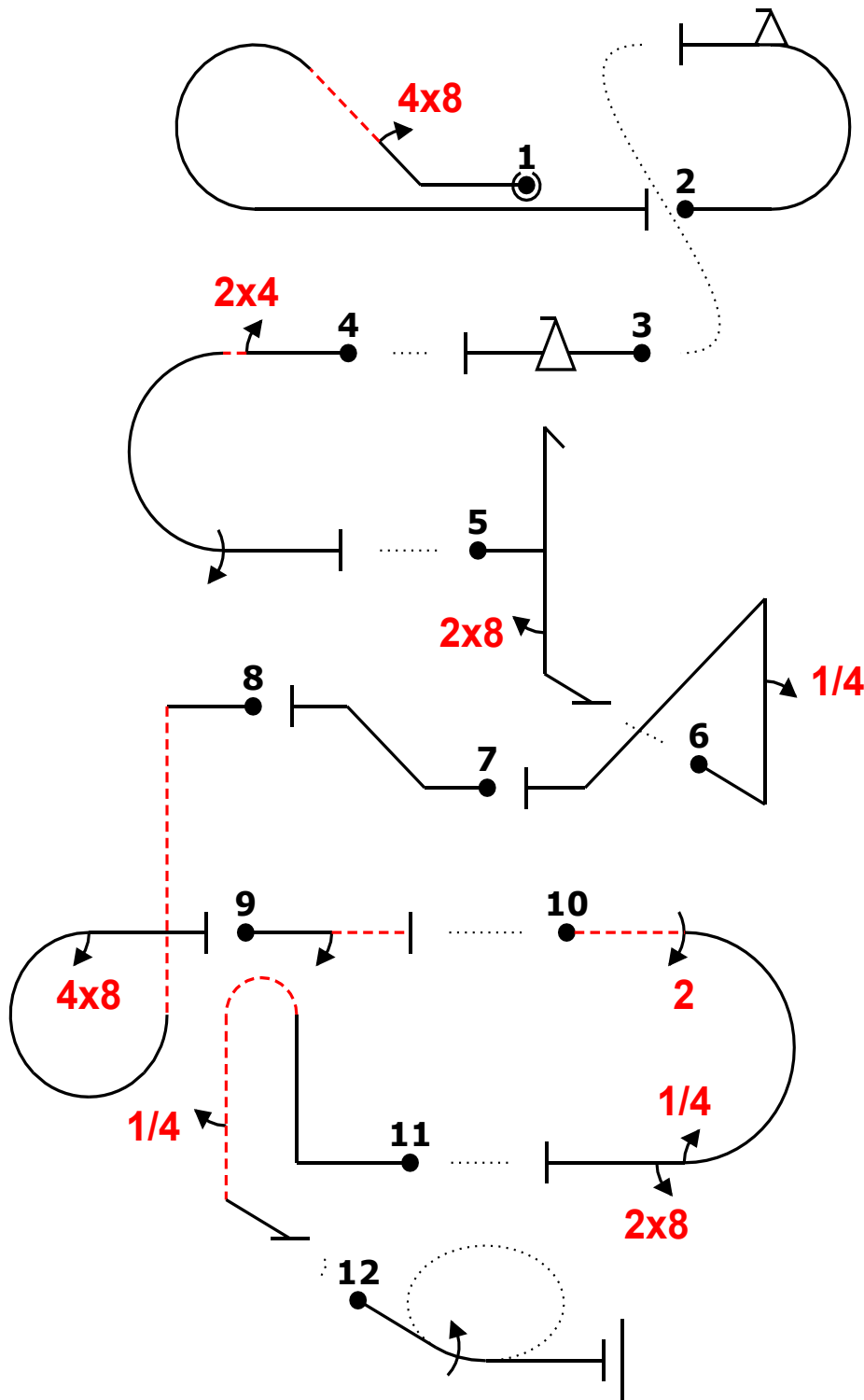

Fig	Grade	Pos	Remarks
1	.		
2	.		
3	.		
4	.		
5	.		
6	.		
7	.		
8	.		
9	.		
10	.		
11	.		
12	.		

Positioning **30** .

Too Low		Trg Violation	
Too High		Wing Rocks	
Interruptions		Disqual Fig	
Insertions		Other(note...)	

"@I" ~~~~~48'nc+ "@A" m2f (-2,15) "@H" f (2,0) "@C" 2% 24'a1~ (-3,0) "@D" ~~~h8 (-2,1) "@E" ~4k~~~+ "@L" -3% d "@B" .irp48 "@L" 2- (-4,0) "@F" 4% -22a4,8 (3,0) "@J" -1% pb4 (0,1) "@G" 1j1

Fig 1 I	K	Fig 2 A	K	Fig 3 H	K	Fig 4 C	K	Fig 5 D	K	Fig 6 E	K	Fig 7 L	K	Fig 8 B	K	Fig 9 L	K	Fig 10 F	K	Fig 11 J	K	Fig 12 G	K
8.5.2.1	10	7.2.2.1	6	1.1.1.1	2	7.2.3.3	6	5.2.1.1	17	1.2.6.1	14	1.1.2.1	7	8.6.4.3	13	1.1.1.3	2	7.2.1.4	6	8.4.3.1	15	2.1.3.1	14
9.8.2.2	9	9.9.3.2	11	9.9.3.4	11	9.4.3.2	5	9.8.5.1	3	9.1.1.1	6			9.8.3.2	7	9.1.3.2	4	9.2.3.4	9	9.1.5.1	2		
	19		17		13	9.1.3.4	8		20		20		12		20		12	9.1.3.1	2		17		14
																		9.8.3.1	3				

Pilot:

A/C:

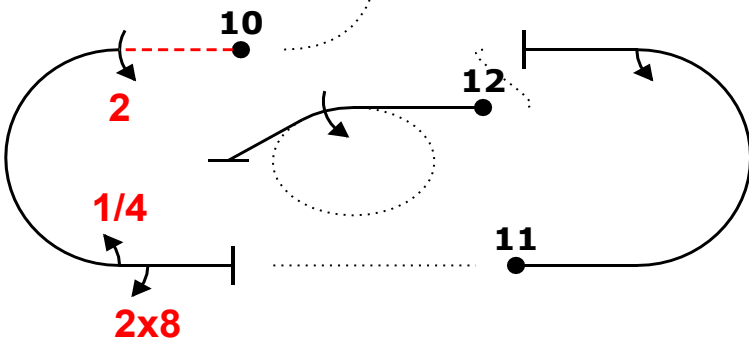
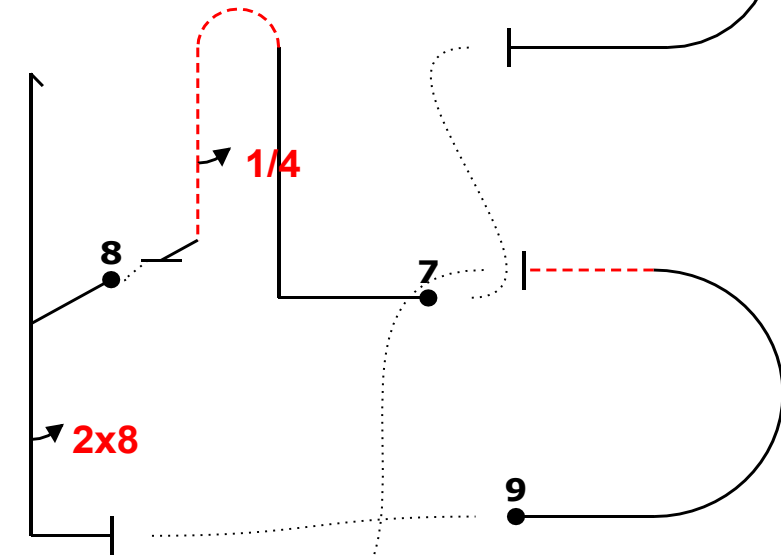
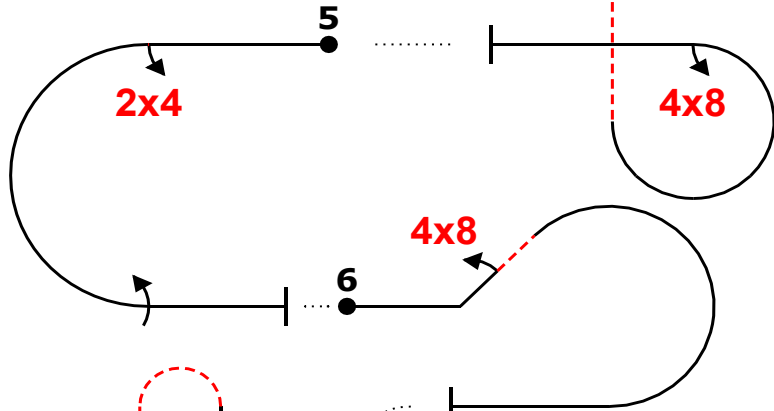
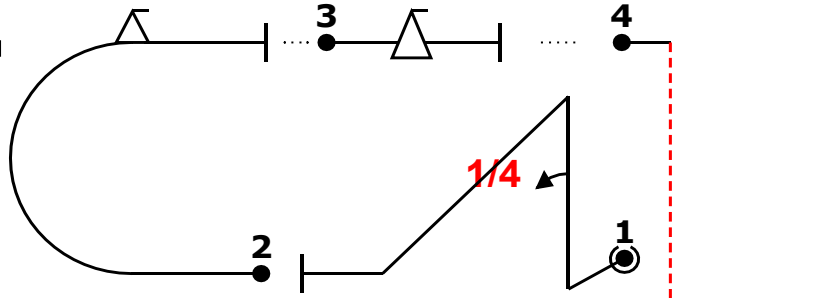
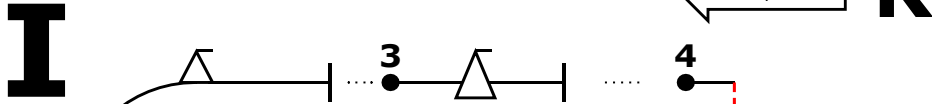

Fig	Grade	Pos	Remarks
1	.		
2	.		
3	.		
4	.		
5	.		
6	.		
7	.		
8	.		
9	.		
10	.		
11	.		
12	.		

Positioning **30**

Too Low		Trg Violation	
Too High		Wing Rocks	
Interruptions		Disqual Fig	
Insertions		Other(note...)	

ej "@E" 4k >> "@A" 5% m2f (-1,0) "@H" 9% f+ (2,0) "@B" +... irp48+~ (-4,0) "@C" 7% '24a1 (-1,0) "@I" 3 % 48' rc+ (0,13) "@J" ~...'pb4+... (1,-1) "@D" ~...'h'18. (16,-1) "@L" 6% m- (-10,18) "@F" 4% -2 2a4,8+ [10,0] "@L" 4% m2 (2,3) "@G" 1j1 eu

Fig 1 E	K	Fig 2 A	K	Fig 3 H	K	Fig 4 B	K	Fig 5 C	K	Fig 6 I	K	Fig 7 J	K	Fig 8 D	K	Fig 9 L	K	Fig 10 F	K	Fig 11 L	K	Fig 12 G	K
1.2.6.1	14	7.2.2.1	6	1.1.1.1	2	8.6.4.3	13	7.2.3.3	6	8.5.2.1	10	8.4.3.1	15	5.2.1.1	17	7.2.1.1	6	7.2.1.4	6	7.2.2.1	6	2.1.3.1	14
9.1.1.1	6	9.9.3.2	11	9.9.3.4	11	9.8.3.2	7	9.4.3.2	5	9.8.2.2	9	9.1.5.1	2	9.8.5.1	3			9.2.3.4	9	9.1.3.2	4		
								9.1.3.4	8									9.1.3.1	2				
																		9.8.3.1	3				
	20		17		13		20		19		19		17		20		12		20		12		14

Pilot:

A/C:



Figure K
203
 Total K
233

Judges Name		Flight #
Signature	Number	

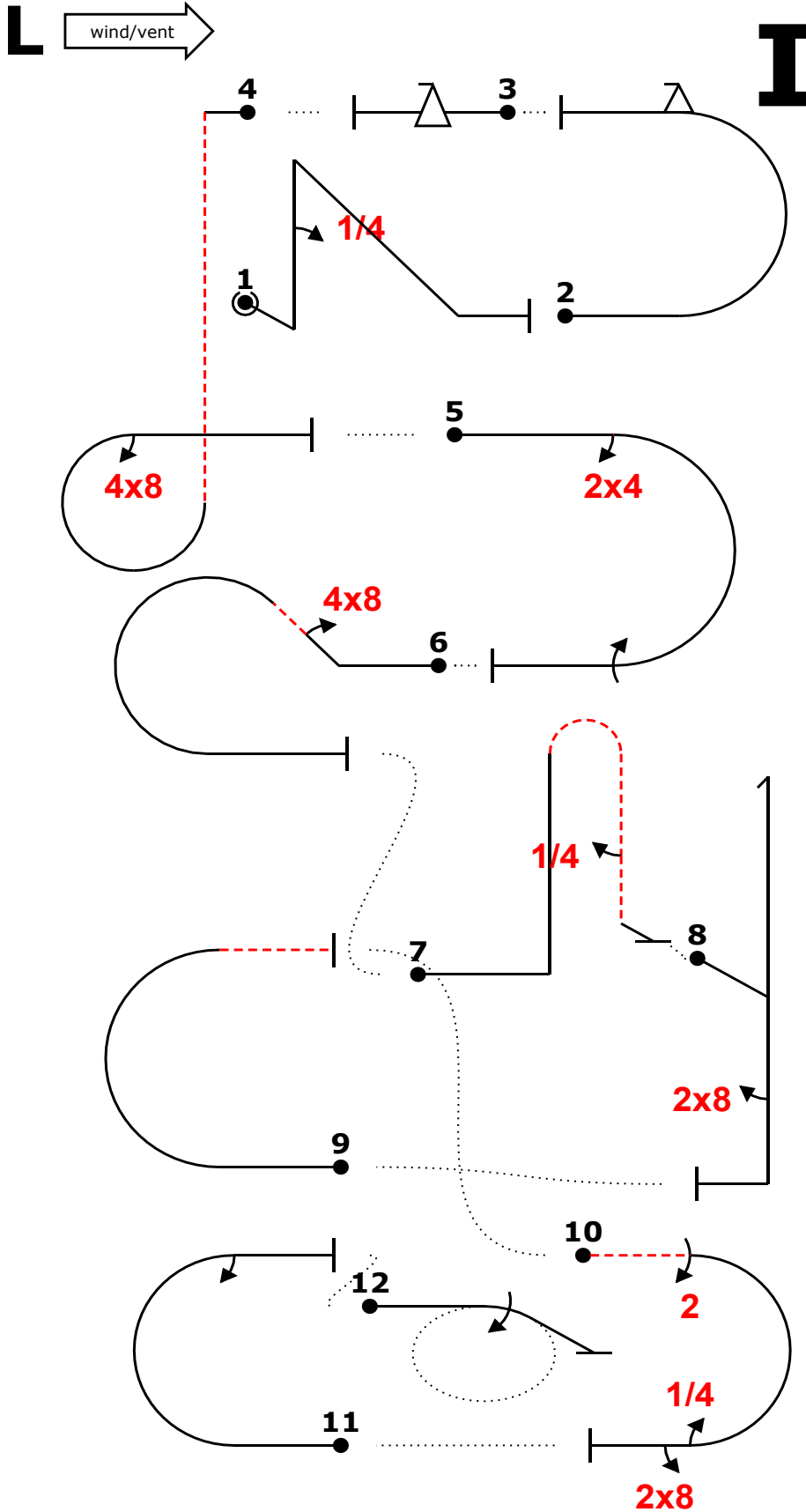

Fig	Grade	Pos	Remarks
1	.		
2	.		
3	.		
4	.		
5	.		
6	.		
7	.		
8	.		
9	.		
10	.		
11	.		
12	.		

Positioning **30** .

Too Low		Trg Violation	
Too High		Wing Rocks	
Interruptions		Disqual Fig	
Insertions		Other(note...)	

ej "@E" 4k >> "@A" 5% m2f (-1,0) "@H" 9% f (2,0) "@B" +... irp48+~ (-4,0) "@C" 7% '24a1 (-1,0) "@I" 3 % 48 rnc+ (0,13) "@J" ~' pb4+ (1,-1) "@D" ~' h''8. (16,-1) "@L" 6% m- (-10,18) "@F" 4% -2 2a4,8+ [10,0] "@L" 4% m2 (2,3) "@G" 1j1 eu

Fig 1 E	K	Fig 2 A	K	Fig 3 H	K	Fig 4 B	K	Fig 5 C	K	Fig 6 I	K	Fig 7 J	K	Fig 8 D	K	Fig 9 L	K	Fig 10 F	K	Fig 11 L	K	Fig 12 G	K
1.2.6.1	14	7.2.2.1	6	1.1.1.1	2	8.6.4.3	13	7.2.3.3	6	8.5.2.1	10	8.4.3.1	15	5.2.1.1	17	7.2.1.1	6	7.2.1.4	6	7.2.2.1	6	2.1.3.1	14
9.1.1.1	6	9.9.3.2	11	9.9.3.4	11	9.8.3.2	7	9.4.3.2	5	9.8.2.2	9	9.1.5.1	2	9.8.5.1	3			9.2.3.4	9	9.1.3.2	4		
								9.1.3.4	8									9.1.3.1	2				
																		9.8.3.1	3				
	20		17		13		20		19		19		17		20		12		20		12		14

Pilot:

A/C:

J **R**

wind/vent ←

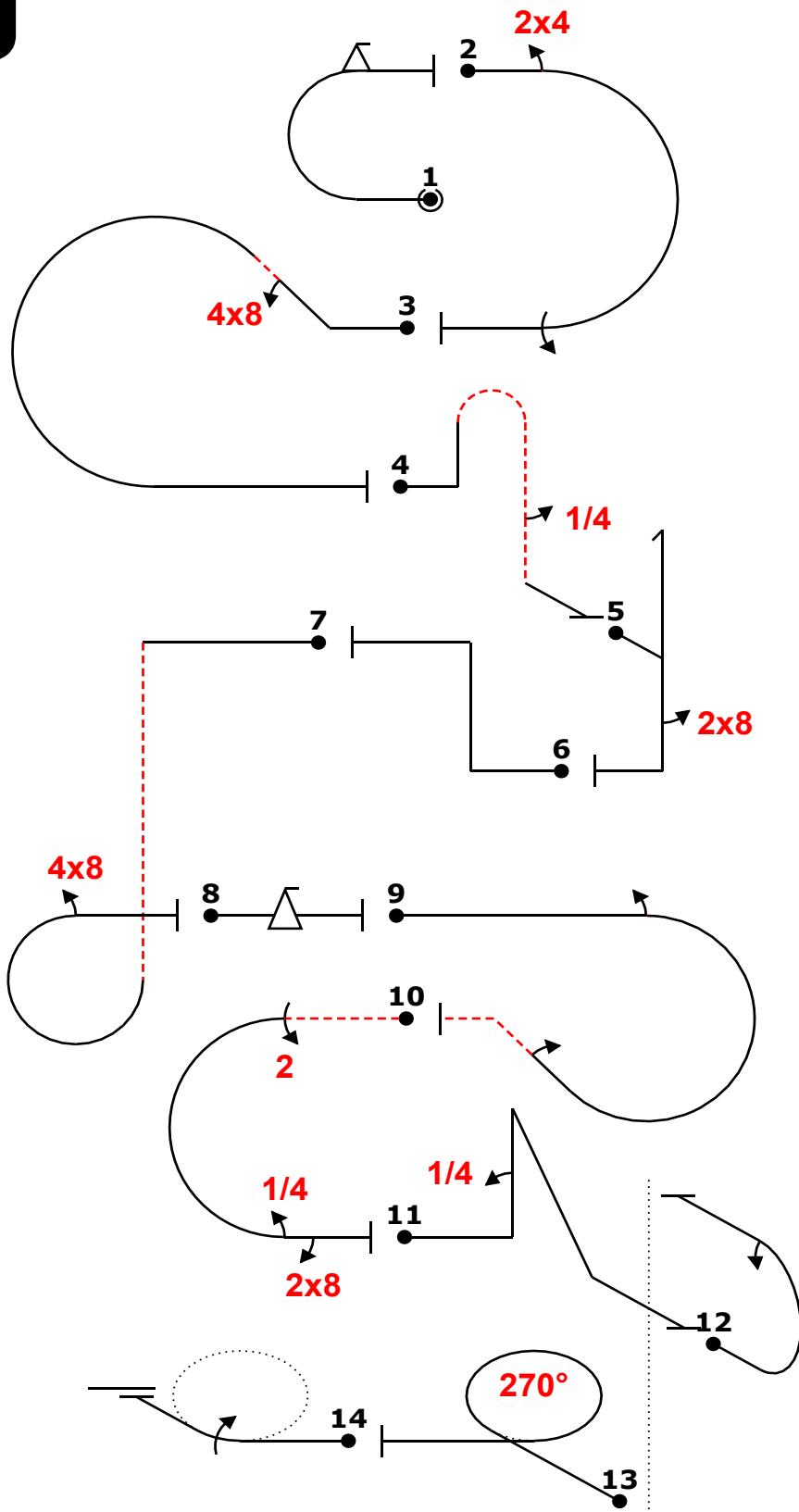

Fig	Grade	Pos	Remarks
1	.		
2	.		
3	.		
4	.		
5	.		
6	.		
7	.		
8	.		
9	.		
10	.		
11	.		
12	.		
13	.		
14	.		

Positioning **30**

Too Low		Trg Violation	
Too High		Wing Rocks	
Interruptions		Disqual Fig	
Insertions		Other(note...)	

ed "@A" /m2f "@C" 10% ``24a1+` "@I" 11% ``+` 48` ``rc+` ``@J` ``+` pb4 "@D" h8` "@L" ~v+ "@B" +
 +...irp48 "@H" f "@L" 6% ``2ic`,2` ``@F" 7% -22a4,8+` "@E" ~`4k` ``~` "@L" m2+~ [0,21] "@L" +
 +3j+ "@G" 1j>

Fig 1 A	K	Fig 2 C	K	Fig 3 I	K	Fig 4 J	K	Fig 5 D	K	Fig 6 L	K	Fig 7 B	K	Fig 8 H	K	Fig 9 L	K	Fig 10 F	K	Fig 11 E	K	Fig 12 L	K	Fig 13 L	K	Fig 14 G	K
7.2.2.1	6	7.2.3.3	6	8.5.2.1	10	8.4.3.1	15	5.2.1.1	17	1.1.6.1	10	8.6.4.3	13	1.1.1.1	2	8.5.8.3	11	7.2.1.4	6	1.2.6.1	14	7.2.2.1	6	2.3.1.1	5	2.1.3.1	14
9.9.3.2	11	9.4.3.2	5	9.8.2.2	9	9.1.5.1	2	9.8.5.1	3			9.8.3.2	7	9.9.3.4	11	9.1.3.2	4	9.2.3.4	9	9.1.1.1	6	9.1.3.2	4				
		9.1.3.4	8													9.1.2.2	6	9.1.3.1	2								
	17		19		19		17		20		6		20		13		6	9.8.3.1	3		20		6		6	14	

Pilot:

A/C:

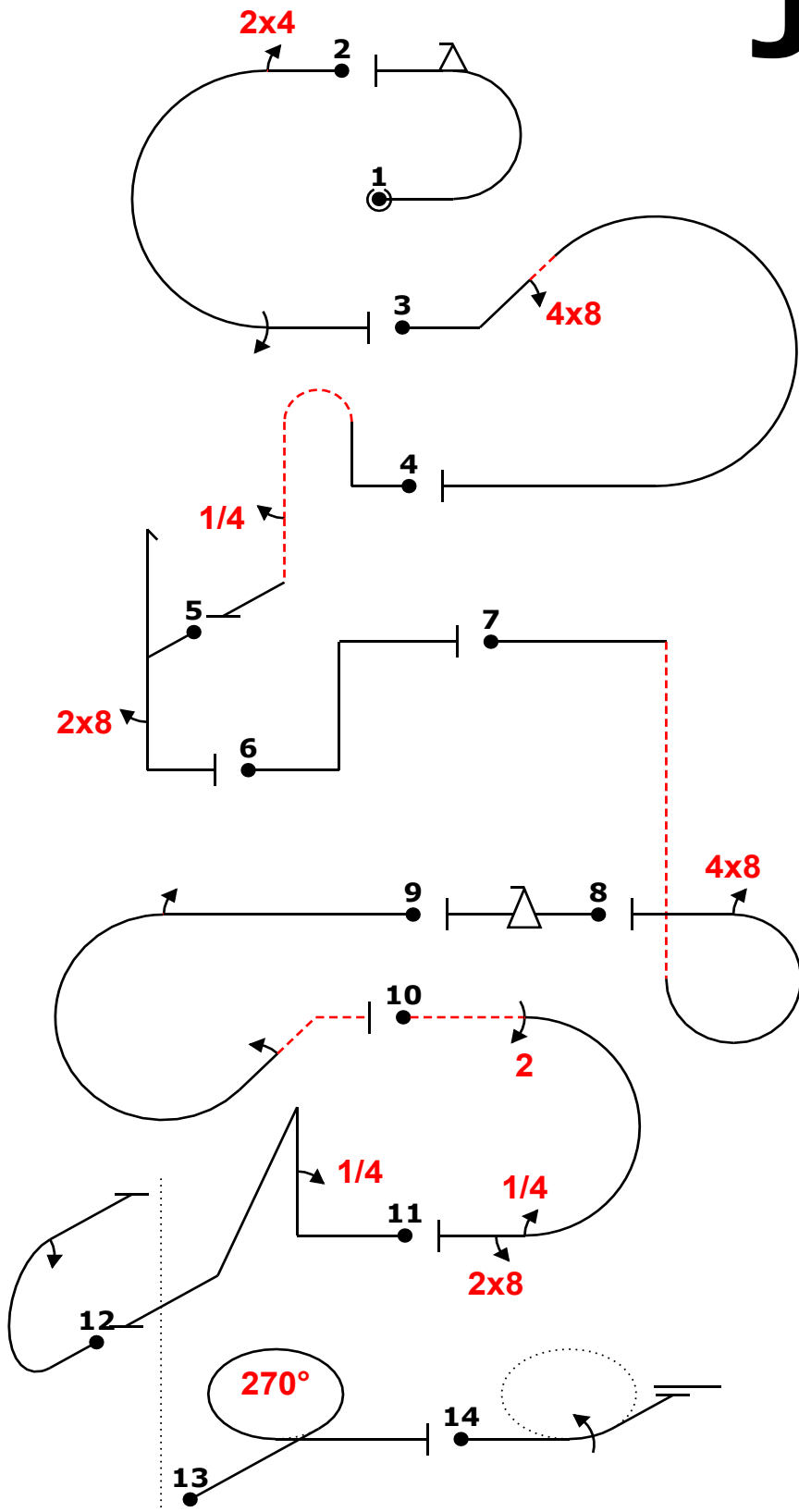
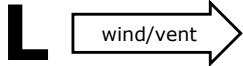

Fig	Grade	Pos	Remarks
1	.		
2	.		
3	.		
4	.		
5	.		
6	.		
7	.		
8	.		
9	.		
10	.		
11	.		
12	.		
13	.		
14	.		

Positioning	30	.
-------------	----	---

Too Low		Trg Violation	
Too High		Wing Rocks	
Interruptions		Disqual Fig	
Insertions		Other(note...)	

ed "@A" /m2f "@C" 10% `24a1+` "@I" 11% `+` "48" `rc+` "@J" `+` "pb4" "@D" h8' "@L" ~v+ "@B" +
 +...irp48 "@H" f "@L" 6% `2ic',2` "2" "@F" 7% -22a4,8+` "@E" ~`4k` ~+~ "@L" m2+~ [0,21] "@L" +
 +3j+ "@G" 1j1>

Fig 1 A	K	Fig 2 C	K	Fig 3 I	K	Fig 4 J	K	Fig 5 D	K	Fig 6 L	K	Fig 7 B	K	Fig 8 H	K	Fig 9 L	K	Fig 10 F	K	Fig 11 E	K	Fig 12 L	K	Fig 13 L	K	Fig 14 G	K
7.2.2.1	6	7.2.3.3	6	8.5.2.1	10	8.4.3.1	15	5.2.1.1	17	1.1.6.1	10	8.6.4.3	13	1.1.1.1	2	8.5.8.3	11	7.2.1.4	6	1.2.6.1	14	7.2.2.1	6	2.3.1.1	5	2.1.3.1	14
9.9.3.2	11	9.4.3.2	5	9.8.2.2	9	9.1.5.1	2	9.8.5.1	3			9.8.3.2	7	9.9.3.4	11	9.1.3.2	4	9.2.3.4	9	9.1.1.1	6	9.1.3.2	4				
		9.1.3.4	8													9.1.2.2	6	9.1.3.1	2								
	17		19		19		17		20		6		20		13		6		20		20		6		6		14

Pilot:

A/C: