

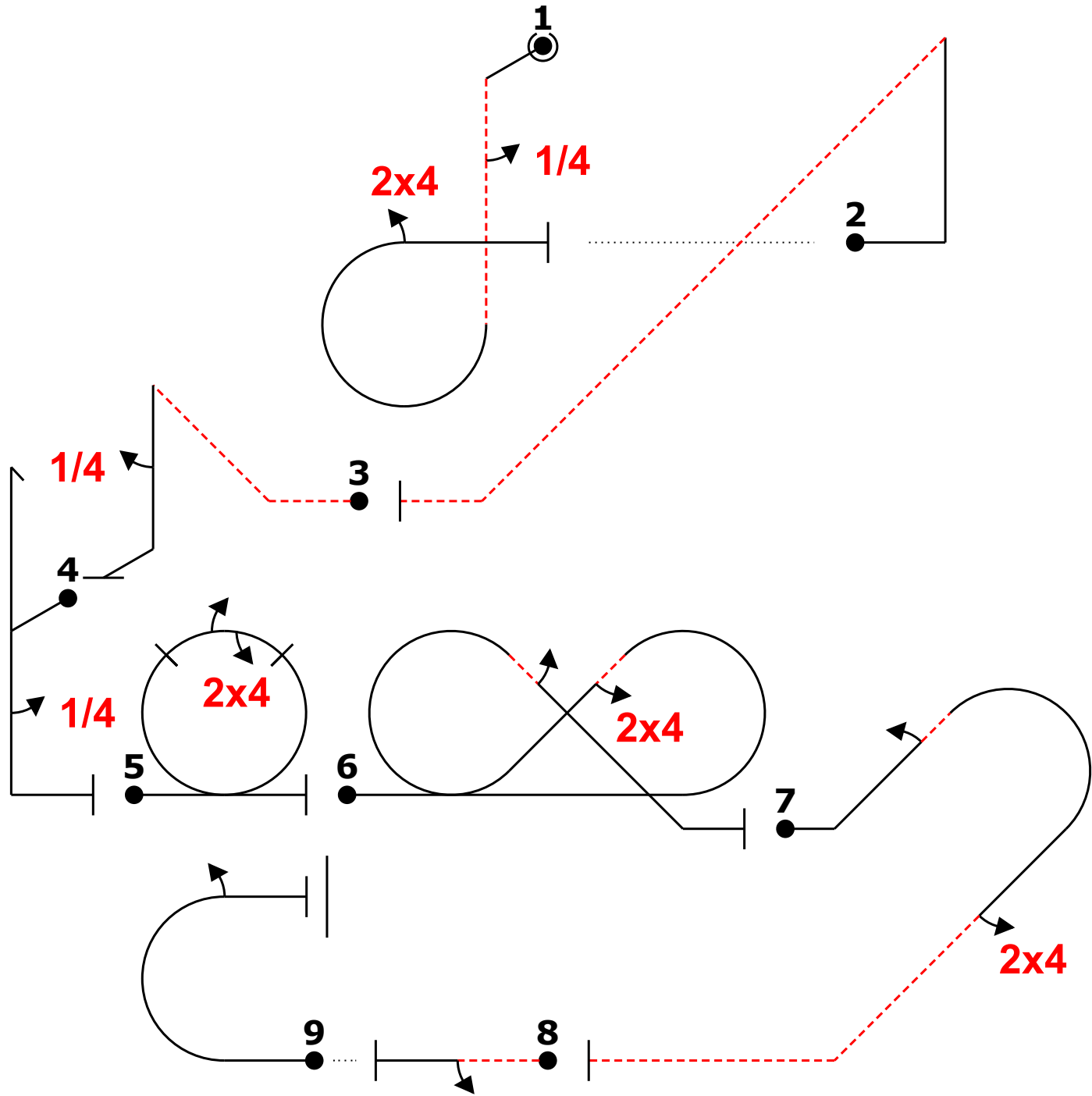

		Form B
Pilot ID	CIVA Glider Advanced Free	
	Flight #	

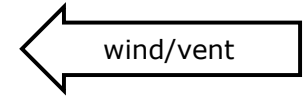

ej "@C" 4irp24~ (11,0) "@E" k.....' - "@L" -t,4 "@F" h4'' "@D" ""+o24,2+"" "@G" cc(24)2+"" "@B" ""+2rdb24...'' - "@L" -2 (1,0) "@A" m2

Paweł Mazur Pilot
S-1 Swift SP-3532 A/C



		Form B
Pilot ID	CIVA Glider Advanced Free	
	Flight #	

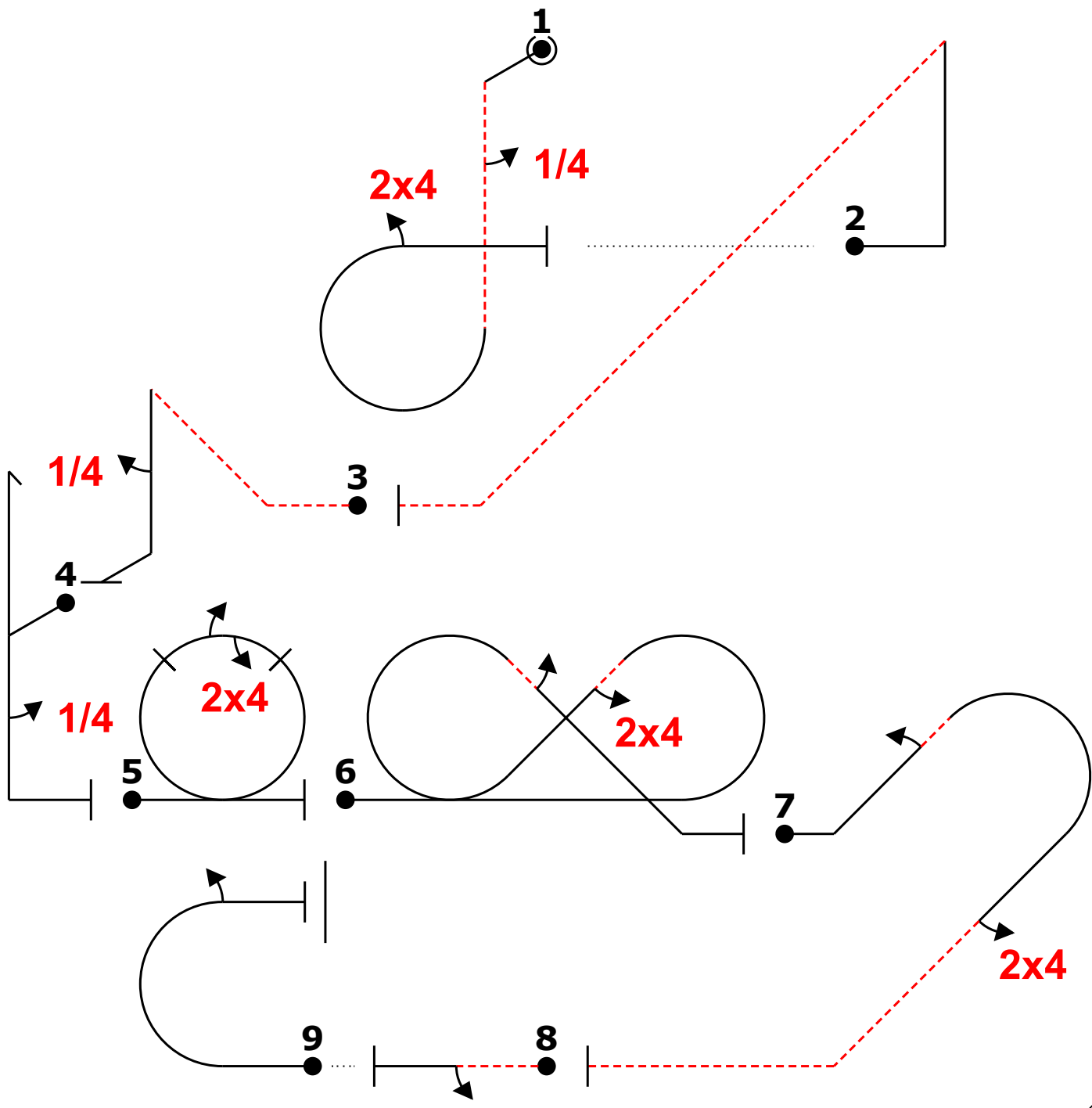
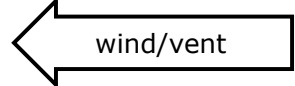

ej "@C" 4irp24~ (11,0) "@E" k.....' - "@L" -t,4 "@F" h4'' "@D" ""+o24,2+"" "@G" cc(24)2+"" "@B" ""+2rdb24...'' - "@L" -2 (1,0) "@A" m2

Agata Porebska Pilot
S-1 Swift SP-3532 A/C



		Form B
Pilot ID	CIVA Glider Advanced Programme 3	Flight #

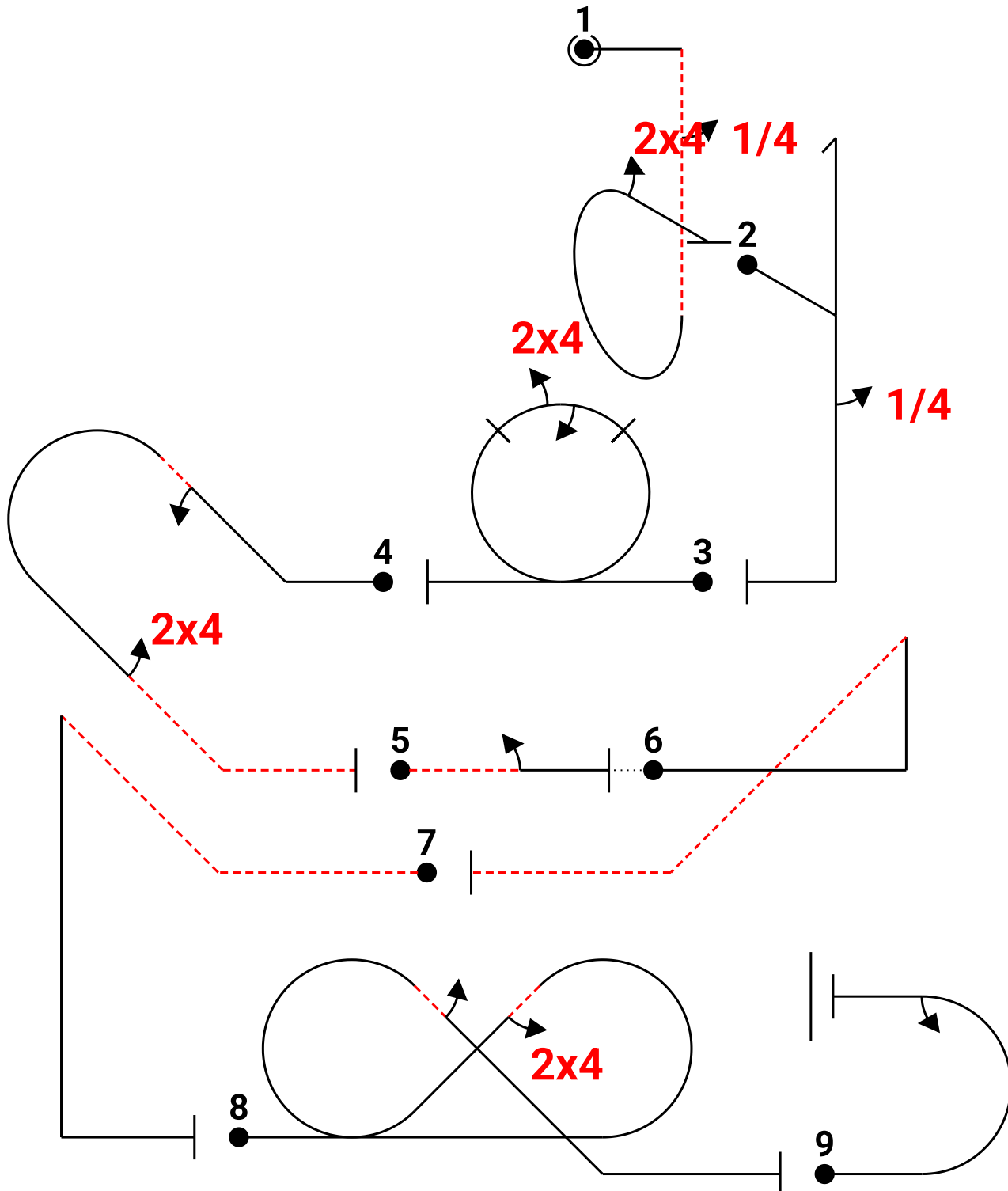
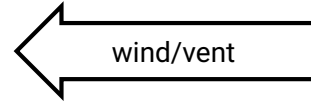

Björn Straljer Pilot
 MDM-1 Fox PH-1091 A/C



		Form B
Pilot ID	CIVA Glider Advanced Free	Flight #

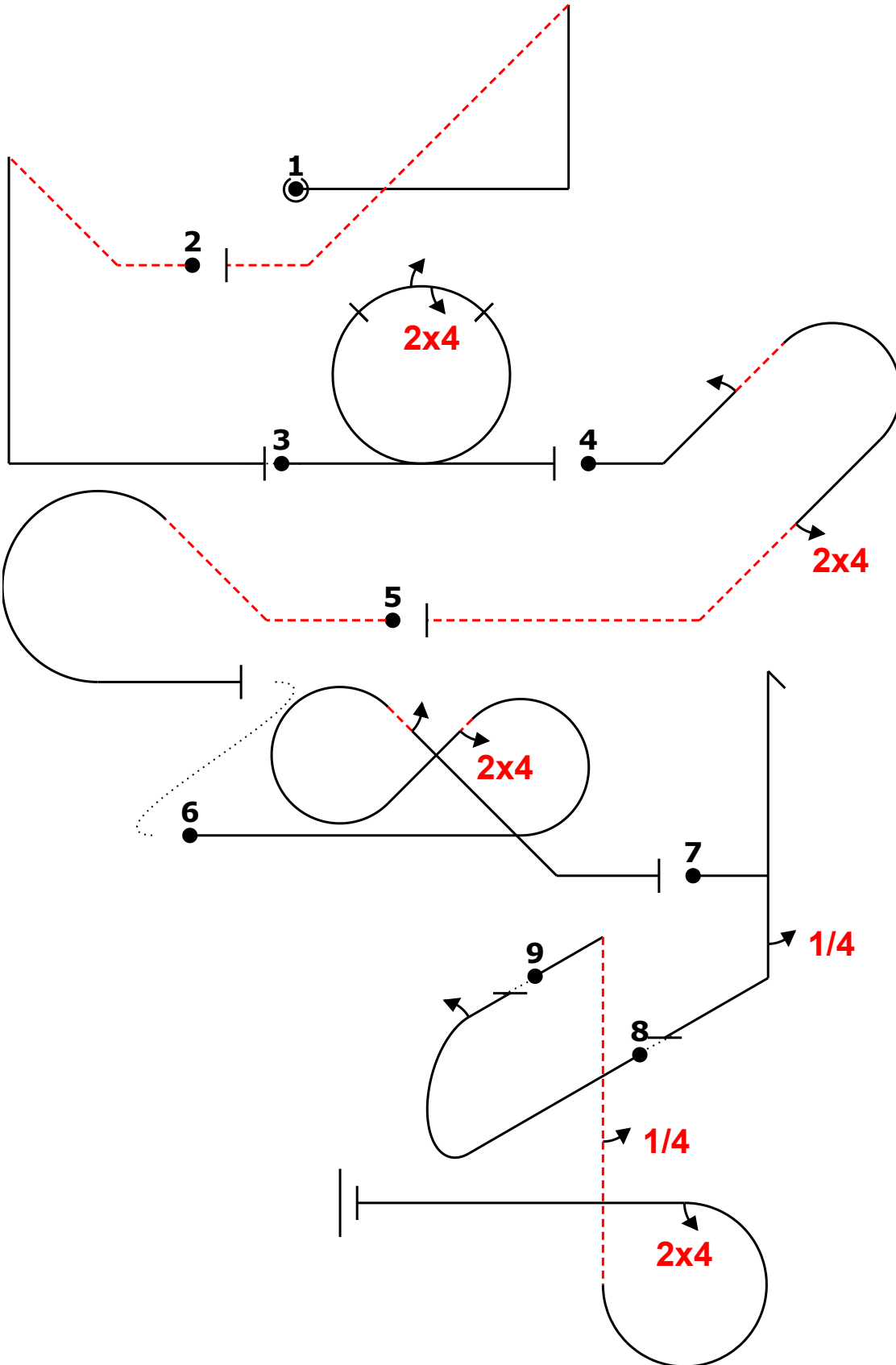
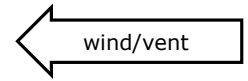

Glider			
Fig	Aresti	K	
1 E	1.2.5.1	14	14
2 Add.	1.2.2.2	13	5
3 D	7.4.1.1 9.4.3.2 9.1.3.2	10 8 6	24
4 B	8.4.16.1 9.1.2.2 9.4.4.2	14 9 8	31
5 Add.	8.5.1.2	10	5
6 G	7.8.4.1 9.4.4.2 9.1.4.2	19 8 6	33
7 F	5.2.1.1 9.1.5.1	17 3	20
8 A	7.2.2.1 9.1.3.2	6 6	12
9 C	8.6.4.3 9.1.5.1 9.4.3.2	13 3 8	24
Total K = 168 (max K = 180)			

2% "E" +++k' - "@L" - 't...'+~ (-3,0) "@D" 3% o24,2 "@B" 2' rdb'24...~ "@L" 4% ~~~~~rc+ ~~~~~ (-7,9) "@G" .cc(~~~~24)2'++
 "@F" .h4++ (2,-1) "@A"m2 (-2,1) "@C" 2% ~..4'irp24+++

Vilém Říha Pilot
 Swift S1 OK-2100 A/C



WAGAC Oschatz		Form B
Piloten ID	CIVA Glider Advanced Free	Flug #

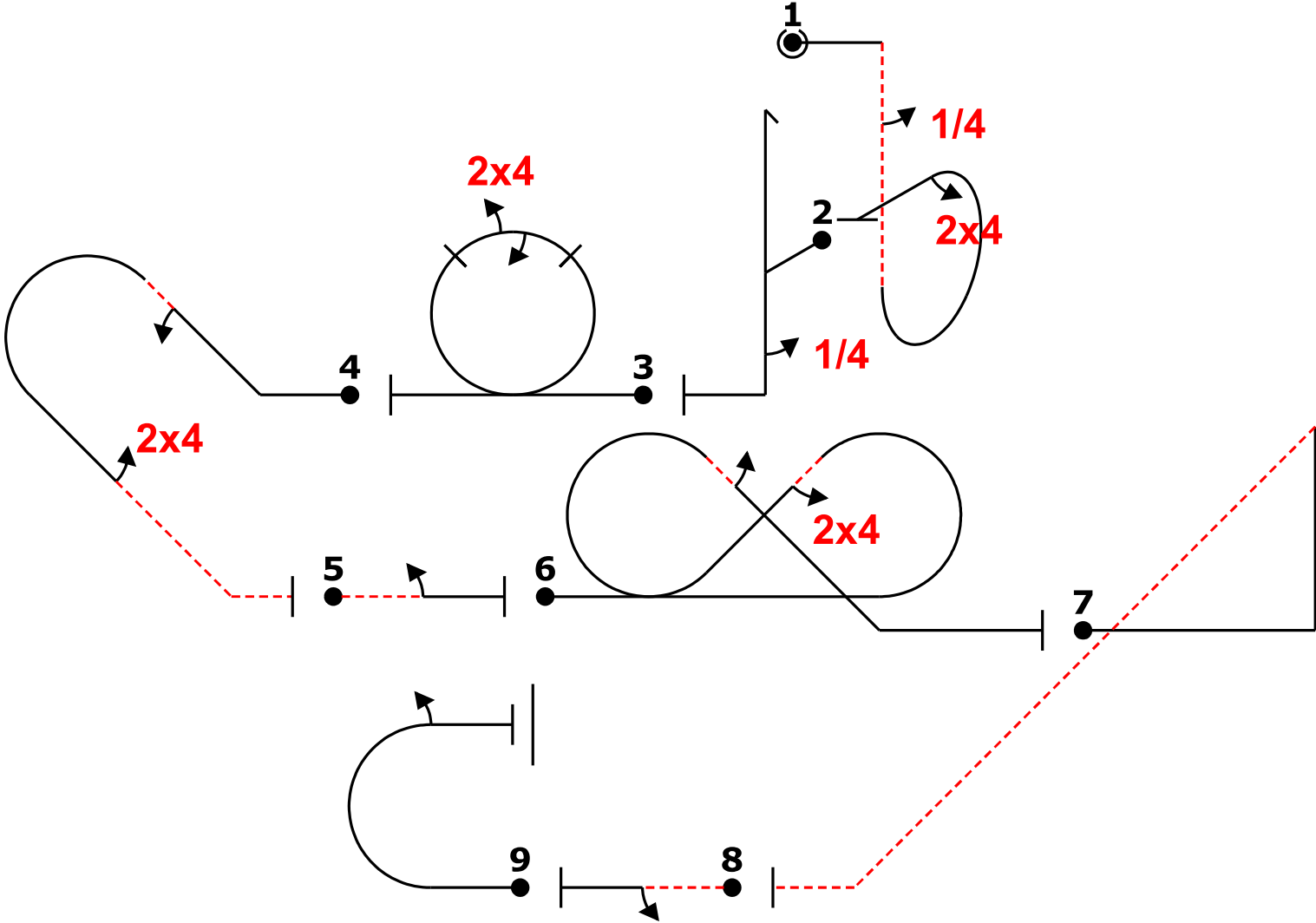
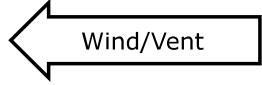

"@C" 4irp24 "@F" h4 "@D" o24,2 "@B" 2rdb24... "@L" -2 "@G" cc(24)2 "@E" ~++k.....' - "@L" -2 "@A" m2

Nick Weiss Pilot
 SZD-59 Acro D-598F Flugzeug



WAGAC Oschatz 2024		Form B
Pilot ID	CIVA Glider Advanced Free	Flight #

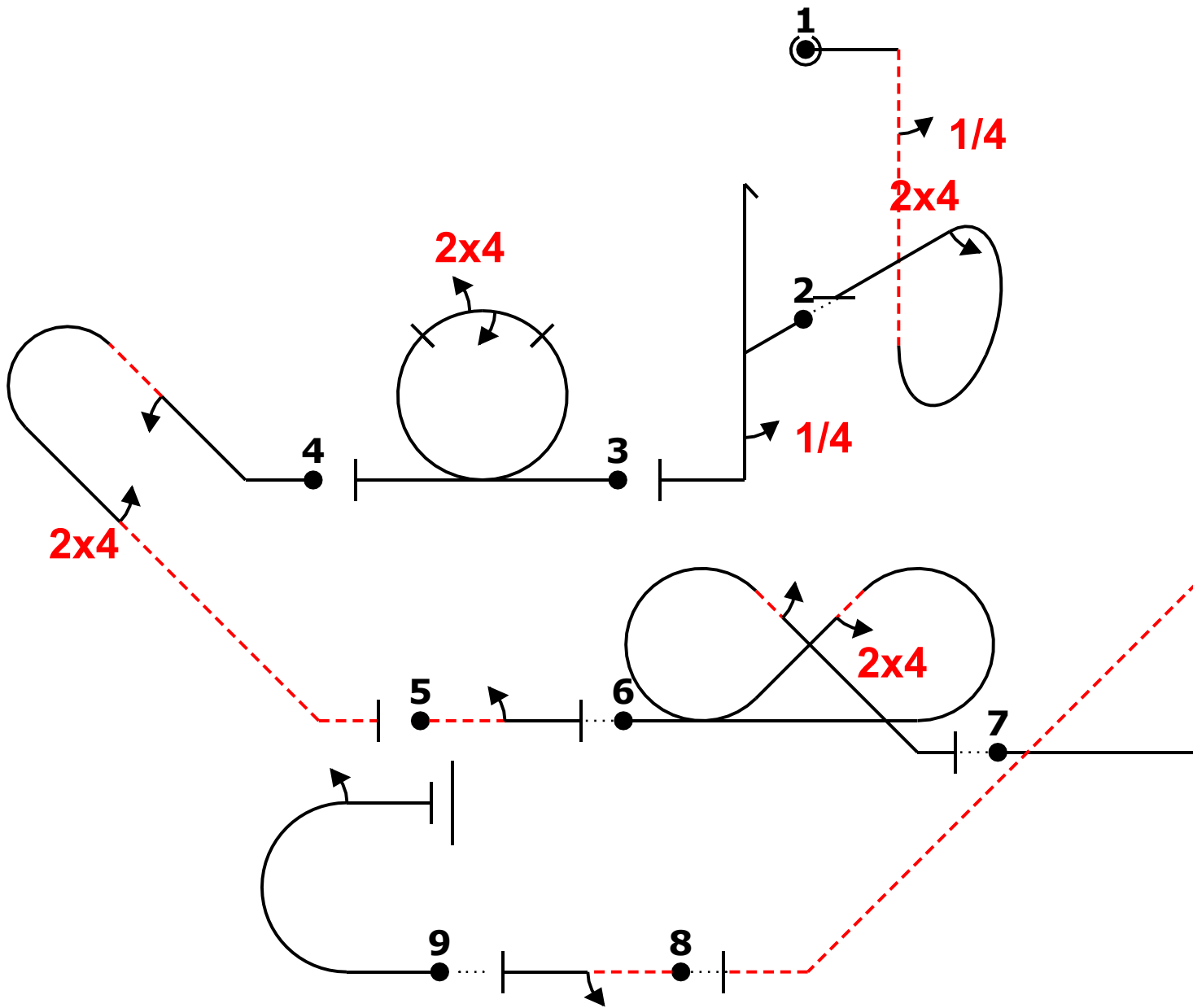
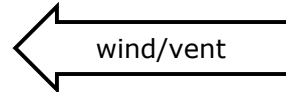

Lars Czernek Pilot
Swift S1 D-7125 A/C



2024 Known		Form B
Pilot ID	CIVA Glider Advanced Free	
	Flight #	

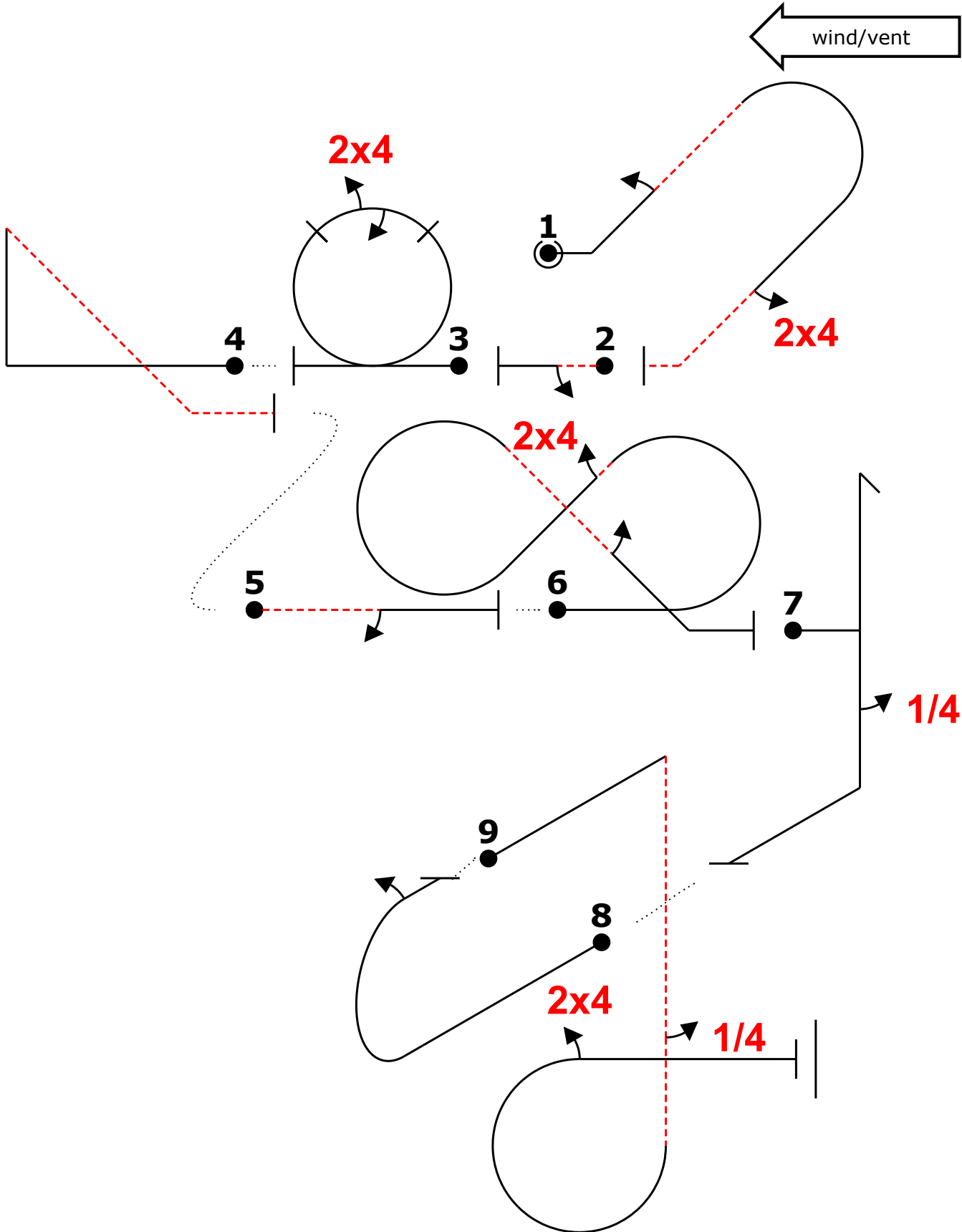

-1% "@B" ~~~+2. rdb'24. ~~~~~ "L" ~22' "@D" ~~~+o24,2+~~~"E" (1,0) -3% +++k. ~~~ (-5,10) "L" ~~~,2~ (-1,0) 1% "@G" ~~~~~
 cc(' ,24). ~~~|"2 ~~~~~ +~~~~ "@F" ~+h4' ~~~ (-3,2) "@A" ~...m2+~ (-1,1) 1% "@C" ~~~+...4 ~~~ irp24+~>

Claudio Brasaola
 Pilot
 Swift S1 OE-5707
 A/C



WAGAC / Oschatz 2024		Form B
Pilot ID	CIVA Glider Advanced Programme 3	Flight #

← wind/vent

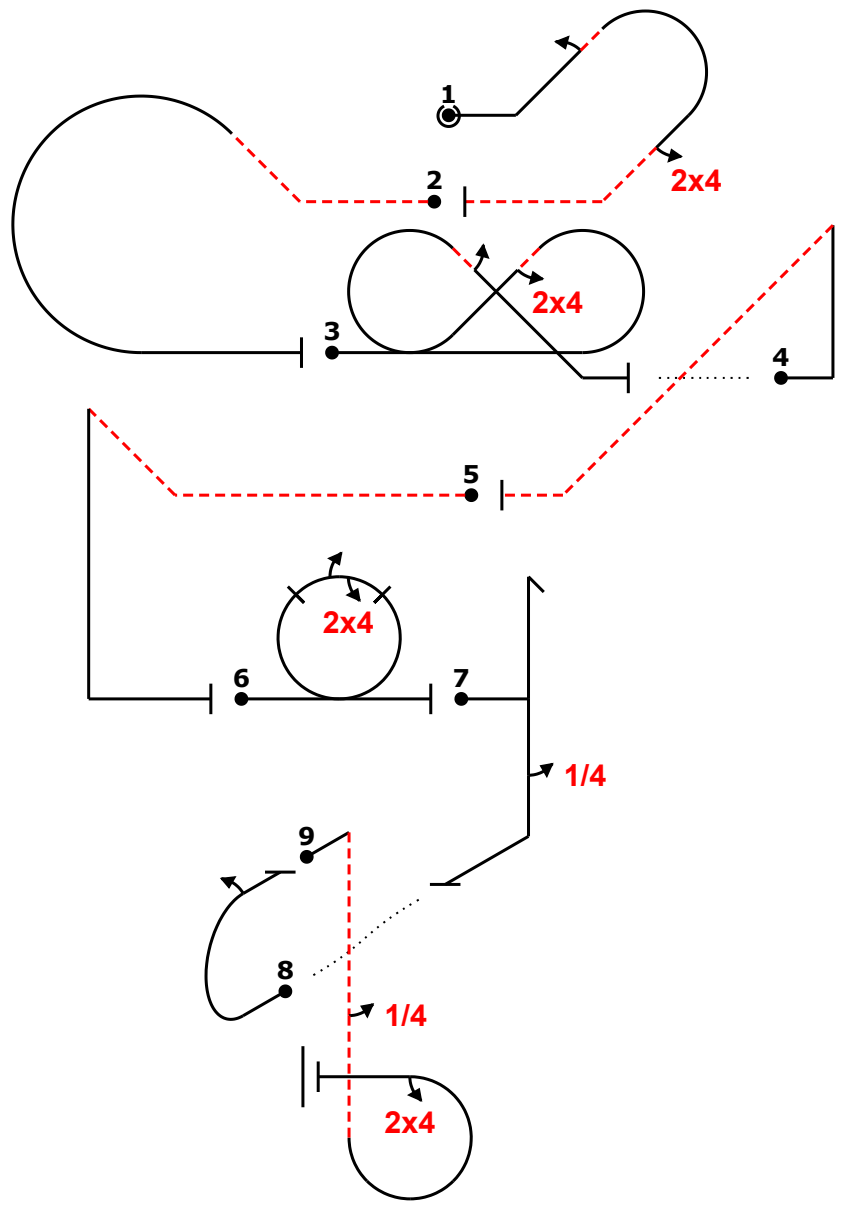

Glider			
Fig	Aresti	K	
1 B	8.4.16.1	14	31
	9.1.2.2	9	
	9.4.4.2	8	
2 Add.	8.5.1.2	10	5
3 G	7.8.4.1	19	33
	9.4.4.2	8	
	9.1.4.2	6	
4 E	1.2.5.1	14	14
5 Add.	1.2.2.2	13	5
6 D	7.4.1.1	10	24
	9.4.3.2	8	
	9.1.3.2	6	
7 F	5.2.1.1	17	20
	9.1.5.1	3	
8 A	7.2.2.1	6	12
	9.1.3.2	6	
9 C	8.6.4.3	13	24
	9.1.5.1	3	
	9.4.3.2	8	
Total K = 168		(max K = 180)	

@@ 2ndb 24. @L 11%rc+@G cc(24)2+ (6,0) @E "+k...- @L" -----t...'+- @0" o24,2 @F" h'4'+- (-7,5) @A" m2 @C" ...41rp24

Jan Rozivka Pilot
MDM1 FOX OK-4000 A/C



		Form B
Pilot ID	CIVA Glider Advanced Free	
		Flight #

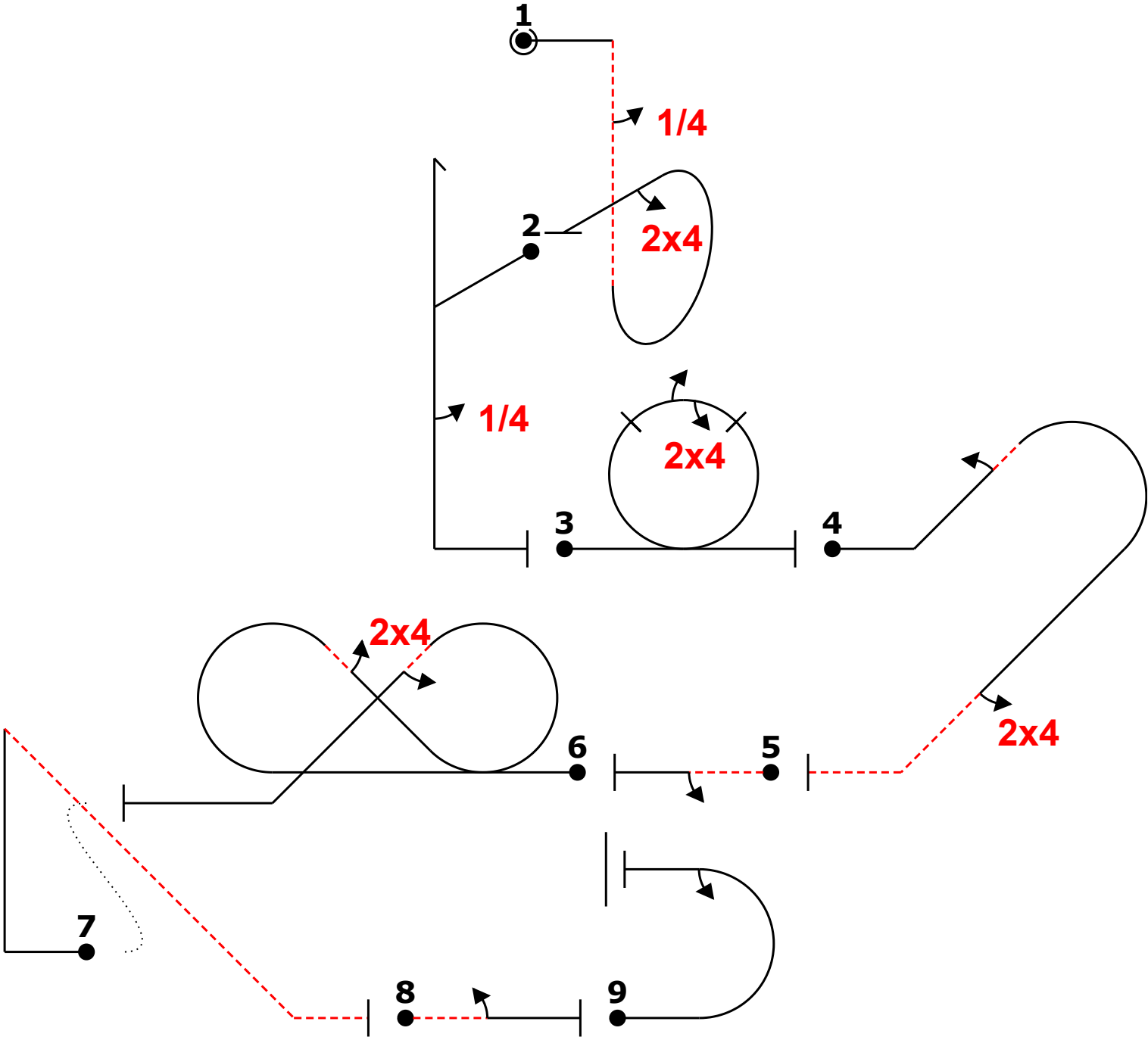
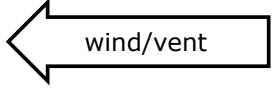

Geza Lazar Pilot
MDM-1 FOX YR-101c A/C



		Form B
Pilot ID	CIVA Glider Advanced Free	Flight #

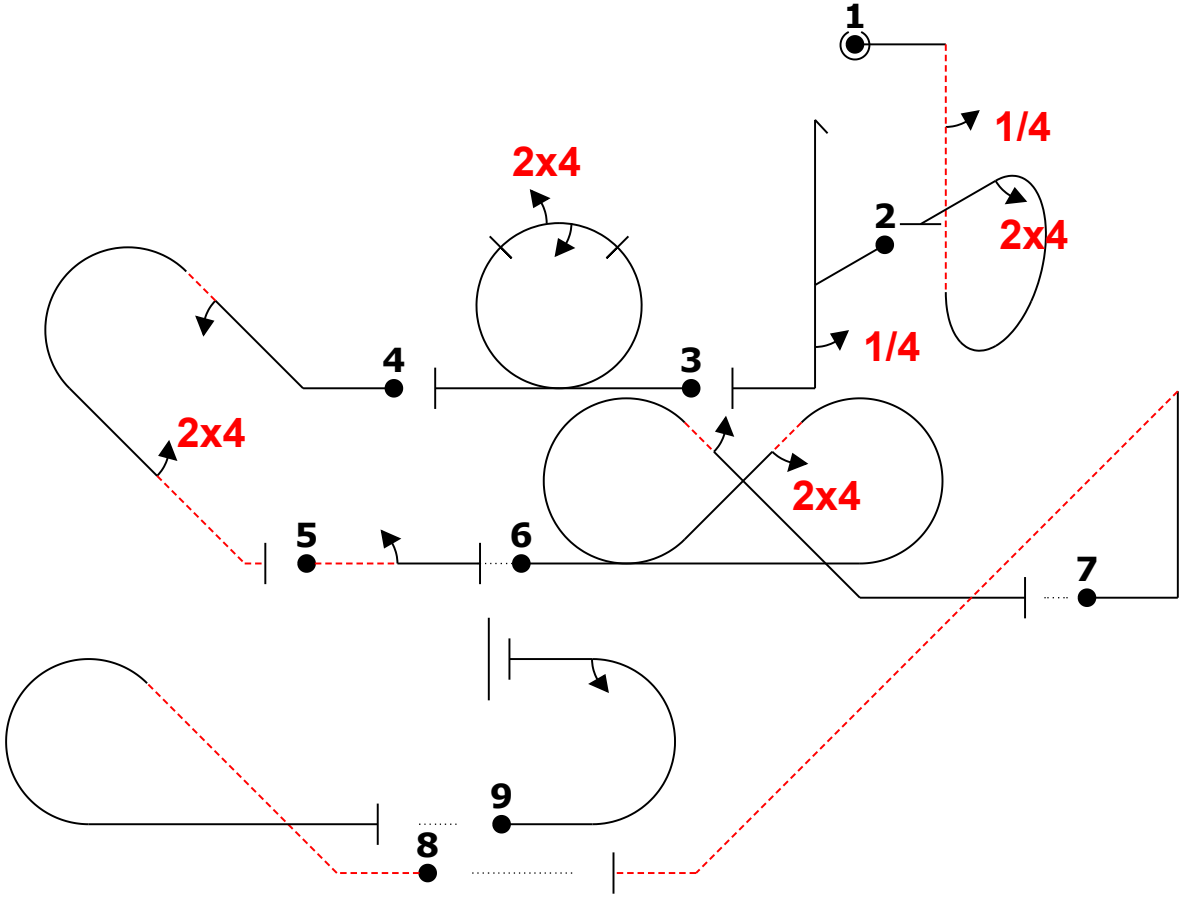
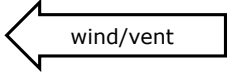

Glider			
Fig	Aresti	K	
1 C	8.6.4.3	13	24
	9.1.5.1	3	
	9.4.3.2	8	
2 F	5.2.1.1	17	20
	9.1.5.1	3	
3 D	7.4.1.1	10	24
	9.4.3.2	8	
	9.1.3.2	6	
4 B	8.4.16.1	14	31
	9.1.2.2	9	
	9.4.4.2	8	
5 Add.	1.1.1.4	2	5
	9.1.3.2	6	
6 G	7.8.4.1	19	33
	9.4.4.2	8	
	9.1.4.2	6	
7 E	1.2.5.1	14	14
8 Add.	8.5.1.2	10	5
9 A	7.2.2.1	6	12
	9.1.3.2	6	
Total K = 168 (max K = 180)			

"@C" 4irp24 "@F" ~h`4 "@D" o24,2 "@B" 2rdb24.'-..... "@L" -2 (-2,0) "@G" cc(24)2 (-1,0) "@E" k.....' (-5,0) "@L" -`rc (2,0) "@A" m2

Hendrik Fröhlich
 Pilot
 SZD59 D-5582
 A/C



		Form B
Pilot ID	CIVA Glider Advanced Free	
	Flight #	

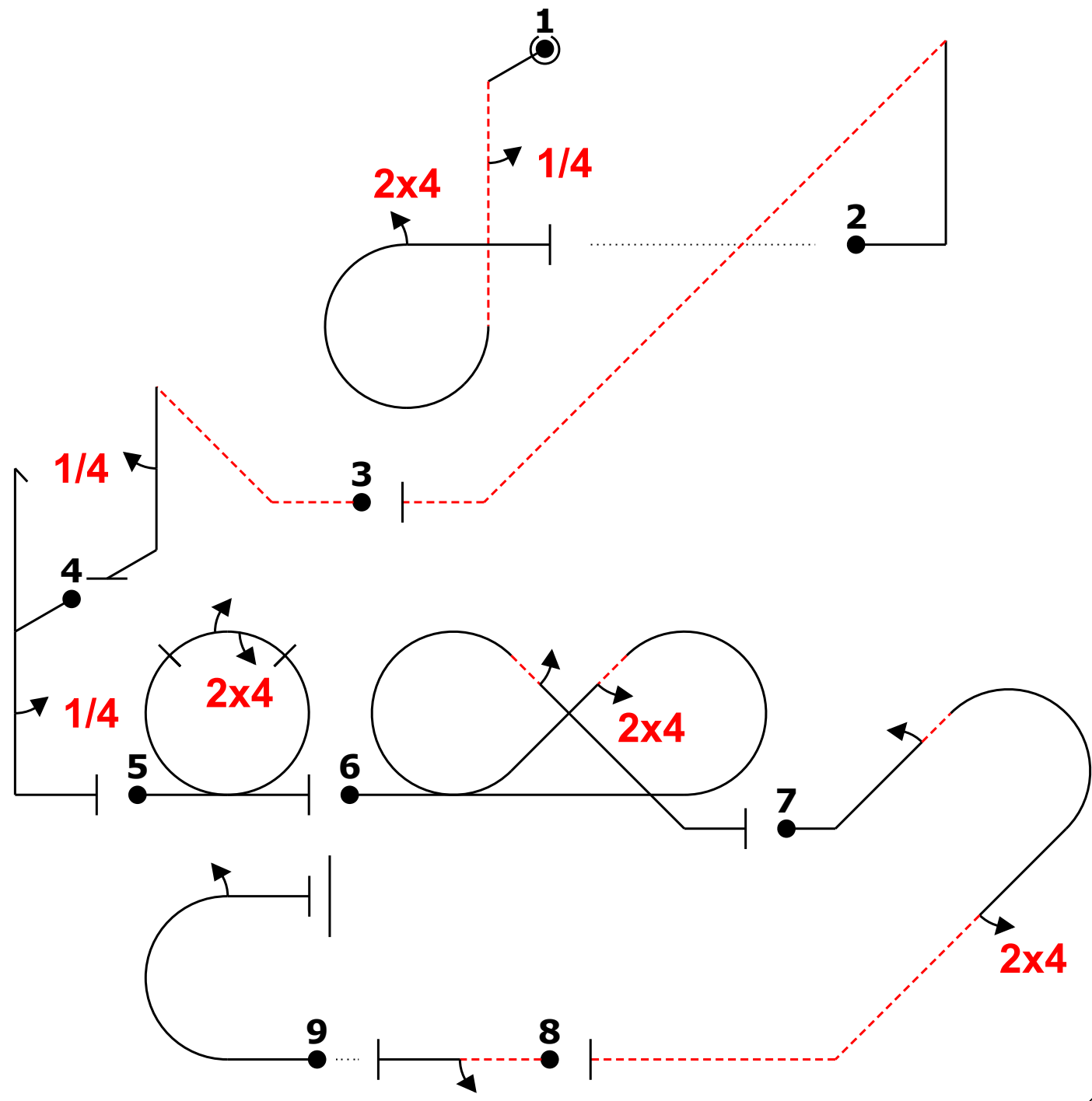
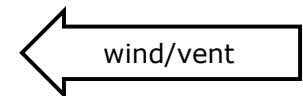

ej "@C" 4irp24~ (11,0) "@E" k.....' - "@L" -t,4 "@F" h4'' "@D" ""+o24,2+"" "@G" cc(24)2+"" "@B" ""+2rdb24...'' - "@L" -2 (1,0) "@A" m2

Piotr Sieradzan Pilot
S-1 Swift SP-3532 A/C



		Form B
Pilot ID	CIVA Glider Advanced Free	Flight #

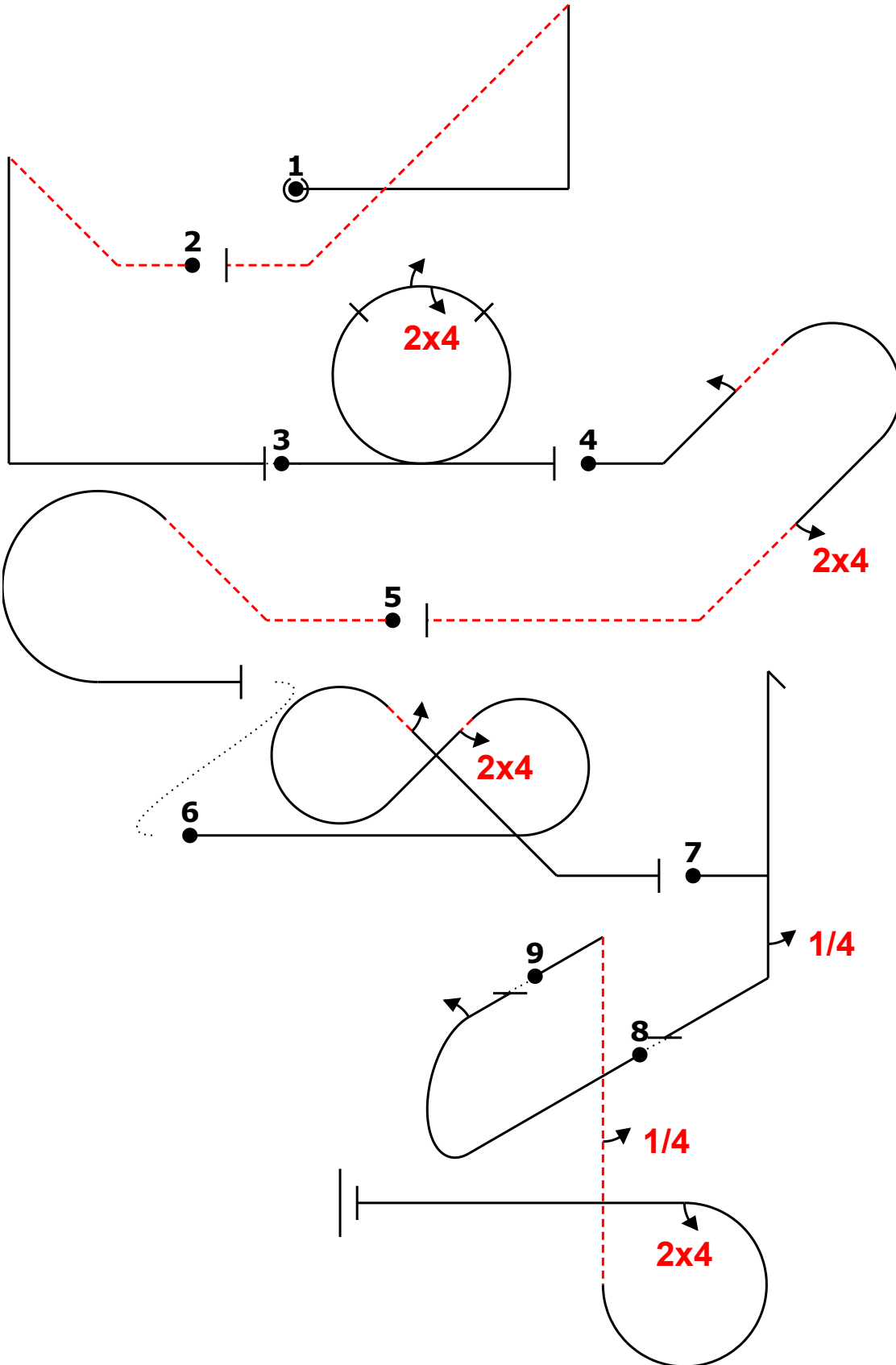
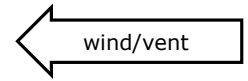

Glider			
Fig	Aresti	K	
1 E	1.2.5.1	14	14
2 Add.	1.2.2.2	13	5
3 D	7.4.1.1 9.4.3.2 9.1.3.2	10 8 6	24
4 B	8.4.16.1 9.1.2.2 9.4.4.2	14 9 8	31
5 Add.	8.5.1.2	10	5
6 G	7.8.4.1 9.4.4.2 9.1.4.2	19 8 6	33
7 F	5.2.1.1 9.1.5.1	17 3	20
8 A	7.2.2.1 9.1.3.2	6 6	12
9 C	8.6.4.3 9.1.5.1 9.4.3.2	13 3 8	24
Total K = 168 (max K = 180)			

2% "@E" +++`k'-' "@L" -'t...'+~ (-3,0) "@D" 3% o24,2 "@B" 2'`rdb'24...~ "@L" 4% ~~~~~rc+~~~~ (-7,9) "@G" .cc(~~~~24)2'++
"@F" .`h4++ (2,-1) "@A"m2 (-2,1) "@C" 2% ~..4'irp24+++

Marek Veselý Pilot
Swift S1 OK-2100 A/C



		Form B
Pilot ID	CIVA Glider Advanced Free	
	Flight #	

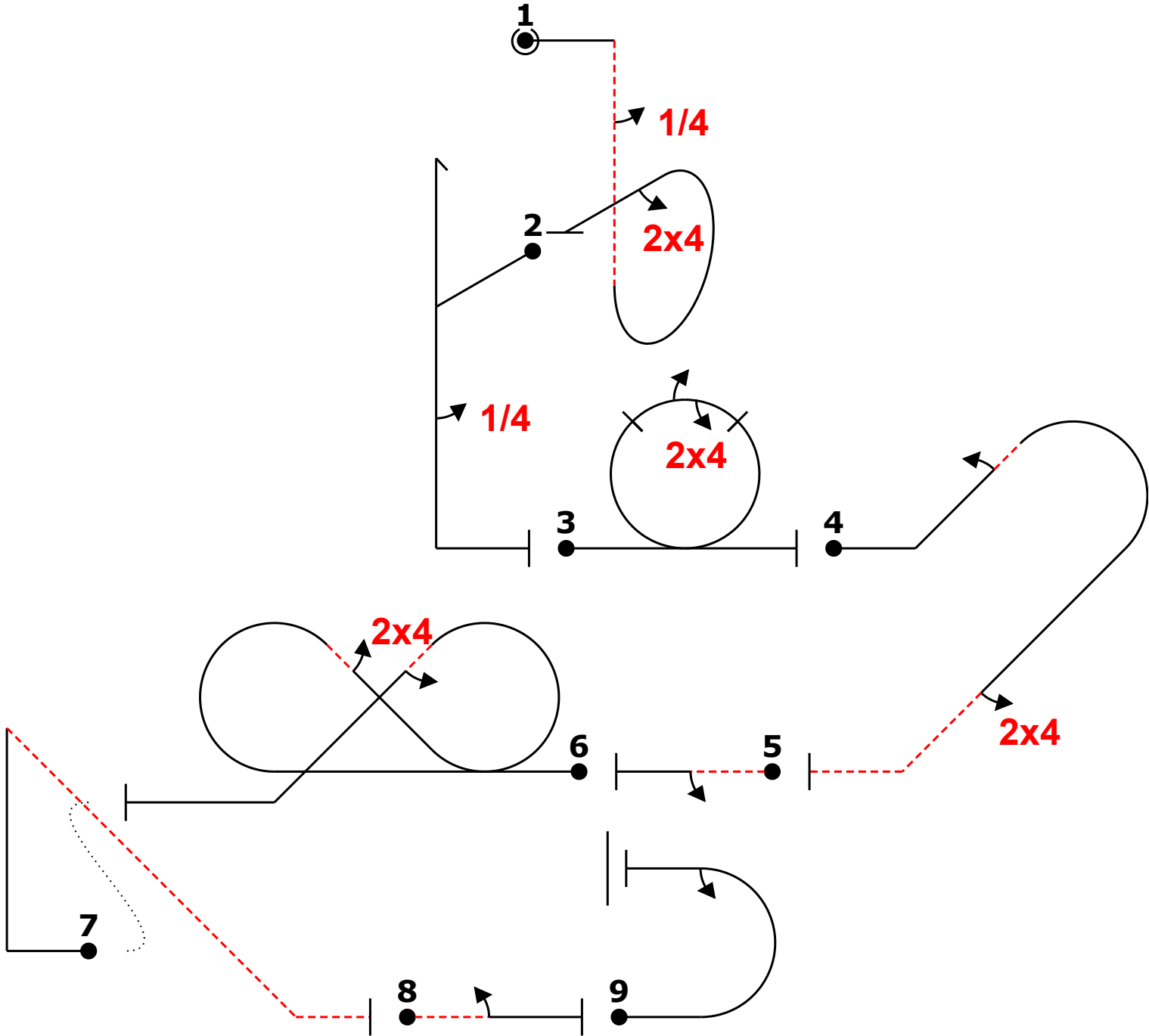
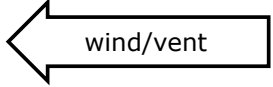

Valentin Hota Pilot
MDM-1 FOX YR-101c A/C



2024 Known		Form B
Pilot ID	CIVA Glider Advanced Free	Flight #

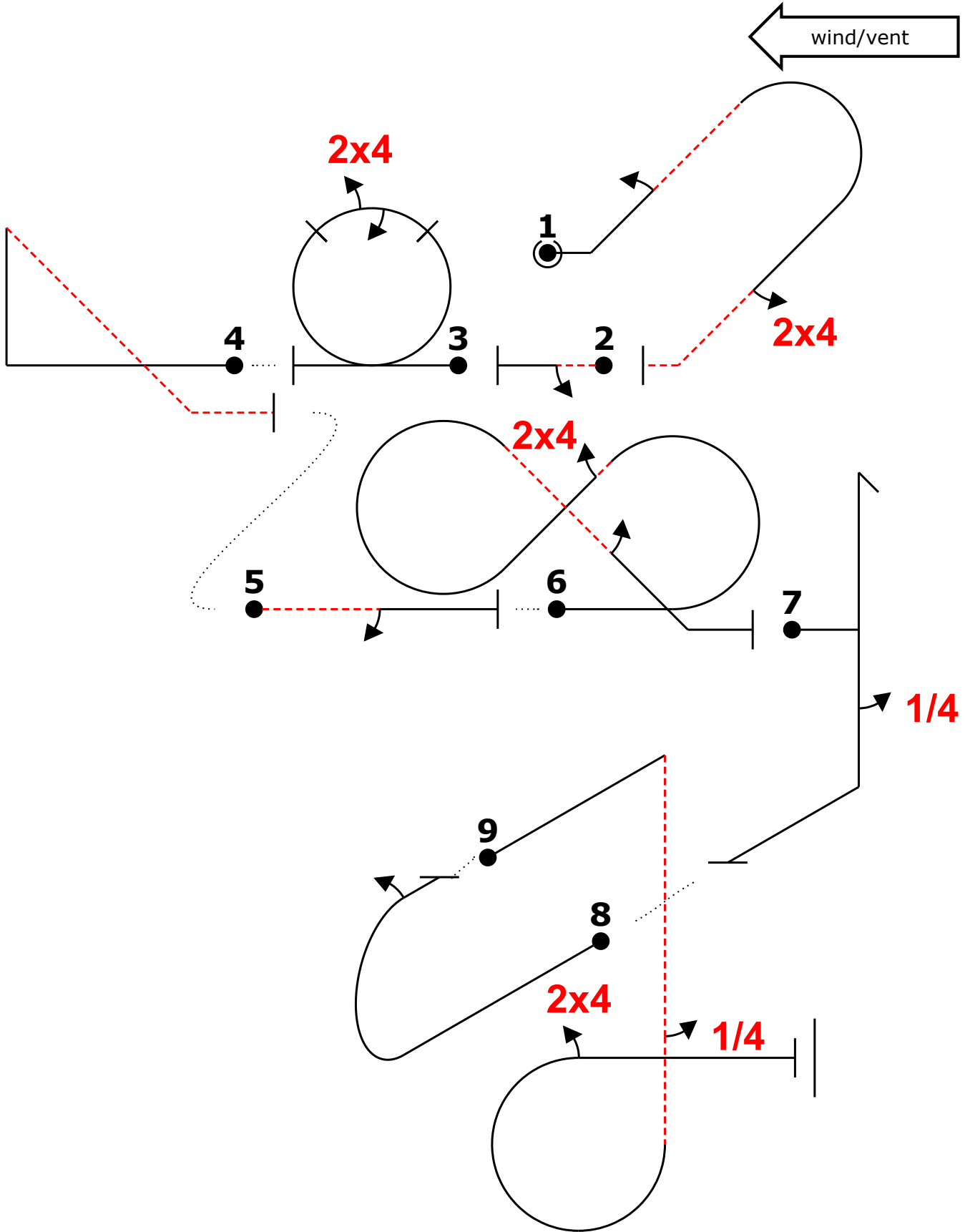

-1% "@B" ~~~+2. rdb'24.'-~~~~~ "L" -22' "@D" ~~~+o24,2+~~~"E" (1,0) -3% +++k.~ (5,10) "L" -' ,2~ (-1,0) 1% "@G" ~~~~~
 cc(' ,24) .'"|"2~~~~~ +~~~~~ "@F" ~+h4'++~ (-3,2) "@A" ~...m2+~ (-1,1) 1% "@C" +++...4~~~ irp24+~>

Daniele Meloni Pilot
 Swift S1 OE-5707 A/C



WAGAC Oschatz 01/08/2024		Form B
Pilot ID	CIVA Glider Advanced Free	Flight #

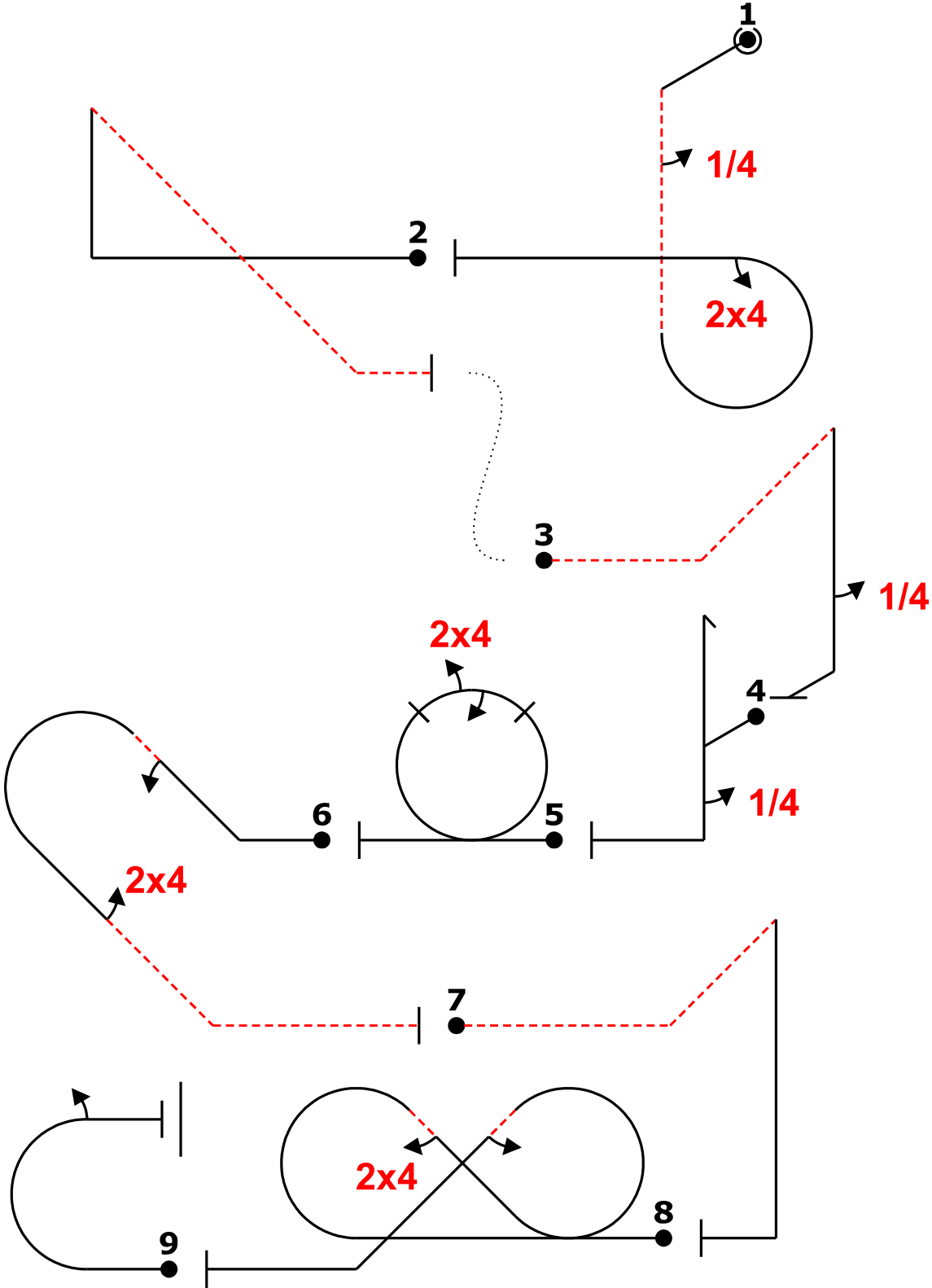
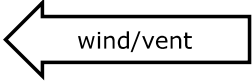

Glider			
Fig	Aresti	K	
1 C	8.6.4.3	13	24
	9.1.5.1	3	
	9.4.3.2	8	
2 E	1.2.5.1	14	14
3 Add.	1.2.2.2	13	5
	9.1.5.1	3	
4 F	5.2.1.1	17	20
	9.1.5.1	3	
5 D	7.4.1.1	10	24
	9.4.3.2	8	
	9.1.3.2	6	
6 B	8.4.16.1	14	31
	9.1.2.2	9	
	9.4.4.2	8	
7 Add.	1.2.2.2	13	5
8 G	7.8.4.1	19	33
	9.4.4.2	8	
	9.1.4.2	6	
9 A	7.2.2.1	6	12
	9.1.3.2	6	
Total K = 168 (max K = 180)			

ej "@C" +4'irp24+++> "@E" ~++++`k.- (2,10) "@L" ~---'t.'4 "@F" `h'4~ "@D" `'+o24,2 "@B" 2rdb24...` "@L" ~---t... "@G" /cc(,24)2 "@A" m2

Maximilien Godard
 Pilot
 Swift S-1 F-CHBA
 A/C



		Form B
Pilot ID	CIVA Glider Advanced Free	Flight #

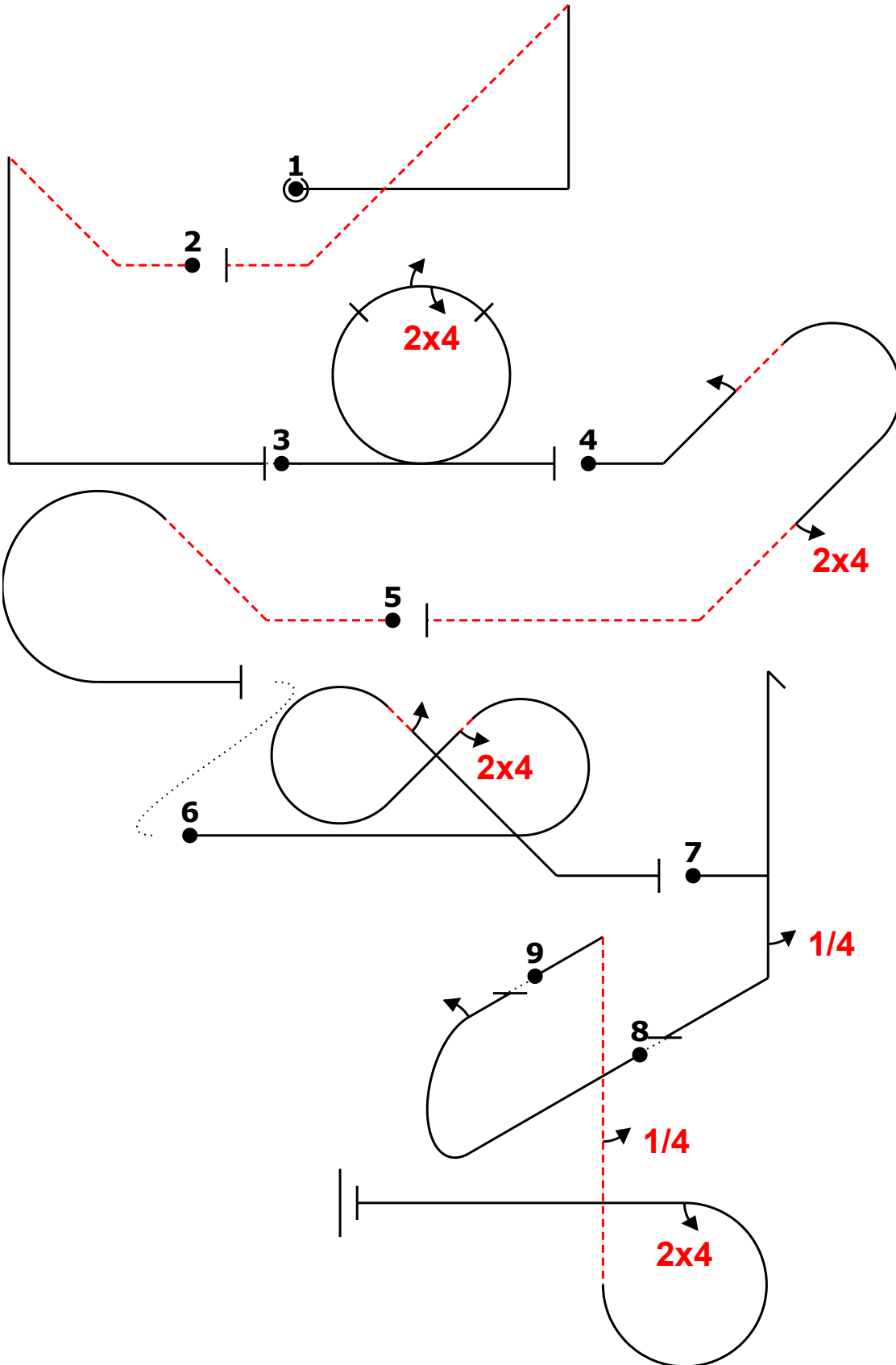
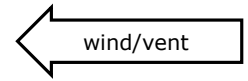

Glider			
Fig	Aresti	K	
1 E	1.2.5.1	14	14
2 Add.	1.2.2.2	13	5
3 D	7.4.1.1 9.4.3.2 9.1.3.2	10 8 6	24
4 B	8.4.16.1 9.1.2.2 9.4.4.2	14 9 8	31
5 Add.	8.5.1.2	10	5
6 G	7.8.4.1 9.4.4.2 9.1.4.2	19 8 6	33
7 F	5.2.1.1 9.1.5.1	17 3	20
8 A	7.2.2.1 9.1.3.2	6 6	12
9 C	8.6.4.3 9.1.5.1 9.4.3.2	13 3 8	24
Total K = 168 (max K = 180)			

2% "E" +++k' - "@L" - 't...'+~ (-3,0) "@D" 3% o24,2 "@B" 2' rdb'24...~ "@L" 4% ~~~~~rc+~~~~ (-7,9) "@G" .cc(~~~24)2'++
 "@F" .h4++ (2,-1) "@A"m2 (-2,1) "@C" 2% ~..4'irp24+++

Adam Klenka Pilot
 Swift S1 OK-2100 A/C



WAGAC/Oschatz 02.08.2024		Form B
Piloten ID	CIVA Glider Advanced Programme 3	
	Flug #	

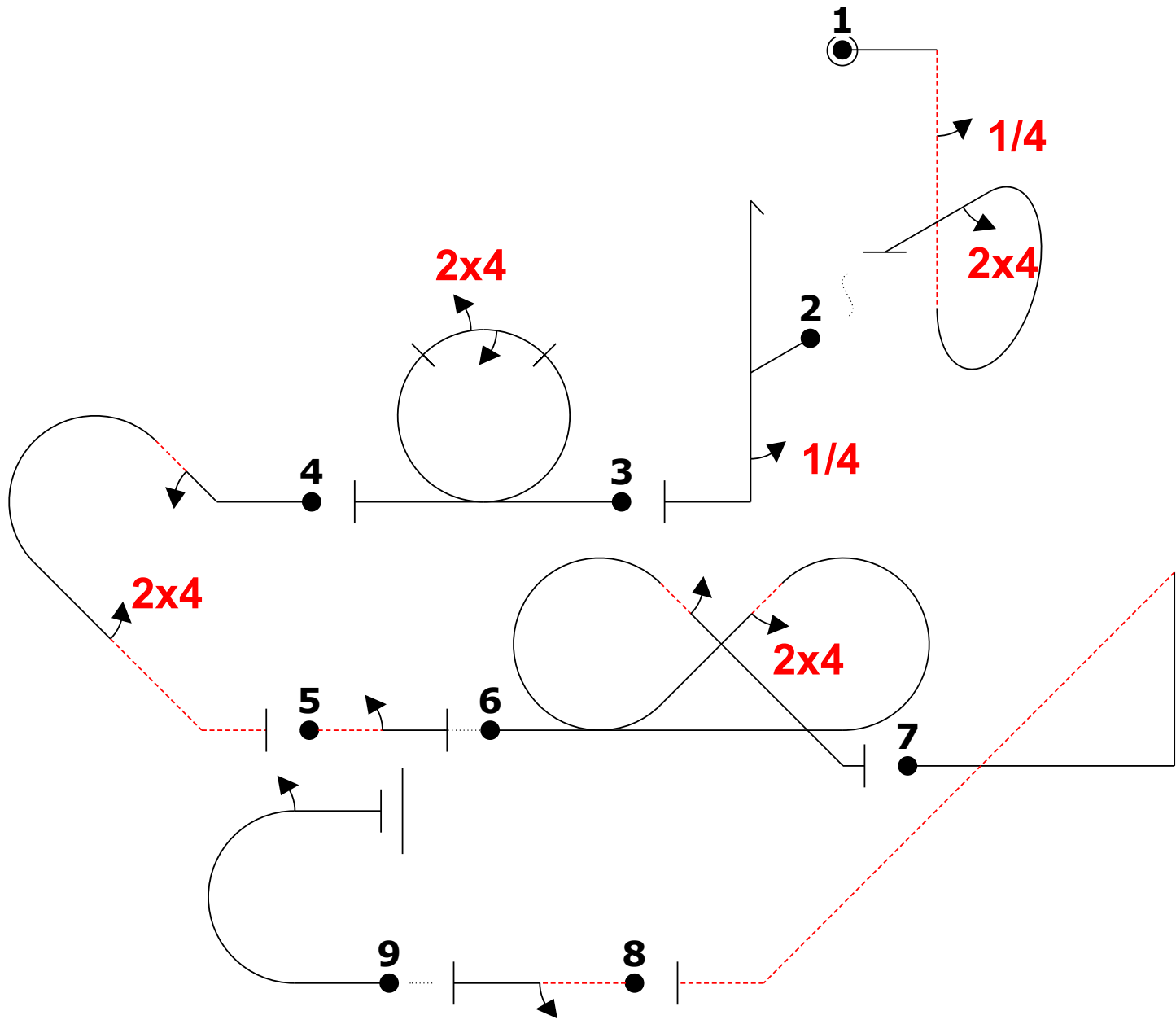
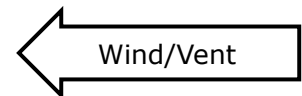

"@C" 4irp'24 (0,2) "@F" h4 "@D" o24,2 "@B"2rdb'24.'..... "@L" -'2'~ (-2,0) "@G" cc(24)2+..... "@E" ~~+
+k..... "@L" -2 (1,0) "@A" m2

Ines Pfabe Pilot
MDM-1 FOX D-6660
Flugzeug



		Form B
Pilot ID	CIVA Glider Advanced Programme 3	Flight #

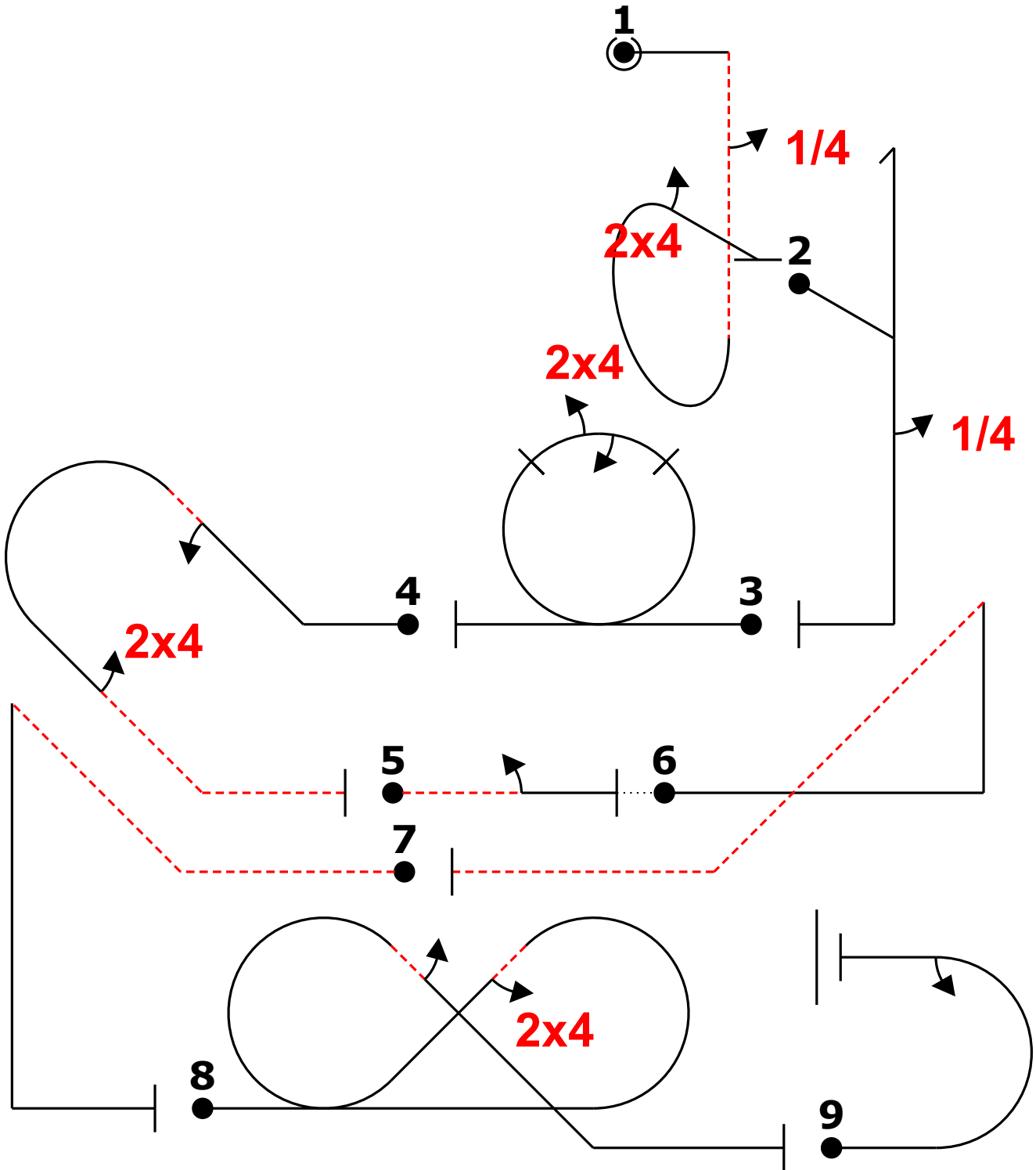

"@C" /4irp|"24 "@F" --h4.. "@D" o24,2 "@B" 2rdb`24.'-~~~~~ "@L" -'2 (-2,0) "@E" +++`x--- "@L" -----'t....-- "@G" cc(24)2
 "@A" m2

Lars Hofman Pilot
 MDM-1 Fox PH-1091 A/C



WAGAC Oschatz 2024		Form B
Pilot ID	CIVA Glider Advanced Free	Flight #

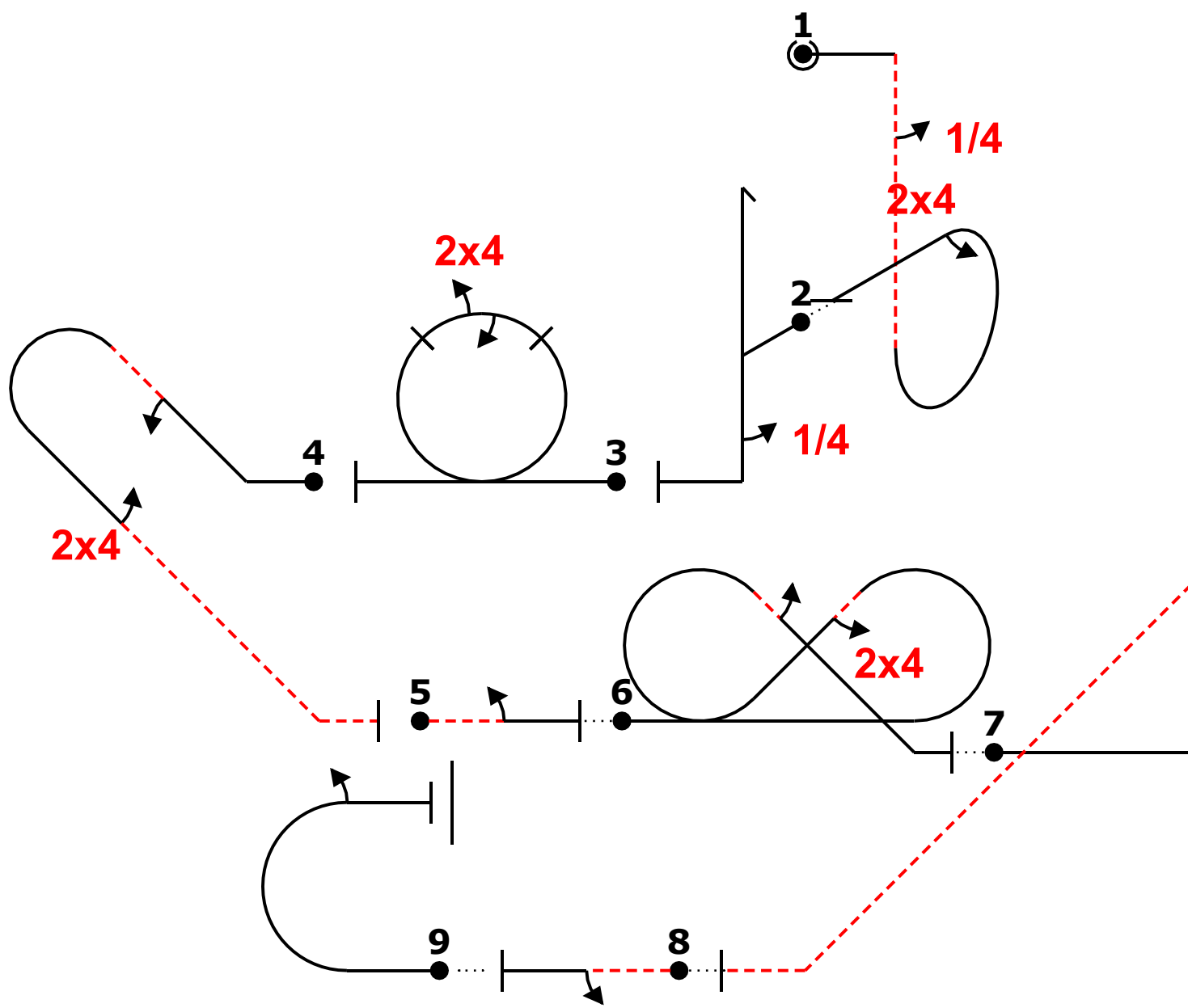
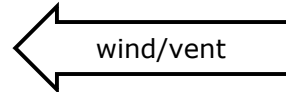

Nora Geusen Pilot
SZD-59 D-6668 A/C



		Form B
Pilot ID	CIVA Glider Advanced Unknown 4	Flight #

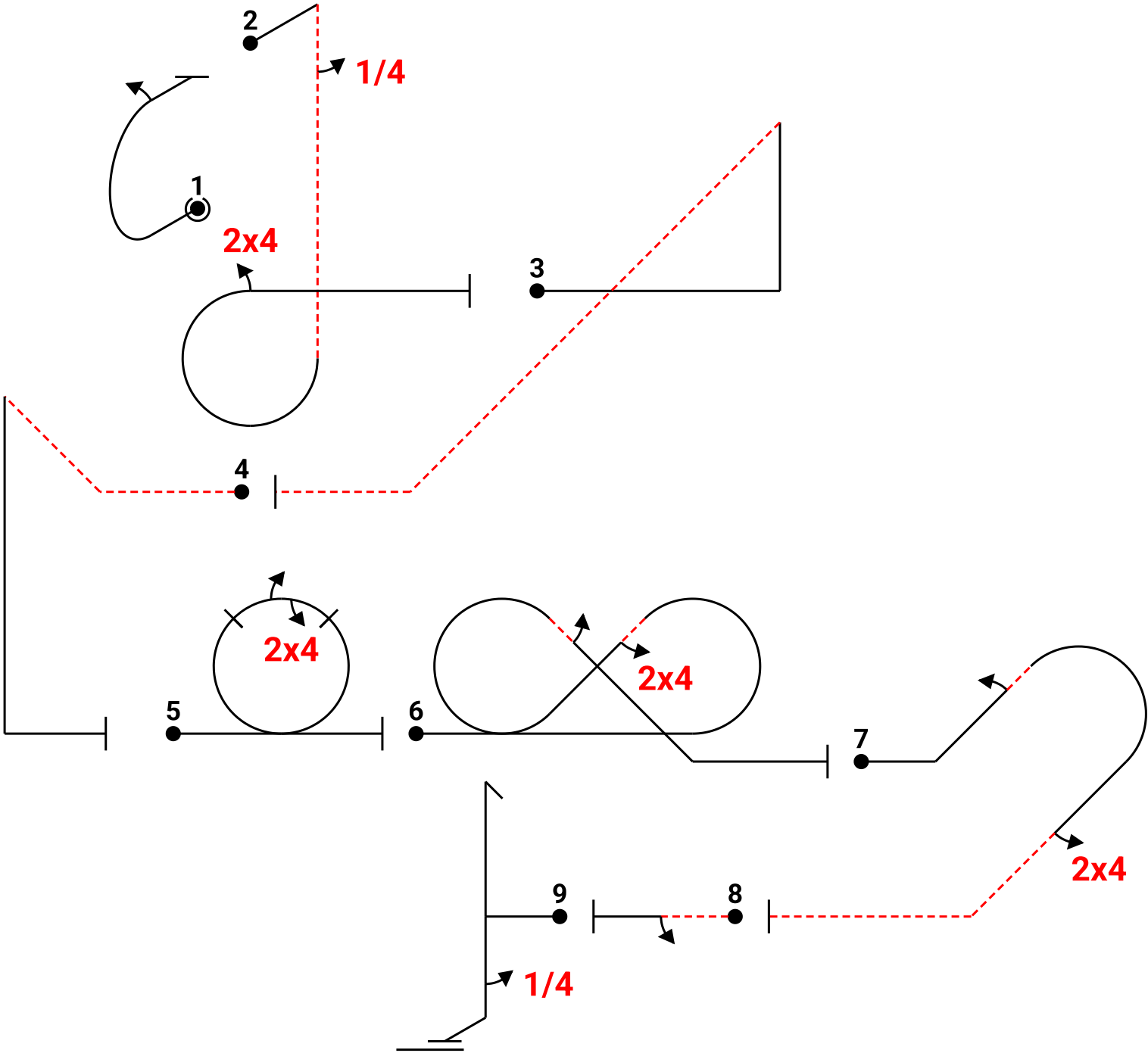
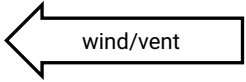

ej "@A" m2 (0,0) "@C" ~4...irp24+++ (0,0) "@E" ~+++k.....-- "@L" ~-t.....~ (0,0) "@D" o24,2 "@G" cc(24)2 "
 @B" 2rdb24.''- "@L" -2 "@F" h4

Takashi Sakai Pilot
 A/C



		Form B
Pilot ID	CIVA Glider Advanced Free	Flight #

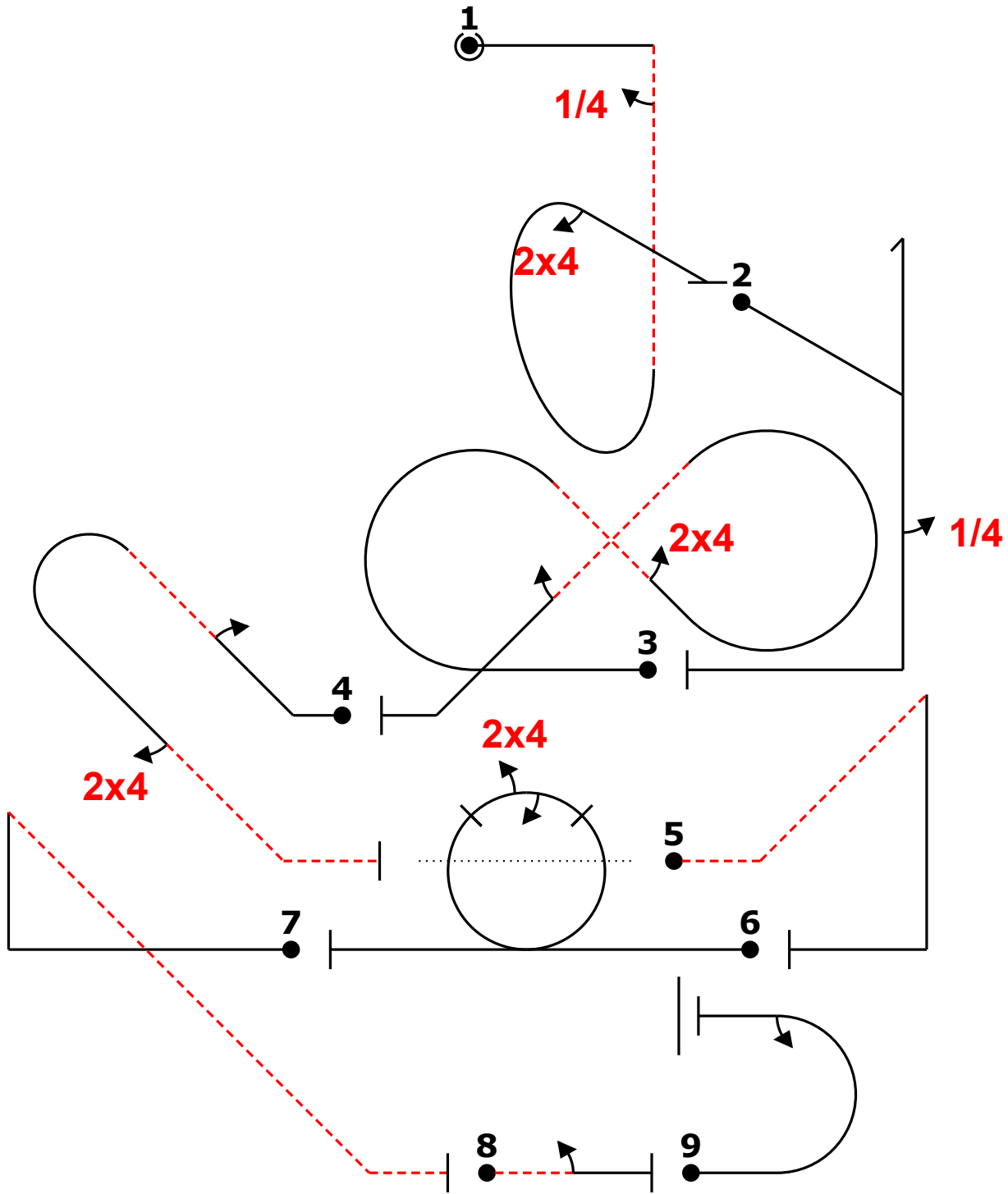
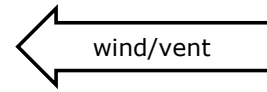

5% "eC" / ~ ~ ~ , 4' irp, 24 ~ "eF" +++ h. 4. ' ' + ~ "eG" 4% ~ ~ ~ ~ ~ + cc (. 24 ~ ~ ~) . ' , 2 ~ ~ ~ + ~ ~ ~ ~ ~ "eB" - 3% ~ ~ ~ + ' , 2 . . ' rdb . . , 24 . . . ' - ~ ~ ~ ~ ~ (11 , 0) "eL" - . ' t . ' ' + "eD" ~ ~ + o 24 , 2 ~ ~ "eE" ~ ~ + + ~ ~ k . . ' - "eL" - 2 "eA" m 2

Brigitte Danzinger
 Pilot
 Fox D-4560
 A/C



		Form B
Pilot ID	CIVA Glider Advanced Free	
	Flight #	

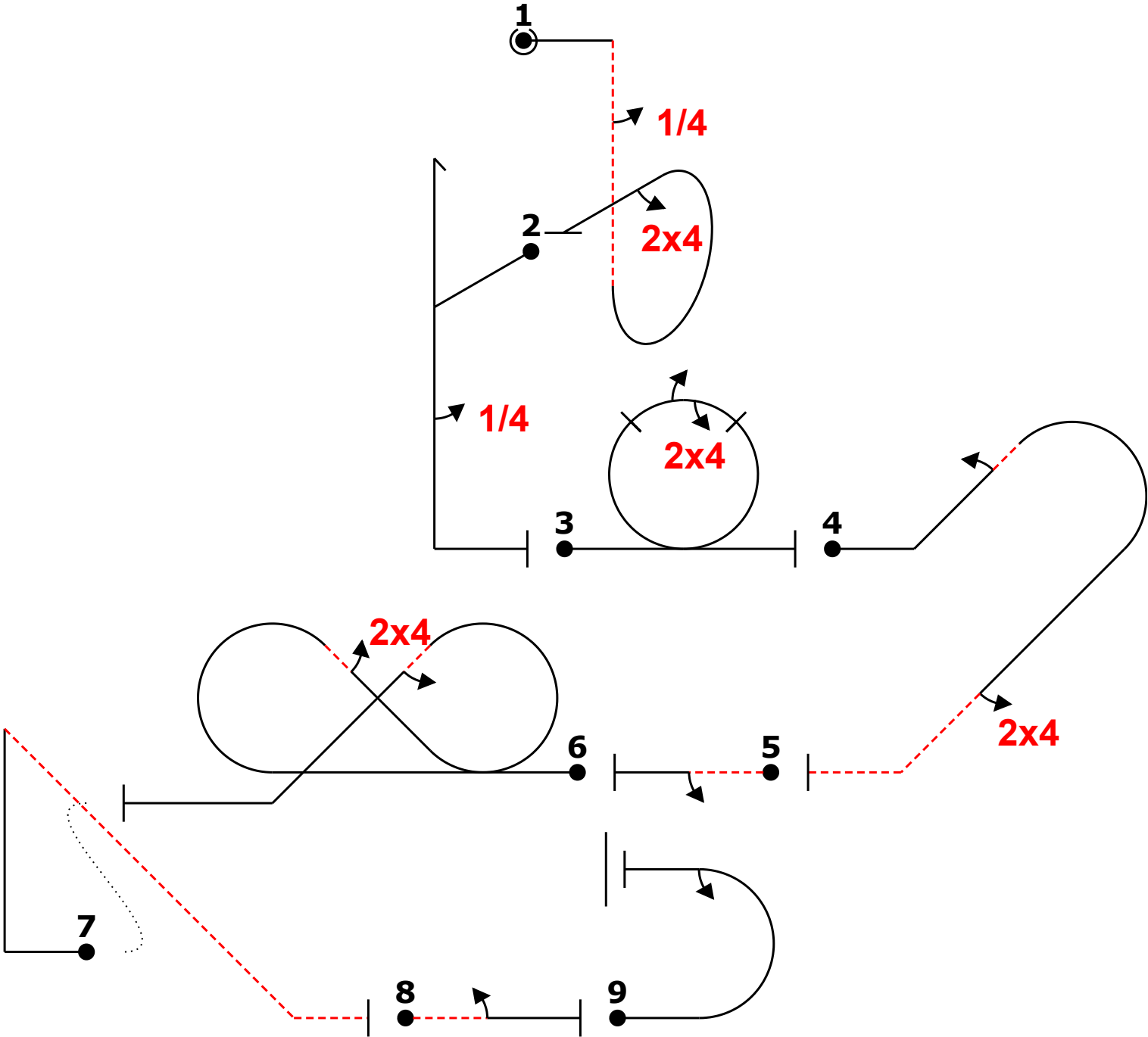
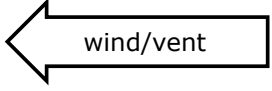

Raul Petrovan Pilot
MDM-1 FOX YR-101c A/C



		Form B
Pilot ID	CIVA Glider Advanced Free	
	Flight #	

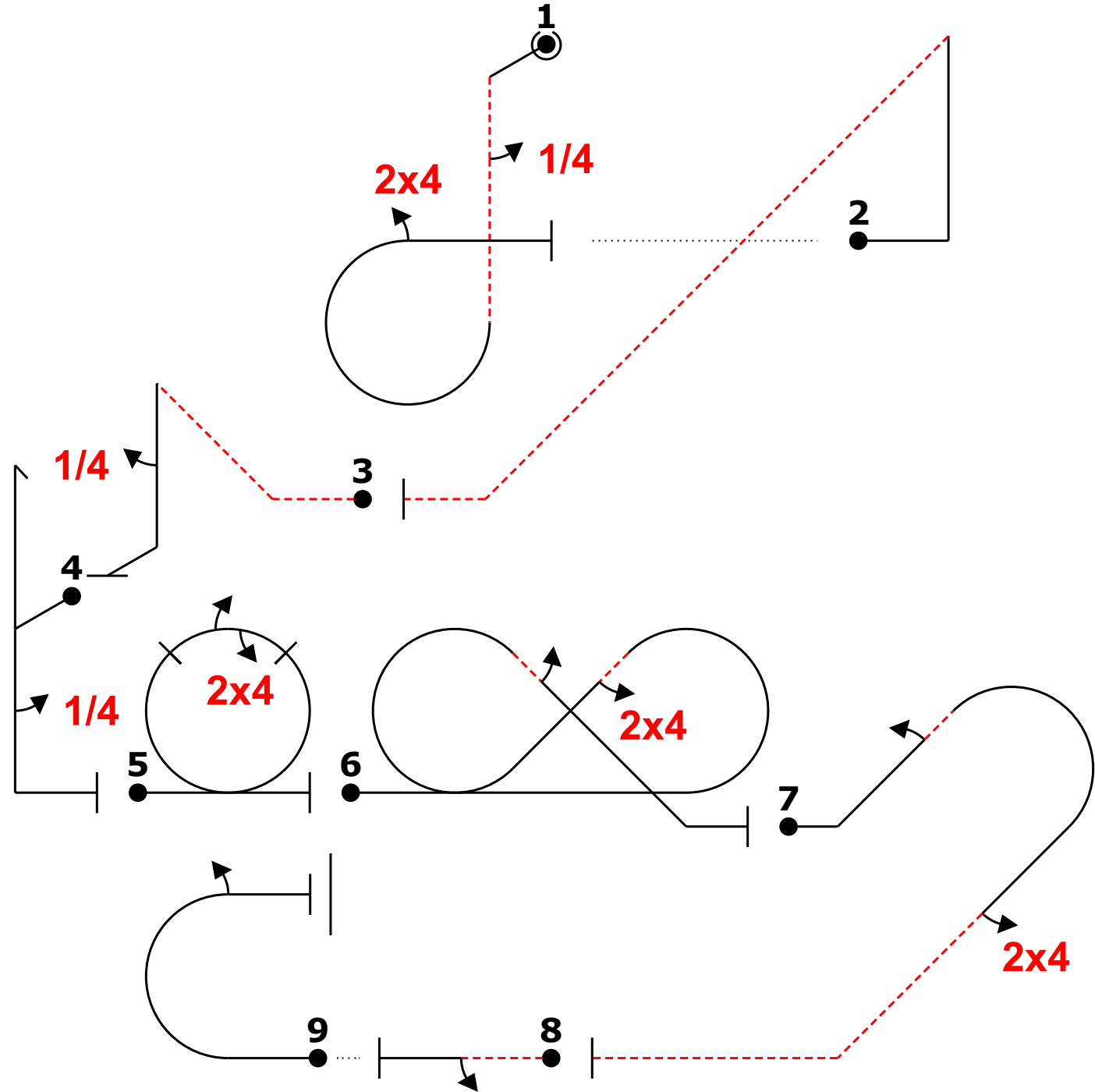
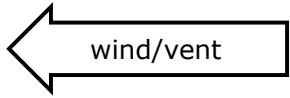

ej "@C" 4irp24~ (11,0) "@E" k.....' - "@L" -t,4 "@F" h4'' "@D" ""+o24,2+"" "@G" cc(24)2+"" "@B" ""+2rdb24...'' - "@L" -2 (1,0) "@A" m2

Miłosz Gondek Pilot
S-1 Swift SP-3532 A/C



WAGAC Oschatz 2024		Form B
Pilot ID	CIVA Glider Advanced Free	Flight #

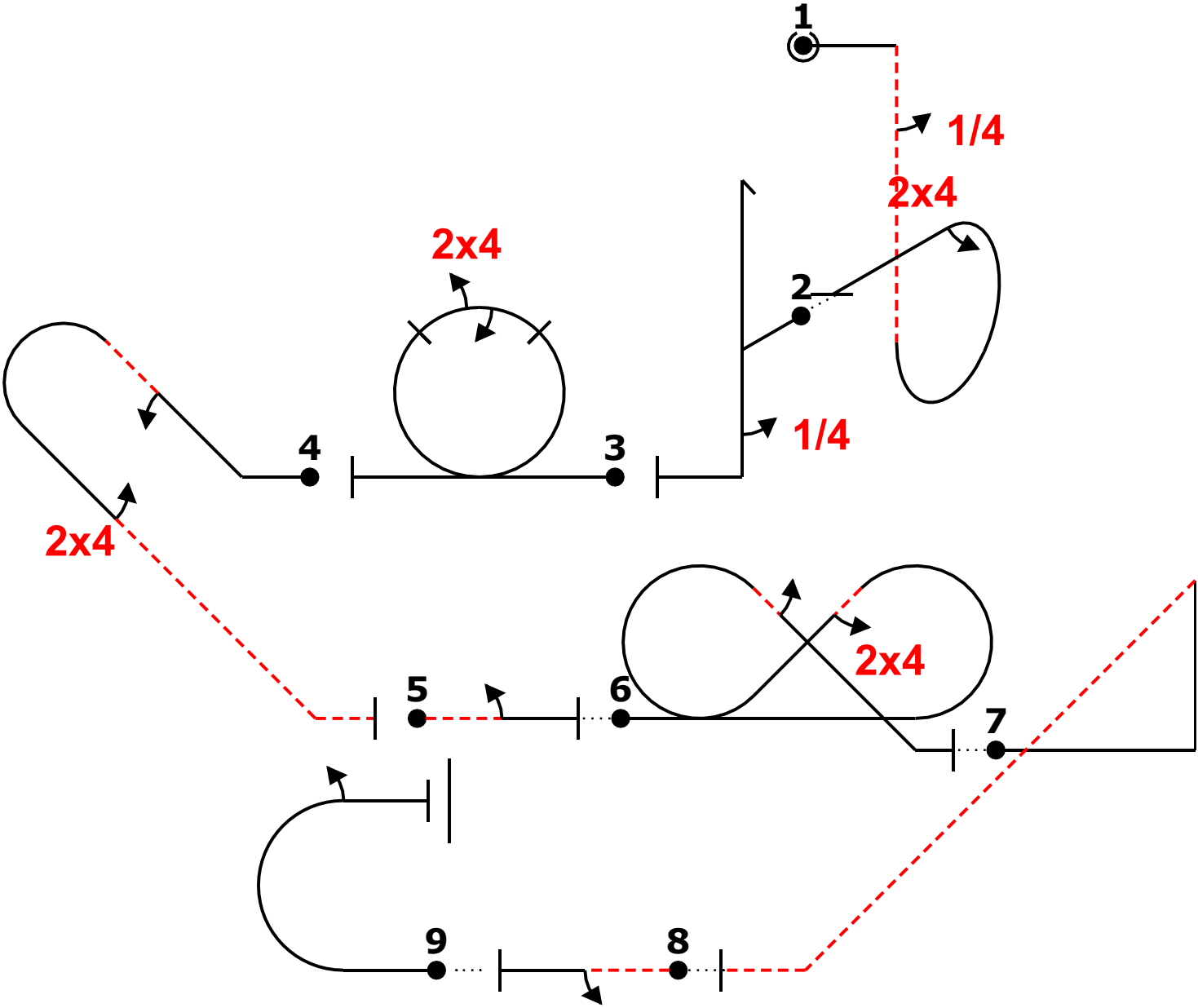
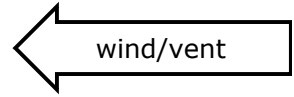

Holger Geusen
Pilot
SZD-59 D-6668
A/C



		Form B
Pilot ID	CIVA Glider Advanced Free	
	Flight #	

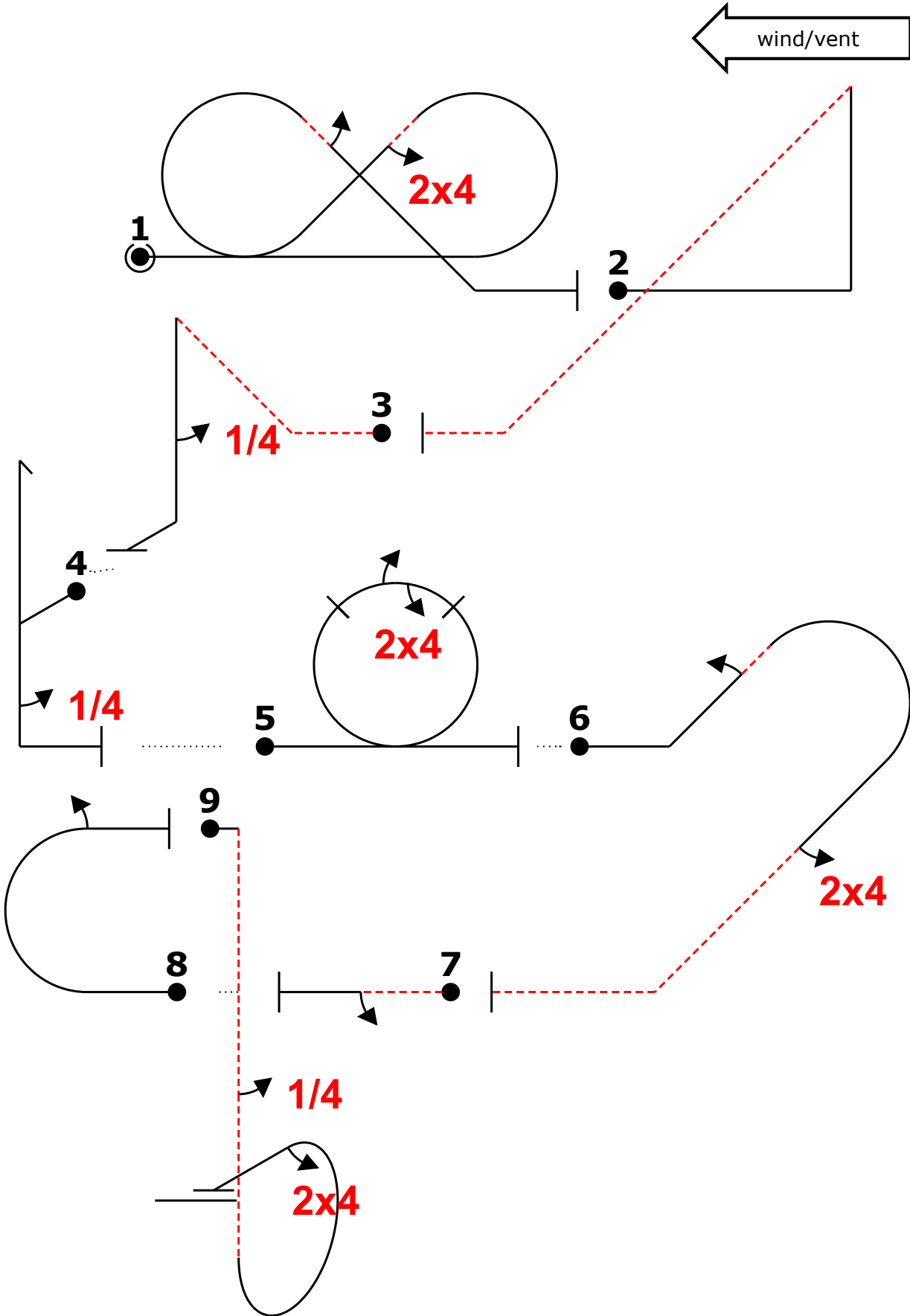

"@G" cc(24)2+"" "@E" ~++k..."- "@L" -t''4 (1,0) "@F" h4 (4,0) "@D" o24,2 (-1,0) "@B" `2rdb24...''-"""" "@L" -2 (-1,0) "@A" m2 "@C" """"+. ..41rp24

Pascal Zollkofer
 Pilot
 SZD-59 HB-3559
 A/C



		Form B
Pilot ID	CIVA Glider Advanced Free	Flight #

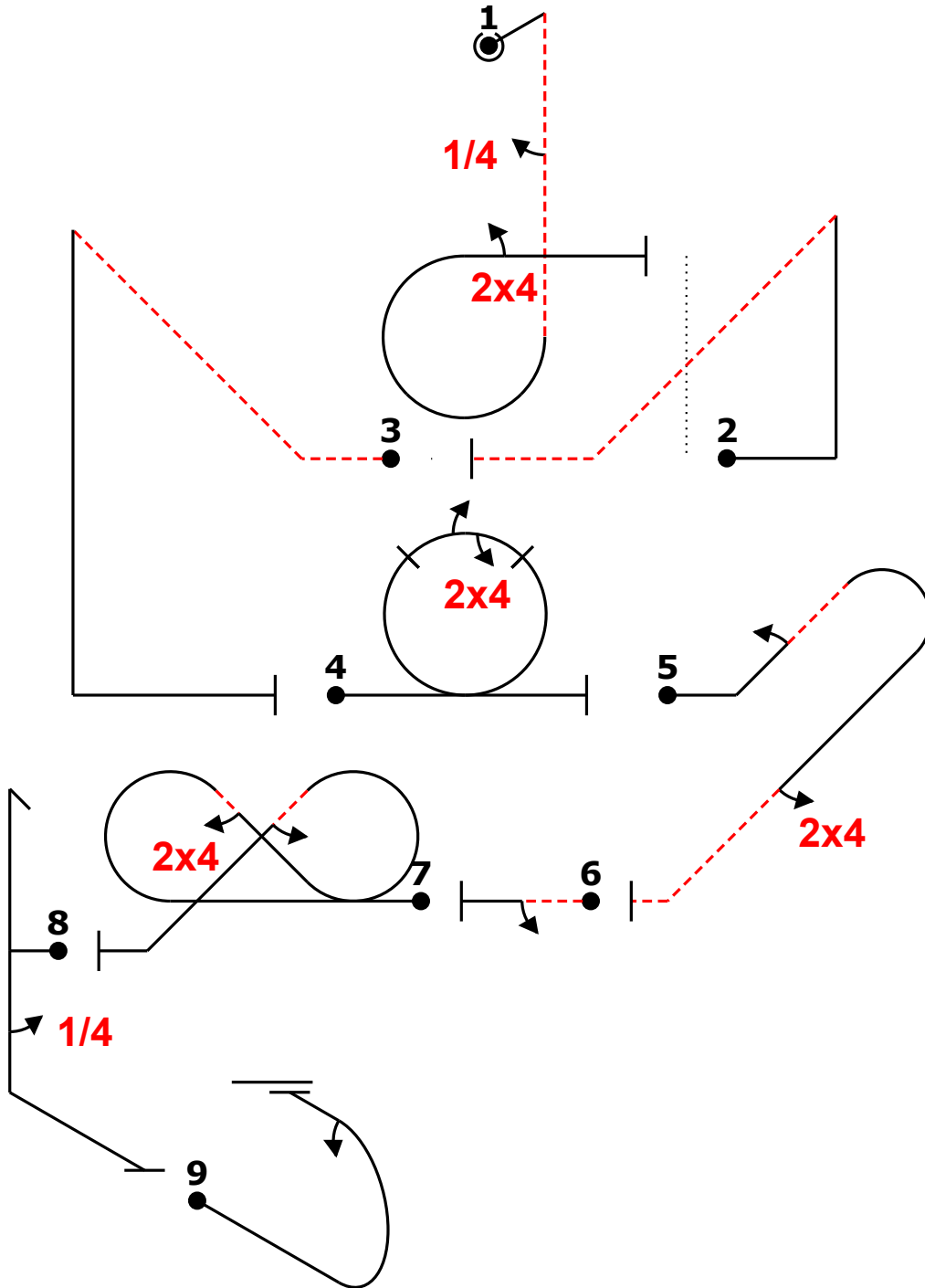
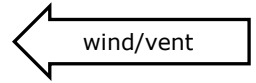

Glider			
Fig	Aresti	K	
1 C	8.6.4.3	13	24
	9.1.5.1	3	
	9.4.3.2	8	
2 E	1.2.5.1	14	14
3 Add.	1.2.2.2	13	5
4 D	7.4.1.1	10	24
	9.4.3.2	8	
	9.1.3.2	6	
5 B	8.4.16.1	14	31
	9.1.2.2	9	
	9.4.4.2	8	
6 Add.	1.1.1.4	2	5
	9.1.3.2	6	
7 G	7.8.4.1	19	33
	9.4.4.2	8	
	9.1.4.2	6	
8 F	5.2.1.1	17	20
	9.1.5.1	3	
9 A	7.2.2.1	6	12
	9.1.3.2	6	
Total K = 168 (max K = 180)			

eja "eC" .,4'irp'|"24- [0,10] "eB" -'k'--- [0,0] "eL" -...t...++ "eD" > o24,2 (0,0) "eB" -4% -2.'rdb...'24...'-----
 ~~~ "eL" -'2' "eG" -2% \cc(,24)'|"2'+~~~~ "eB" /~~+h4'++- "eA" > ...'m2

Zhehao(Jason) Tang Pilot  
 MDM-1 Fox SE-URH A/C



|                          |                           |        |
|--------------------------|---------------------------|--------|
| WAGAC Oschatz 01/08/2024 |                           | Form B |
| Pilote ID                | CIVA Glider Advanced Free | Vol N° |

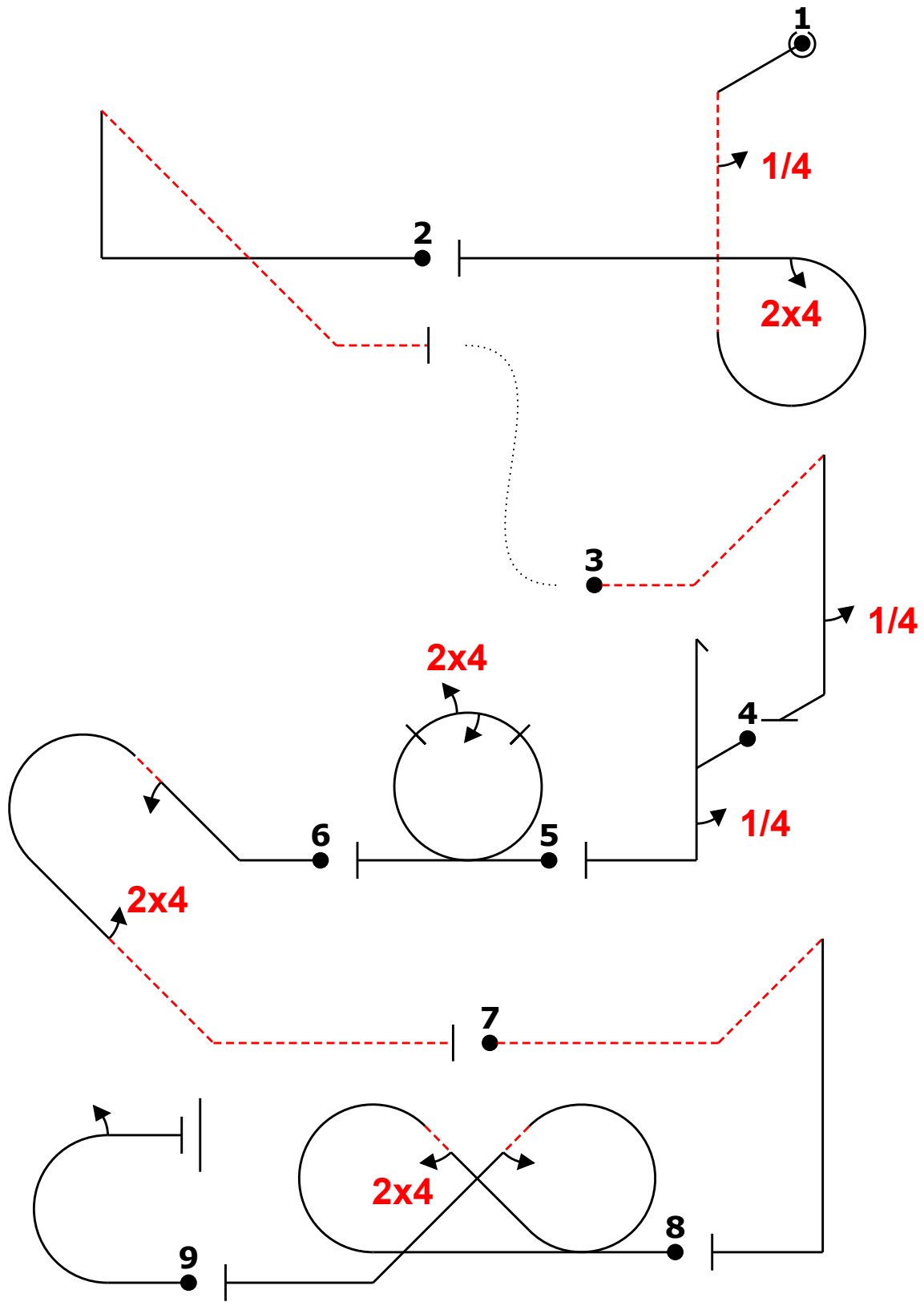

| Planeur                               |          |    |    |
|---------------------------------------|----------|----|----|
| Fig                                   | Aresti   | K  |    |
| 1<br>C                                | 8.6.4.3  | 13 | 24 |
|                                       | 9.1.5.1  | 3  |    |
|                                       | 9.4.3.2  | 8  |    |
| 2<br>E                                | 1.2.5.1  | 14 | 14 |
| 3<br>Add.                             | 1.2.2.2  | 13 | 5  |
|                                       | 9.1.5.1  | 3  |    |
| 4<br>F                                | 5.2.1.1  | 17 | 20 |
|                                       | 9.1.5.1  | 3  |    |
| 5<br>D                                | 7.4.1.1  | 10 | 24 |
|                                       | 9.4.3.2  | 8  |    |
|                                       | 9.1.3.2  | 6  |    |
| 6<br>B                                | 8.4.16.1 | 14 | 31 |
|                                       | 9.1.2.2  | 9  |    |
|                                       | 9.4.4.2  | 8  |    |
| 7<br>Add.                             | 1.2.2.2  | 13 | 5  |
| 8<br>G                                | 7.8.4.1  | 19 | 33 |
|                                       | 9.4.4.2  | 8  |    |
|                                       | 9.1.4.2  | 6  |    |
| 9<br>A                                | 7.2.2.1  | 6  | 12 |
|                                       | 9.1.3.2  | 6  |    |
| <b>Total K = 168</b><br>(max K = 180) |          |    |    |

ej "@C" +4'irp24++++> "@E" ~~~~~`k'~ (5,13) "@L" ~~~'t.'4 "@F" `h`4~~ "@D" ~~~o24,2 "@B" 2rdb24...~ "@L" ~~~~~t...~ "@G" /c c(,24)2 "@A" m2

Céline Rault Pilote  
 Swift S-1 F-CHBA Avion



|                    |                                  |          |
|--------------------|----------------------------------|----------|
| WAGAC Oschatz 2024 |                                  | Form B   |
| Pilot ID           | CIVA Glider Advanced Programme 3 | Flight # |

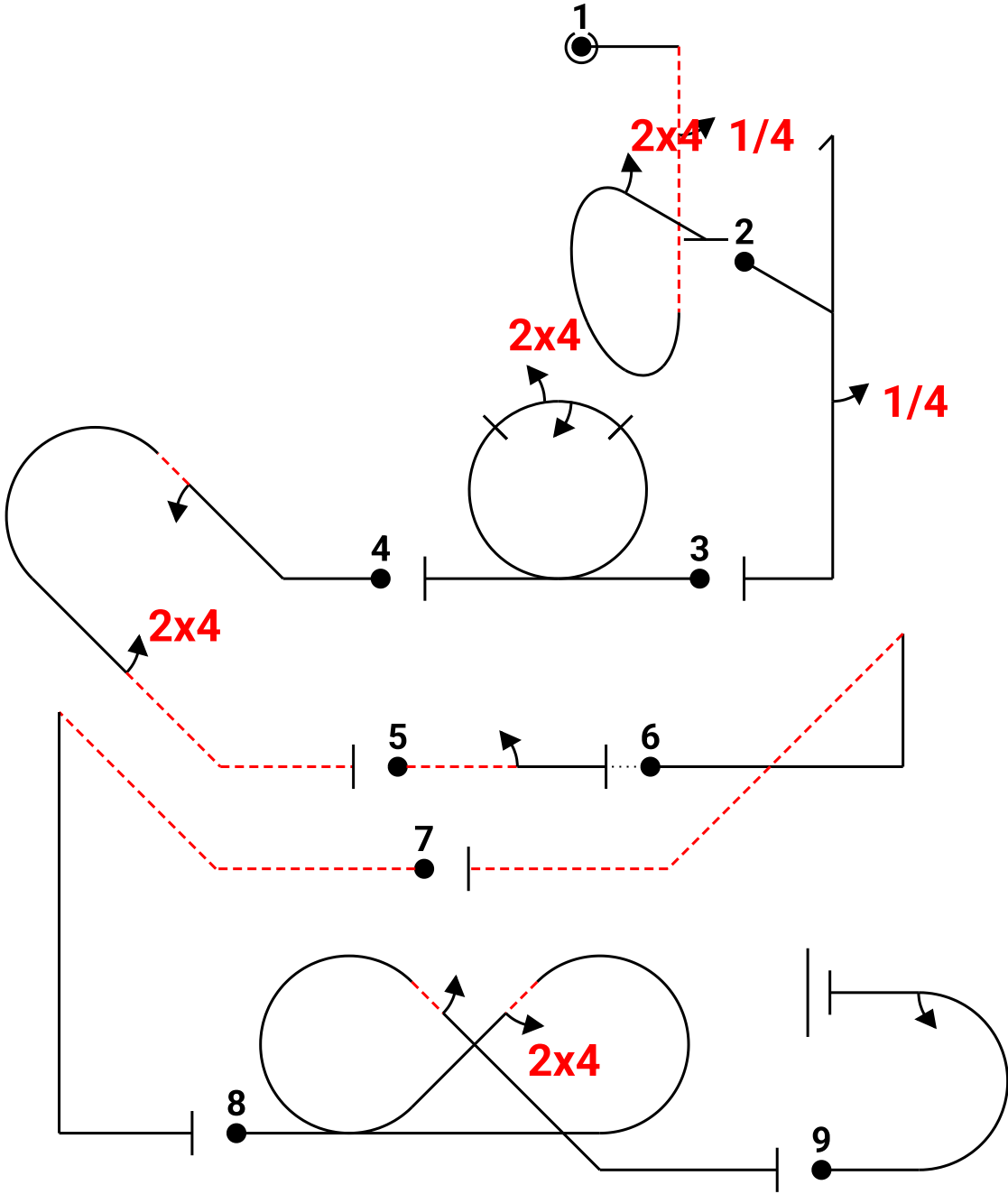
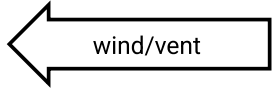

| Glider                                |          |    |    |
|---------------------------------------|----------|----|----|
| Fig                                   | Aresti   | K  |    |
| 1<br>C                                | 8.6.4.3  | 13 | 24 |
|                                       | 9.1.5.1  | 3  |    |
|                                       | 9.4.3.2  | 8  |    |
| 2<br>F                                | 5.2.1.1  | 17 | 20 |
|                                       | 9.1.5.1  | 3  |    |
| 3<br>D                                | 7.4.1.1  | 10 | 24 |
|                                       | 9.4.3.2  | 8  |    |
|                                       | 9.1.3.2  | 6  |    |
| 4<br>B                                | 8.4.16.1 | 14 | 31 |
|                                       | 9.1.2.2  | 9  |    |
|                                       | 9.4.4.2  | 8  |    |
| 5<br>Add.                             | 1.1.1.4  | 2  | 5  |
|                                       | 9.1.3.2  | 6  |    |
| 6<br>E                                | 1.2.5.1  | 14 | 14 |
| 7<br>Add.                             | 1.2.2.2  | 13 | 5  |
|                                       |          |    |    |
| 8<br>G                                | 7.8.4.1  | 19 | 33 |
|                                       | 9.4.4.2  | 8  |    |
|                                       | 9.1.4.2  | 6  |    |
| 9<br>A                                | 7.2.2.1  | 6  | 12 |
|                                       | 9.1.3.2  | 6  |    |
| <b>Total K = 168</b><br>(max K = 180) |          |    |    |

Jelle Heikamp Pilot  
 MDM-1 Fox PH-1091  
 A/C



|          |                                  |        |
|----------|----------------------------------|--------|
|          |                                  | Form B |
| Pilot ID | CIVA Glider Advanced Programme 3 |        |
|          | Flight #                         |        |

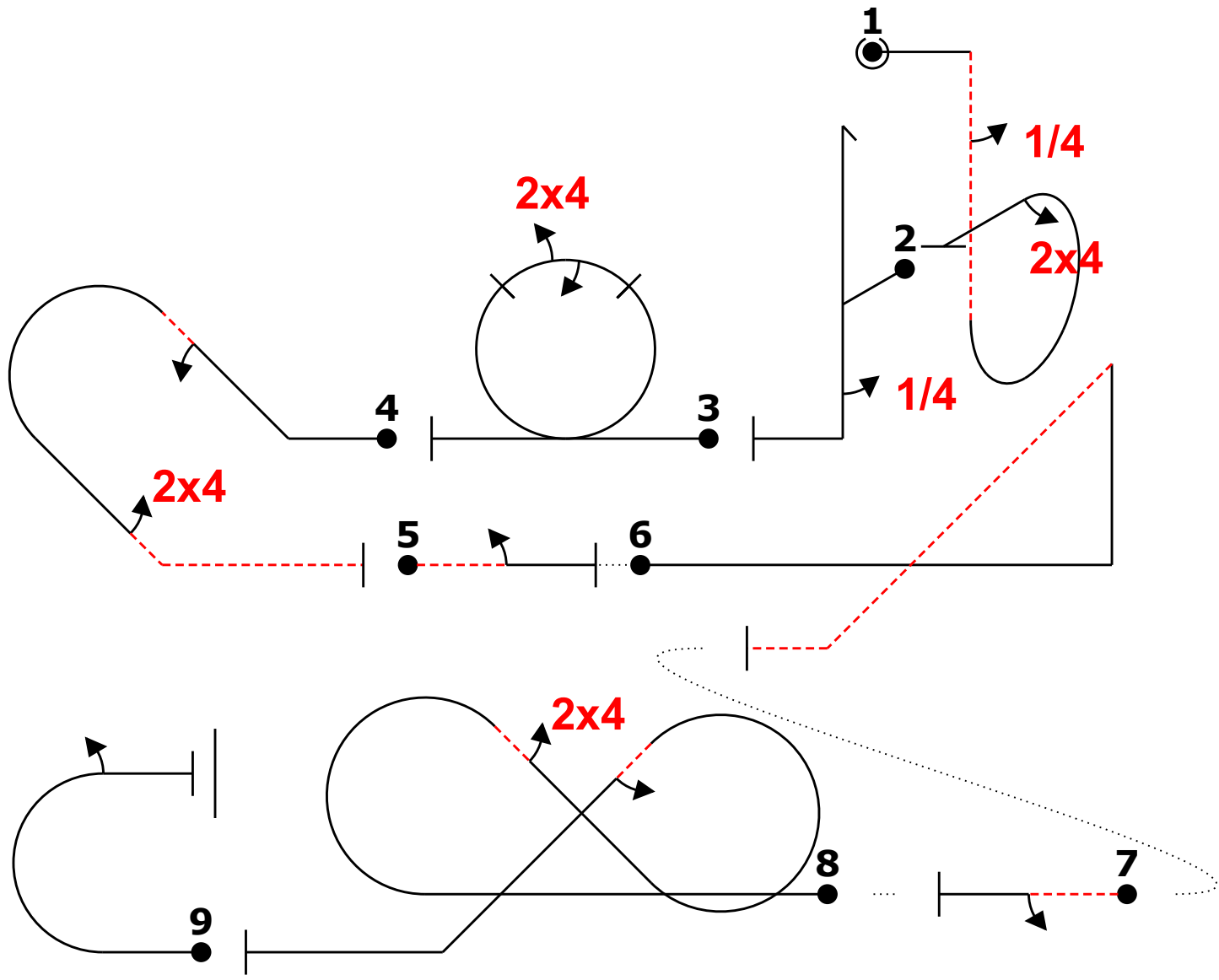
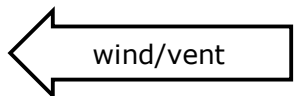

"@C" 4irp24 "@F" h4 "@D" o24,2 "@B" 2rdb24-"" "@L" -2 (-2,0) "@E" -1% ~+++++  
 +k.'- "@L" (21,11) -2 (-1,0) "@G" 1% cc(24')2 "@A" m2

**Christian Syfrig** Pilot  
 MDM-1 HB-3241  
 A/C



|            |                           |        |
|------------|---------------------------|--------|
|            |                           | Form B |
| Piloten ID | CIVA Glider Advanced Free | Flug # |

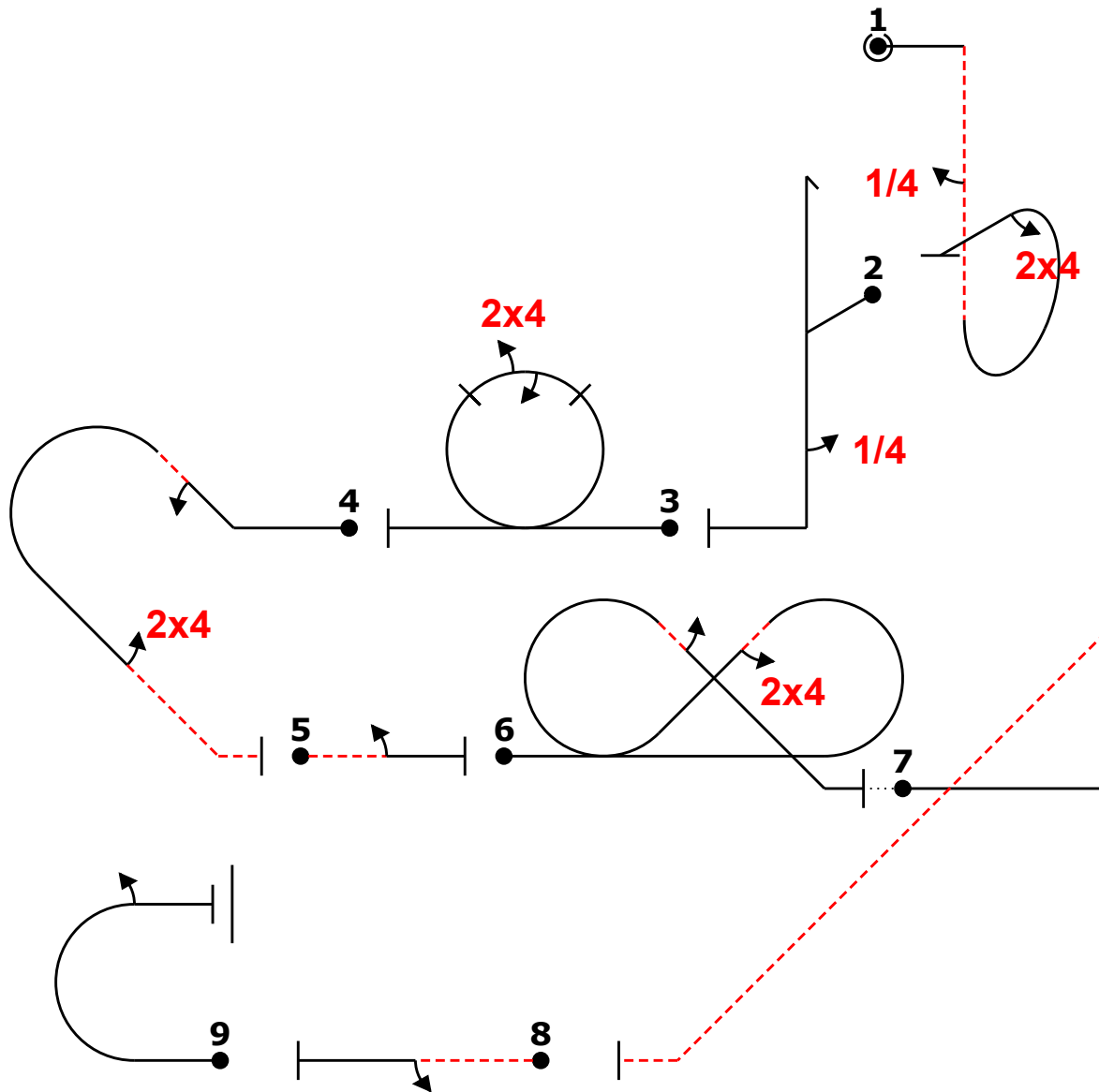
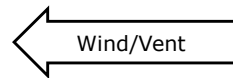

| Segelflug                             |          |    |    |
|---------------------------------------|----------|----|----|
| Fig                                   | Aresti   | K  |    |
| 1<br>C                                | 8.6.4.3  | 13 | 24 |
|                                       | 9.1.5.1  | 3  |    |
|                                       | 9.4.3.2  | 8  |    |
| 2<br>F                                | 5.2.1.1  | 17 | 20 |
|                                       | 9.1.5.1  | 3  |    |
| 3<br>D                                | 7.4.1.1  | 10 | 24 |
|                                       | 9.4.3.2  | 8  |    |
|                                       | 9.1.3.2  | 6  |    |
| 4<br>B                                | 8.4.16.1 | 14 | 31 |
|                                       | 9.1.2.2  | 9  |    |
|                                       | 9.4.4.2  | 8  |    |
| 5<br>Add.                             | 1.1.1.4  | 2  | 5  |
|                                       | 9.1.3.2  | 6  |    |
| 6<br>G                                | 7.8.4.1  | 19 | 33 |
|                                       | 9.4.4.2  | 8  |    |
|                                       | 9.1.4.2  | 6  |    |
| 7<br>E                                | 1.2.5.1  | 14 | 14 |
| 8<br>Add.                             | 1.1.1.4  | 2  | 5  |
|                                       | 9.1.3.2  | 6  |    |
| 9<br>A                                | 7.2.2.1  | 6  | 12 |
|                                       | 9.1.3.2  | 6  |    |
| <b>Total K = 168</b><br>(max K = 180) |          |    |    |

"@C" .,4`irp24 (0,0) "@F" ~h'4'~ "@D" ~o24,2~ "@B" 1% ~`2rdb24.'-~ "@L" -2 "@G" cc(24)2+~ (-2,0) "@E" +  
+`k..... (0,0) "@L" ~-2~ (0,0) "@A" m2

Richard Münzberger  
Pilot  
SZD-59 SP-3886  
Flugzeug



|                               |                                  |        |
|-------------------------------|----------------------------------|--------|
| WAGAC 2024 Oschatz 02/08/2024 |                                  | Form B |
| Pilote ID                     | CIVA Glider Advanced Programme 3 | Vol N° |

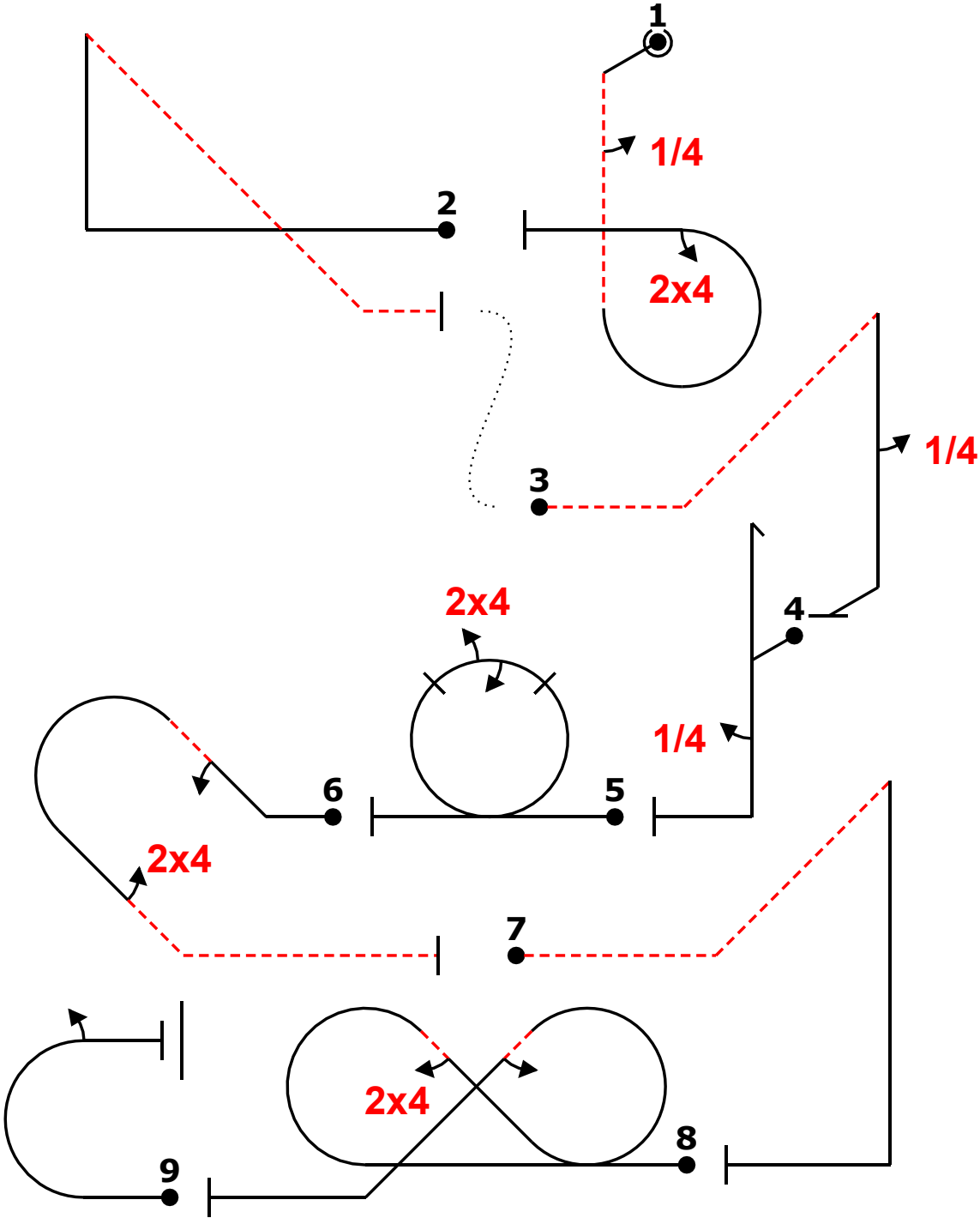

| Planeur                               |          |    |    |
|---------------------------------------|----------|----|----|
| Fig                                   | Aresti   | K  |    |
| 1<br>C                                | 8.6.4.3  | 13 | 24 |
|                                       | 9.1.5.1  | 3  |    |
|                                       | 9.4.3.2  | 8  |    |
| 2<br>E                                | 1.2.5.1  | 14 | 14 |
| 3<br>Add.                             | 1.2.2.2  | 13 | 5  |
|                                       | 9.1.5.1  | 3  |    |
| 4<br>F                                | 5.2.1.1  | 17 | 20 |
|                                       | 9.1.5.1  | 3  |    |
| 5<br>D                                | 7.4.1.1  | 10 | 24 |
|                                       | 9.4.3.2  | 8  |    |
|                                       | 9.1.3.2  | 6  |    |
| 6<br>B                                | 8.4.16.1 | 14 | 31 |
|                                       | 9.1.2.2  | 9  |    |
|                                       | 9.4.4.2  | 8  |    |
| 7<br>Add.                             | 1.2.2.2  | 13 | 5  |
| 8<br>G                                | 7.8.4.1  | 19 | 33 |
|                                       | 9.4.4.2  | 8  |    |
|                                       | 9.1.4.2  | 6  |    |
| 9<br>A                                | 7.2.2.1  | 6  | 12 |
|                                       | 9.1.3.2  | 6  |    |
| <b>Total K = 168</b><br>(max K = 180) |          |    |    |

Frédéric Durand  
Pilote  
Swift S-1 F-CHBA  
Avion



|          |                           |          |
|----------|---------------------------|----------|
|          |                           | Form B   |
| Pilot ID | CIVA Glider Advanced Free | Flight # |

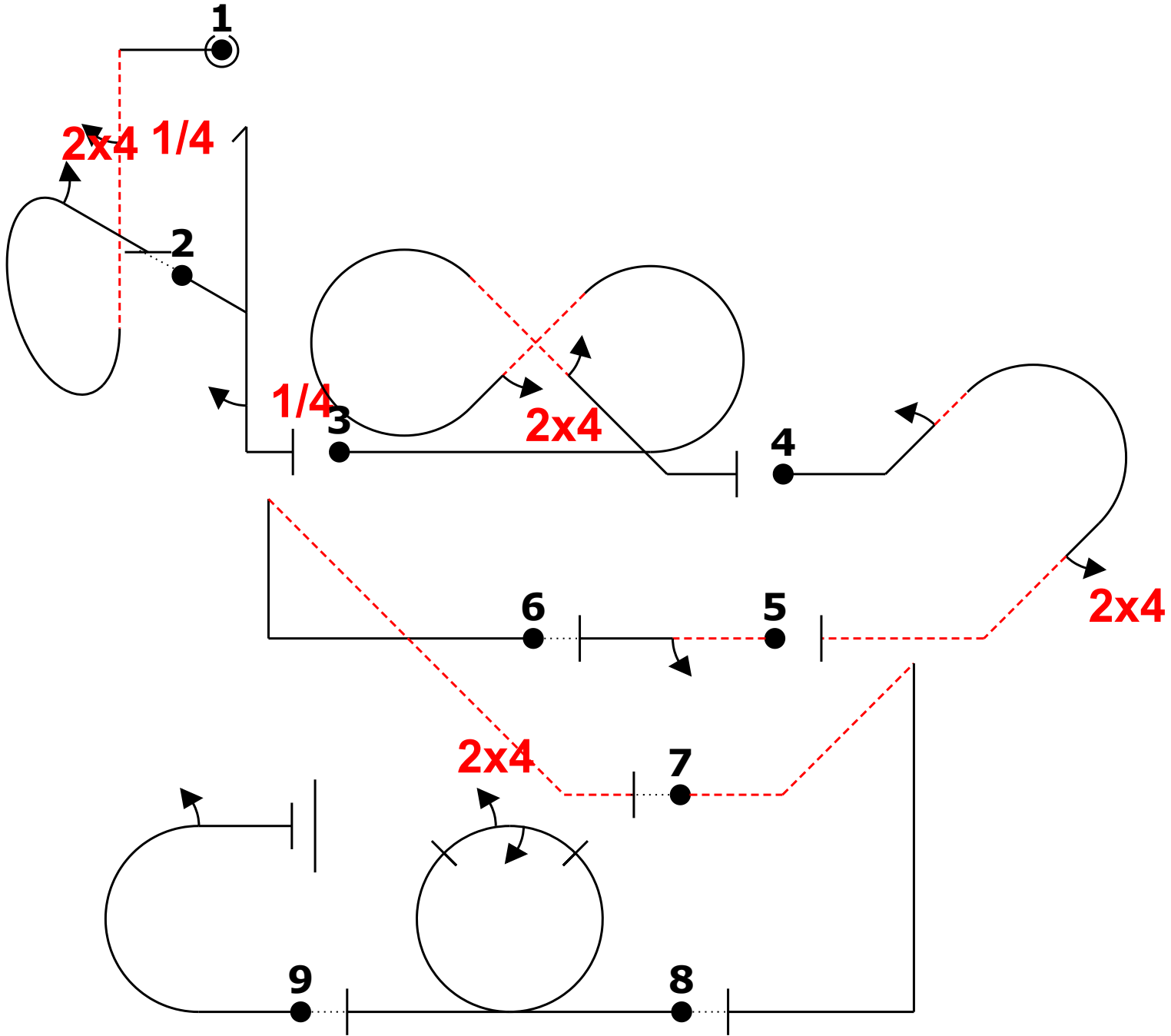

ed "@C" /,"|"4irp24 (-2,-1) "@F" h,"|"4+~ "@G" ~~~cc(-.24~). '2~+~ "@B" ~~~2rdb~"24.-~ "@L" -2 (2,0) "@E" ~++~k'-' (-2,0) "@L" -t..'+'~ (2,0) "@0" ~o24,2~ (2,0) "@A" m2

Tobias Ohlig Pilot  
 Swift S-1 D-3735 A/C





|                                  |  |          |
|----------------------------------|--|----------|
| Pilot ID                         |  | Form B   |
| CIVA Glider Advanced Programme 3 |  | Flight # |

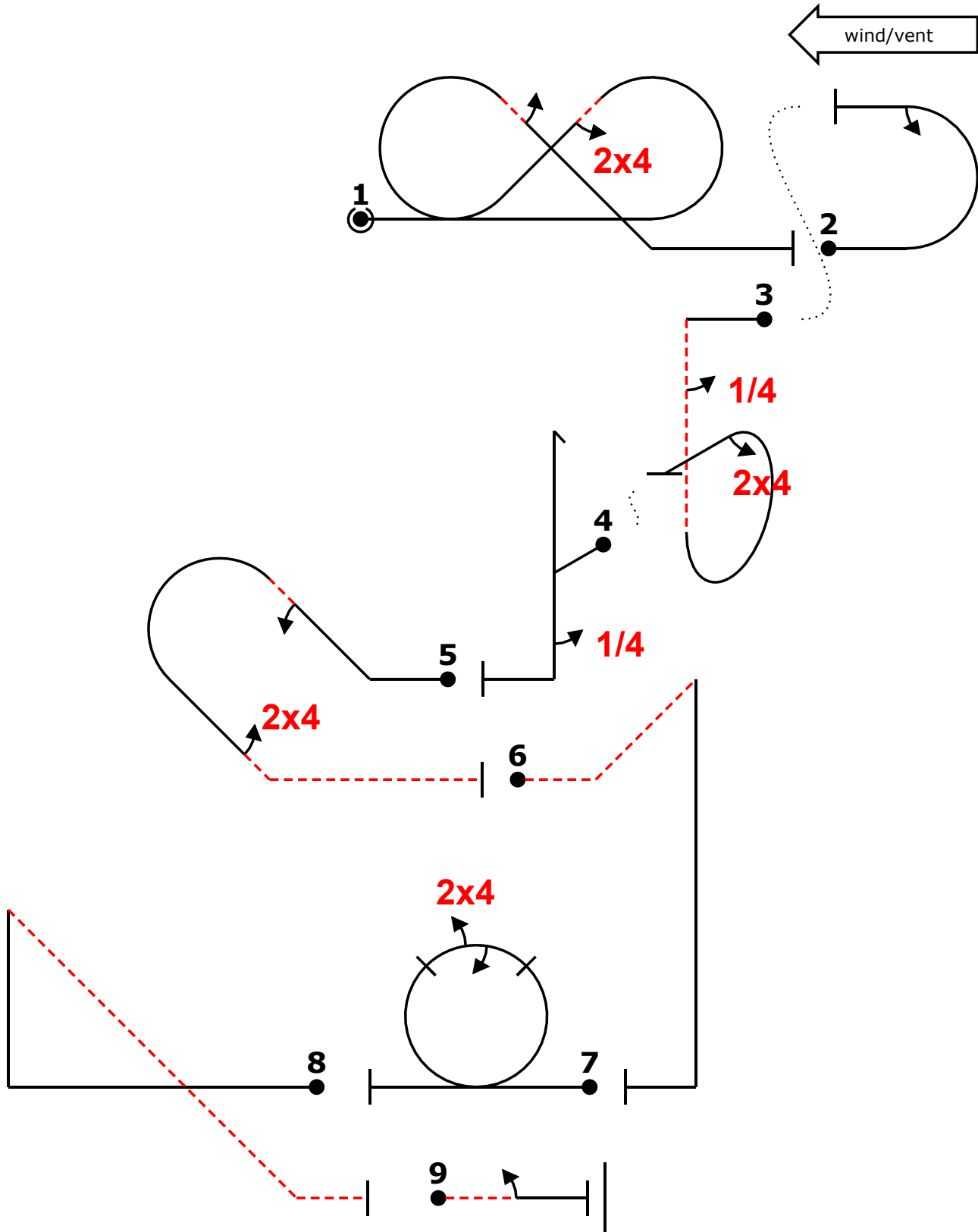

Lea Mollenhauer Pilot  
 Swift D-9590 A/C



|          |                           |        |
|----------|---------------------------|--------|
|          |                           | Form B |
| Pilot ID | CIVA Glider Advanced Free |        |
|          | Flight #                  |        |

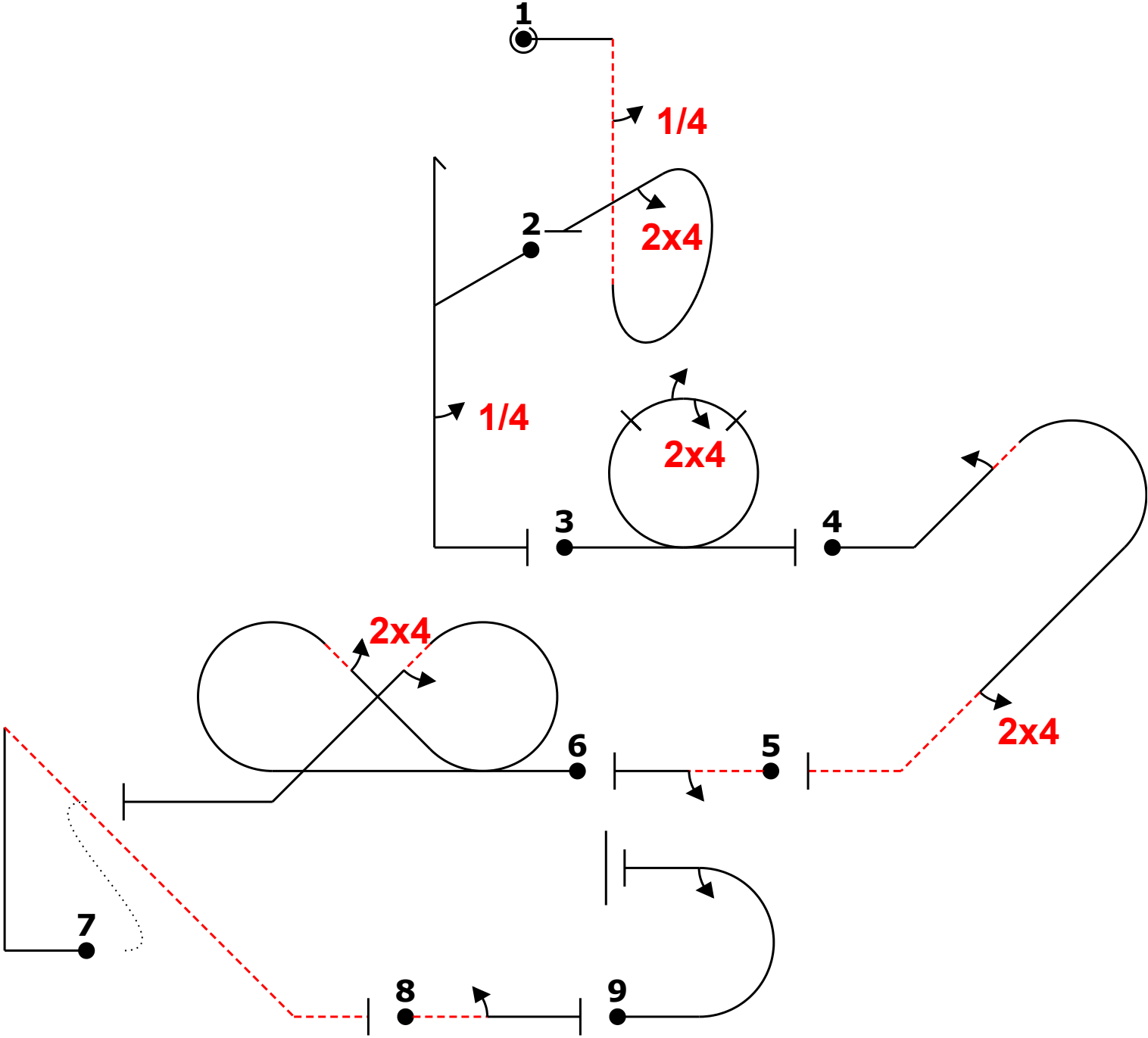
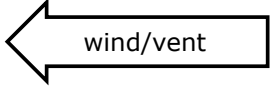

Zsolt Gal Pilot  
MDM-1 FOX YR-101c A/C



|                      |                                  |          |
|----------------------|----------------------------------|----------|
| WAGAC / Oschatz 2024 |                                  | Form B   |
| Pilot ID             | CIVA Glider Advanced Programme 3 | Flight # |

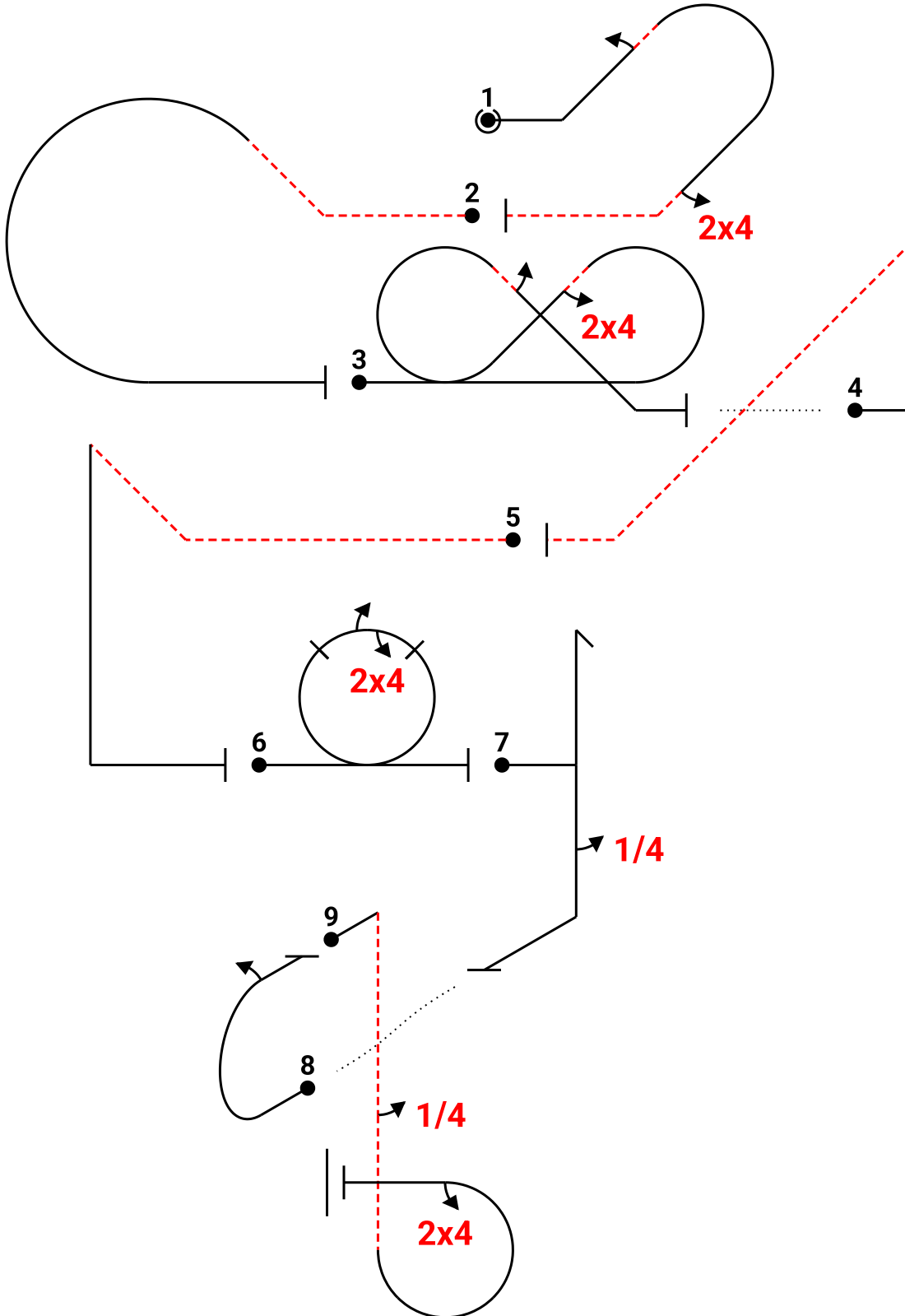
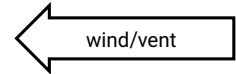

| Glider                                |          |    |    |
|---------------------------------------|----------|----|----|
| Fig                                   | Aresti   | K  |    |
| 1<br>B                                | 8.4.16.1 | 14 | 31 |
|                                       | 9.1.2.2  | 9  |    |
|                                       | 9.4.4.2  | 8  |    |
| 2<br>Add.                             | 8.5.1.2  | 10 | 5  |
| 3<br>G                                | 7.8.4.1  | 19 | 33 |
|                                       | 9.4.4.2  | 8  |    |
|                                       | 9.1.4.2  | 6  |    |
| 4<br>E                                | 1.2.5.1  | 14 | 14 |
| 5<br>Add.                             | 1.2.2.2  | 13 | 5  |
| 6<br>D                                | 7.4.1.1  | 10 | 24 |
|                                       | 9.4.3.2  | 8  |    |
|                                       | 9.1.3.2  | 6  |    |
| 7<br>F                                | 5.2.1.1  | 17 | 20 |
|                                       | 9.1.5.1  | 3  |    |
| 8<br>A                                | 7.2.2.1  | 6  | 12 |
|                                       | 9.1.3.2  | 6  |    |
| 9<br>C                                | 8.6.4.3  | 13 | 24 |
|                                       | 9.1.5.1  | 3  |    |
|                                       | 9.4.3.2  | 8  |    |
| <b>Total K = 168</b><br>(max K = 180) |          |    |    |

"@B" 2rdb24. "" "@L" 11% .....rc+..... "@G" cc(24)2+..... (6,0) "@E" `+k.... "@L" .....t...'+~ "@D" o24,2 "@F" h'4''  
 +-- (-7,5) "@A" m2 "@C" ...'4irp24

Michal ČERVENÝ Pilot  
 MDM1 FOX OK-4000 A/C